

Industrial Automation Headquarters

Taiwan: Delta Electronics, Inc.
Taoyuan Technology Center
No.18, Xinglong Rd., Taoyuan District,
Taoyuan City 33068, Taiwan
TEL: +886-3-362-6301 / FAX: +886-3-371-6301

Asia

China: Delta Electronics (Shanghai) Co., Ltd.
No.182 Minyu Rd., Pudong Shanghai, P.R.C.
Post code : 201209
TEL: +86-21-6872-3988 / FAX: +86-21-6872-3996
Customer Service: 400-820-9595

Japan: Delta Electronics (Japan), Inc.
Industrial Automation Sales Department
2-1-14 Shibadaimon, Minato-ku
Tokyo, Japan 105-0012
TEL: +81-3-5733-1155 / FAX: +81-3-5733-1255

Korea: Delta Electronics (Korea), Inc.
1511, 219, Gasan Digital 1-Ro., Geumcheon-gu,
Seoul, 08501 South Korea
TEL: +82-2-515-5305 / FAX: +82-2-515-5302

Singapore: Delta Energy Systems (Singapore) Pte Ltd.
4 Kaki Bukit Avenue 1, #05-04, Singapore 417939
TEL: +65-6747-5155 / FAX: +65-6744-9228

India: Delta Electronics (India) Pvt. Ltd.
Plot No.43, Sector 35, HSIIDC Gurgaon,
PIN 122001, Haryana, India
TEL: +91-124-4874900 / FAX: +91-124-4874945

Thailand: Delta Electronics (Thailand) PCL.
909 Soi 9, Moo 4, Bangpoo Industrial Estate (E.P.Z),
Pattana 1 Rd., T.Phraksa, A.Muang,
Samutprakarn 10280, Thailand
TEL: +66-2709-2800 / FAX: +66-2709-2827

Australia: Delta Electronics (Australia) Pty Ltd.
Unit 20-21/45 Normanby Rd., Notting Hill Vic 3168, Australia
TEL: +61-3-9543-3720

Americas

USA: Delta Electronics (Americas) Ltd.
5101 Davis Drive, Research Triangle Park, NC 27709, U.S.A.
TEL: +1-919-767-3813 / FAX: +1-919-767-3969

Brazil: Delta Electronics Brazil
Rua Itapeva, 26 - 3º, andar Edifício Itapeva,
One - Bela Vista 01332-000 - São Paulo - SP - Brazil
TEL: +55-12-3932-2300 / FAX: +55-12-3932-237

Mexico: Delta Electronics International Mexico S.A. de C.V.
Gustavo Baz No. 309 Edificio E PB 103
Colonia La Loma, CP 54060
Tlalnepantla, Estado de México
TEL: +52-55-3603-9200

EMEA

EMEA Headquarters: Delta Electronics (Netherlands) B.V.
Sales: Sales.IA.EMEA@deltaww.com
Marketing: Marketing.IA.EMEA@deltaww.com
Technical Support: iatechnicalsupport@deltaww.com
Customer Support: Customer-Support@deltaww.com
Service: Service.IA.emea@deltaww.com
TEL: +31(0)40 800 3900

BENELUX: Delta Electronics (Netherlands) B.V.
Automotive Campus 260, 5708 JZ Helmond, The Netherlands
Mail: Sales.IA.Benelux@deltaww.com
TEL: +31(0)40 800 3900

DACH: Delta Electronics (Netherlands) B.V.
Coesterweg 45, D-59494 Soest, Germany
Mail: Sales.IA.DACH@deltaww.com
TEL: +49(0)2921 987 0

France: Delta Electronics (France) S.A.
ZI du bois Challand 2, 15 rue des Pyrénées,
Lisses, 91090 Evry Cedex, France
Mail: Sales.IA.FR@deltaww.com
TEL: +33(0)1 69 77 82 60

Iberia: Delta Electronics Solutions (Spain) S.L.U
Ctra. De Villaverde a Vallecas, 265 1º Dcha Ed.
Hormigueras – P.I. de Vallecas 28031 Madrid
TEL: +34(0)91 223 74 20
Carrer Llacuna 166, 08018 Barcelona, Spain
Mail: Sales.IA.Iberia@deltaww.com

Italy: Delta Electronics (Italy) S.r.l.
Via Meda 2-22060 Novedrate(CO)
Piazza Grazioli 18 00186 Roma Italy
Mail: Sales.IA.Italy@deltaww.com
TEL: +39 039 8900365

Russia: Delta Energy System LLC
Vereyskaya Plaza II, office 112 Vereyskaya str.
17 121357 Moscow Russia
Mail: Sales.IA.RU@deltaww.com
TEL: +7 495 644 3240

Turkey: Delta Greentech Elektronik San. Ltd. Sti. (Turkey)
Şerifali Mah. Hendem Cad. Kule Sok. No:16-A
34775 Ümraniye – İstanbul
Mail: Sales.IA.Turkey@deltaww.com
TEL: + 90 216 499 9910

MEA: Eltek Dubai (Eltek MEA DMCC)
OFFICE 2504, 25th Floor, Saba Tower 1,
Jumeirah Lakes Towers, Dubai, UAE
Mail: Sales.IA.MEA@deltaww.com
TEL: +971(0)4 2690148

Delta Hybrid Energy Saving System HES-C Series User Manual



Delta Hybrid Energy Saving System HES-C Series User Manual



www.deltaww.com

Copyright notice

©Delta Electronics, Inc. All rights reserved.

All information contained in this user manual is the exclusive property of Delta Electronics Inc.

(hereinafter referred to as "Delta ") and is protected by copyright law and all other laws. Delta retains the exclusive rights of this user manual in accordance with the copyright law and all other laws. No parts in this manual may be reproduced, transmitted, transcribed, translated or used in any other ways without the prior consent of Delta.

Limitation of Liability

The contents of this user manual are only for the use of the products manufactured by Delta. Except as defined in special mandatory laws, Delta provides this user manual "as is" and does not offer any kind of warranty through this user manual for using the product, either express or implied, including but not limited to the following: (i) this product will meet your needs or expectations; (ii) the information contained in the product is current and correct; (iii) the product does not infringe any rights of any other person. You shall bear your own risk to use this product.

In no event shall Delta, its subsidiaries, affiliates, managers, employees, agents, partners and licensors be liable for any direct, indirect, incidental, special, derivative or consequential damages (including but not limited to the damages for loss of profits, goodwill, use or other intangible losses) unless the laws contains special mandatory provisions to the contrary.

Delta reserves the right to make changes to the user manual and the products described in the user manual without prior notice and afterwards.

Preface

Thank you for choosing the Hybrid Energy System (HES) designed exclusively for the Delta Injection Machine, which consists of Hybrid Servo Controller (VFD-VJ) series and servo oil pump.

These production instructions provide the users with complete information regarding the installation, parameter configuration, anomaly diagnosis, troubleshooting, and routine maintenance of the Hybrid Servo Driver. To ensure correct installation and operation of the hybrid servo driver, please read the instructions carefully before installing the machine. In addition, please store the enclosed CD-ROM properly and pass down to the machine users.

The Hybrid servo driver is a delicate power electronics product. For the safety of the operators and the security of the machine, please only allow professional electrical engineers to conduct installation, tests, and adjust machine parameters. Please carefully read the contents of the instructions that are marked with "Danger" and "caution". Please contact your local Delta agents for any questions and our professional team will be happy to assist you.

PLEASE READ PRIOR TO INSTALLATION FOR SAFETY.



- Make sure to turn off the power before starting wiring.
- Once the AC power is turned off, when the POWER indicator of the Hybrid Servo Controller is still on, it means there is still high voltage inside the Hybrid Servo Controller, which is very dangerous and do not touch the internal circuits and components. To conduct the maintenance safely, please make sure the voltage between +1 and - is lower than 25Vdc using the handheld multimeter before starting the operation.
- The internal circuit board of Hybrid Servo Controller houses CMOS IC, which is vulnerable to electrostatics. Please do not touch the circuit board by and without any anti-electrostatics measures.
- Never modify the components or wiring inside the Hybrid Servo Controller.
- The E \oplus terminal of Hybrid Servo Controller must be grounded correctly. The 230V series uses the third type of ground scheme while the 460V series uses special ground.
- This series of products cannot be operated in environments that endanger human safety.
- Please keep children or strangers from approaching Hybrid Servo Controller.



- Never connect AC power to the output terminals U/T1, V/T2, and W/T3 of Hybrid Servo Controller.
 - Please do not conduct stress test on the internal components of Hybrid Servo Controller, for the semiconductor devices therein may be damaged by high-voltage breakdown.
 - Even when the servo oil pump is off, the main loop terminal of Hybrid Servo Controller can still be loaded with high voltage that can be seriously dangerous.
 - Only qualified professional electrical engineers can conduct tasks of installation, wiring, and maintenance of Hybrid Servo Controller °
 - When Hybrid Servo Controller uses external terminals as its run command sources, the
-

	servo oil pump may start running immediately after the power is connected, which may be dangerous with any personnel present.
 CAUTION	<ul style="list-style-type: none">☑ Please choose a safe area to install Hybrid Energy System, where there is no high temperature, direct sunlight, moisture, and water dripping and splash.☑ Please follow the instructions when installing Hybrid Energy System. Any unapproved operation environment may lead to fire, gas explosion, and electroshock.☑ When the wiring between the hybrid controller and the hybrid servo motor is too long, it may compromise the interlayer insulation of the motor. Please install a reactor between them (please refer to Appendix A) to avoid burning of the hybrid servo motor from damaged insulation.☑ The voltage rating of the power supply of Hybrid Servo Controller 230 series cannot be higher than 240V (no higher than 480V for 460 series) and the associated current cannot exceed 5000A RMS (no higher than 10000A RMS for models with 40HP (30kW))

 **NOTE**

- To provide detailed product descriptions, the illustrations are made with the exterior cover or safety shield removed. When the product is running, please make sure the exterior cover is secured and the wiring is correct to ensure safety by following the instructions of the manual.
- The figures in the manual are made for illustration purposes and will be slightly different from the actual products. However, the discrepancy will not affect the interests of clients.
- Since our products are being constantly improved, for information about any changes in specifications, please contact our local agents or visit http://www.deltaww.com/iadownload_acmotordrive to download the most recent versions.

Table of Contents

Chapter 1 Use and Installation

1-1 Product Appearance.....	1-2
1-2 Specifications	1-5
1-3 Introduction of Hybrid Energy System	1-7
1-4 Installation	1-8
1-5 Product Packaging and Dimensions	1-13

Chapter 2 Wiring

2-1 Wiring	2-5
2-2 Description of Main Circuit Terminals.....	2-9
2-3 Description of Control Circuit Terminals.....	2-12
2-4 Wiring of Servo Oil Pump.....	2-17

Chapter 3 Machine Adjustment Procedure

3-1 Description of Control Panel	3-2
3-2 Adjustment Flow Chart.....	3-7
3-3 Machine Adjustment Procedure	3-8
3-4 Confluence Machine Tuning Procedure.....	3-12
3-5 Confluence / Diversion Mode Adjustment Procedure	3-13

Chapter 4 Parameter Functions

4-1 Summary of Parameter Settings	4-2
4-2 Description of Parameter Settings	4-16

Chapter 5 Methods of Anomaly Diagnosis

5-1 Unusual Signal	5-2
5-2 Dynamic fault processing and troubleshooting	5-9
5-3 Resolution for electromagnetic noise and induction noise.....	5-2
5-4 Environment and facilities for installation	5-53

Chapter 6 Maintenance

6-1 Maintenance and Inspection	6-2
6-2 Greasy Dirt Problem	6-6
6-3 Fiber Dust Problem	6-7
6-4 Erosion Problem	6-8
6-5 Industrial Dust Problem	6-9
6-6 Wiring and Installation Problem.....	6-12
6-7 Multi-function Input/ Output Terminals Problem	6-13
6-8 Maintenance of Coupling.....	6-14

Appendix A Optional Accessories

A-1 Non-fuse Circuit Breaker.....	A-2
A2 Reactor.....	A-3
A-3 Digital Keypad KPC-CC01	A-7
A-4 EMI Filter.....	A-9
A-5 Speed Feedback Encoder.....	A-12

Appendix B: CANopen Overview

B-1 CANopen Overview	B-3
B-2 Wiring for CANopen	B-6
B-3 CANopen Communication Interface Description	B-7
B-4 CANopen Supporting Index	B-14
B-5 CANopen LED Light Indicator.....	B-15

Appendix C: CANopen Overview

C-1 Activate the Oil Pump, Step by Step	C-1
-----------------------------------------------	-----

Chapter 1 Use and Installation

- 1-1 Product Appearance
- 1-2 Product Specifications
- 1-3 Introduction of Hybrid Energy Saving System
- 1-4 Product Installation
- 1-5 Product Packaging and Dimensions

Upon receipt of the product, the clients are advised to keep the product in its original packaging box. If the machine won't be used temporarily, for future maintenance safety and compliance with the manufacturer's warranty policy, pay attention to the following for product storage:



- Store in a clean and dry location free from direct sunlight or corrosive fumes.
- Store within an ambient temperature range of -20°C to $+60^{\circ}\text{C}$.
- Store within a relative humidity range of 0% to 90% and non-condensing environment.
- Avoid storing the product in environments with caustic gases and liquids.
- Avoid placing the product directly on the ground. The product should be placed on suitable benches and desiccators should be placed in the packaging bags in harsh storage environments.
- Avoid installing the product in places with direct sunlight or vibrations.
- Even if the humidity is within the required value, condensation and freezing can still happen when there is drastic change of temperature. Avoid storing products in such environment.
- If the product has been taken out of the packaging box and in use for over three months, the temperature of the storage environment must be below 30°C . This considers the fact when the electrolytic capacitor is stored with no current conduction and the ambient temperature is too high, its properties may deteriorate. Do not store the product in the situation of no current conduction for more than one year.
- When a hybrid servo controller is installed in a system or in an industrial control panel but not in use (especially in a construction site or in a dusty and humid environment), the hybrid servo controller should be removed and be stored in an environment that meets the storage conditions mentioned above.

1-1 Product Appearance

All Hybrid Energy System has passed strict quality control before being shipped out from the factory, with enforced packaging that sustains impacts. Upon opening the packaging of the Hybrid Energy System, the customers are recommended to conduct the examination by the following steps:

- ☑ Check if there is any damage to Hybrid Energy System during shipping.
- ☑ Upon opening the box, check if the model number of Hybrid Energy System matches that listed on the external box.

For any mismatch of the listed data with your order or any other issues with the product, contact your local agent or retailer.

Nameplate Description:

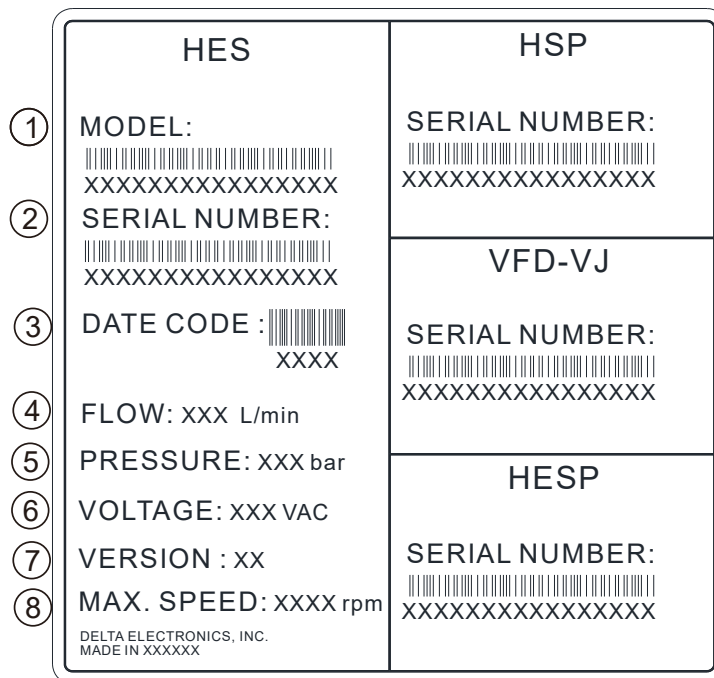

1. MODEL: HES Model Name
2. SERIAL NUMBER:
3. DATE CODE XXXX: First two digits are year, last two digits are week. For example: 2027 means the 27th week of year 2020.
4. FLOW:
5. PRESSURE
6. VOLTAGE: Input voltage 220~240V_{AC} or 380V~480V_{AC}
7. VERSION:
8. MAX. SPEED: Rotating speed to satisfy the system flow rate.

HES Model Name:

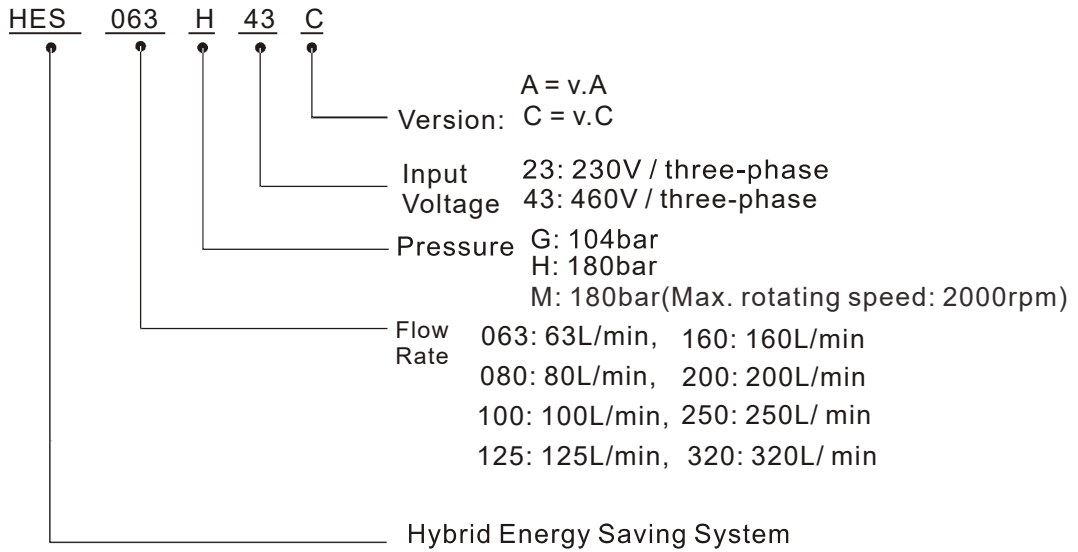

VJ Air Cooled Model Name:

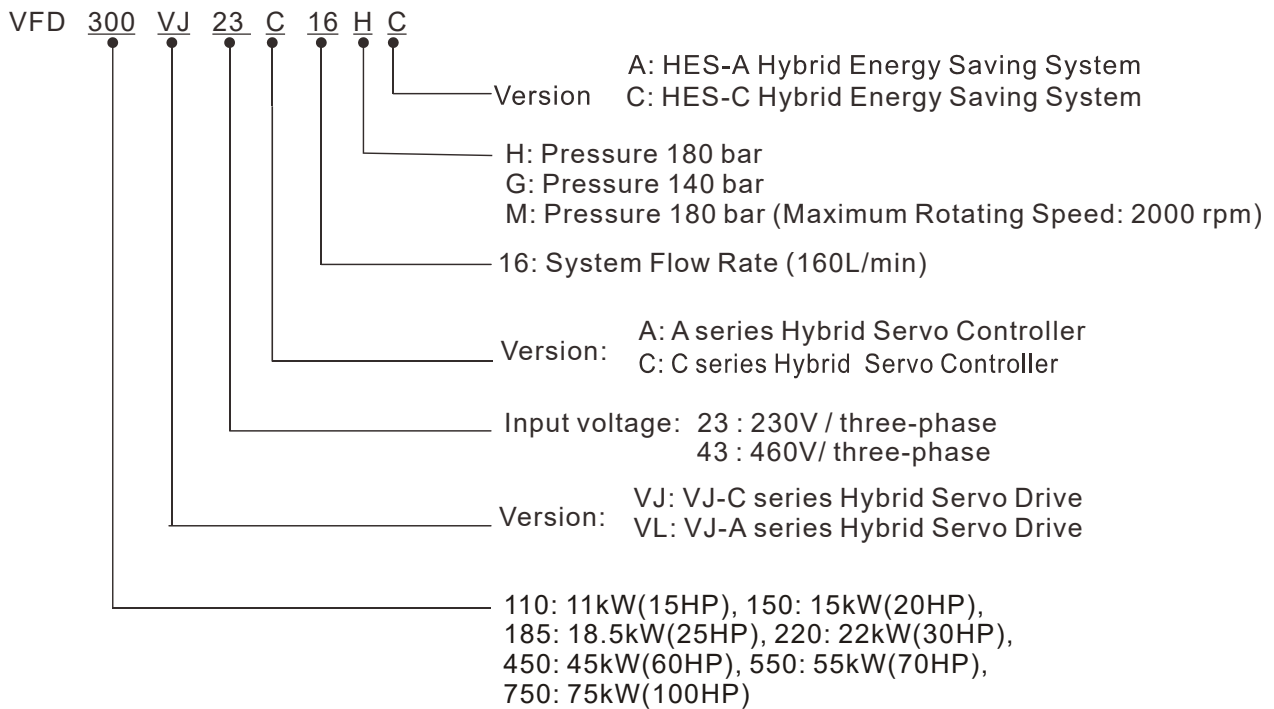

HSP Model Name:

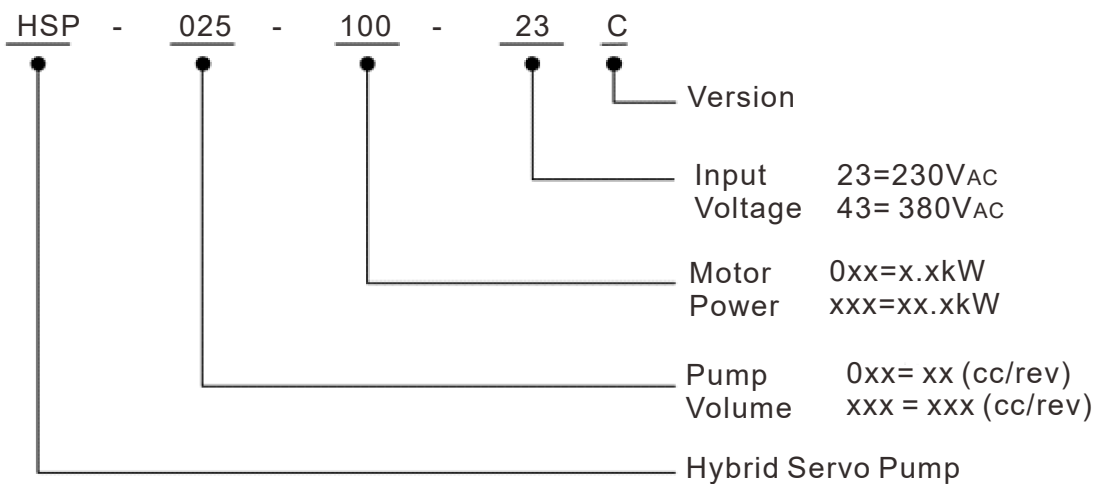



1-2 Specifications

230V Series HES ___ 23C

Model Name			HES ___ 23C						
			063H	080H	100H	125H	160H	200H	250G
HES ID #			2122	3122	4122	5122	6122	7122	8022
Oil Pump Capacity		cc/rev	25	32	40	50	64	80	100
Flow rate Specifications	Flow Rate	L/min	63	80	100	125	160	200	250
	Linearity	%	Below 1% F.S.						
	Magnetic Hysteresis	%	Below 1% F.S.						
Pressure Specifications	Maximum Pressure	Mpa	18	18	18	18	18	18	14
	Minimum Pressure	Mpa	0.1						
	Linearity	%	Below 1% F.S.						
	Magnetic Hysteresis	%	Below 1% F.S.						
Servo Motor Specifications	Model Name HSP-__-__-23C		025-100	032-140	040-140	050-180	064-230	080-270	100-270
	Power	kW	10	14	14	18	23	27	27
	Insulation Class		Class F						
	Certifications								
	Cooling Method		Fan Cooling						
	Ambient Temperature		0 ~ 40 °C						
	Ambient Humidity		20 ~ 90 RH (Non-condensation), altitude < 1000m						
Weight	kg	83	90	90	97	105	121	145	
Servo Controller Specifications	Model Name VFD-__VL23A(L) VFD-__VJ23C(L)		110A (06HC)	150A (08HC)	150A (10HC)	220A (12HC)	300A (16HC)	300A (20HC)	370A (25GC)
	Input Voltage		Three Phase AC 220 ~ 240V, 50/60Hz						
	Rated Output Power	kW	11	15	15	22	30	30	37
	Rated Output Current	A	47	56	56	90	120	120	146
	Continuous output current for 60 sec.	A	62	90	90	119	204	204	248
	Continuous output current for 20 sec.	A	70	106	106	140	240	240	292
	Brake Unit		Built-in						
	Brake Resistor	W	300	1000					
		Ω	8.3	5.8					
	Speed Detector		Resolver						
	Pressure Command Input		0~10V Support three-point calibration / CANopen						
	Flow Rate Command Input		0~10V Support three-point calibration / CANopen						
	Multi-functional Input Terminal		6ch DC24V 8mA / 1 RJ45 (RS485) / 1 RJ45 (CANopen)						
	Multi-functional Output Terminal		2 ch DC48V 50mA / 1 ch Relay output / 1 RJ45 (RS485) / 1 RJ45 (CANopen)						
	Analog Output Voltage		1ch DC 0~10V (AFM1) / 1ch DC -10~10V (AFM2)						
	Comm. Interface	RS485	Terminal (SG+, SG-) / RJ45 (applicable for multi-pump operation)						
		CAN	RJ45						
	Cooling Method		Fan Cooling						
	Protection Functions		Over current, over voltage, low current, overload, or overheating of AC motor drive, overload or overheating of motor, operation speed error						
	Certifications								
Actuation Oil	Working Medium		HL-HLP DIN51 524 Part1/2 R68,R46						
	Operation Temperature	°C	-12 to 100						
	Viscosity	@40 °C	67.83						
@100 °C		8.62							
Miscellaneous		Available upon purchase: safety valve, Reactor, and EMI filter are optional.							

460V Series Specifications HES___43C

Model Name		HES___43C								
		063H	080H	100H	125H	160H	200H	250M	320M	
HES ID #		2142	3142	4142	5142	6142	7142	8342	9342	
Oil Pump Capacity	cc/rev	25	32	40	50	64	80	125	160	
Flow rate Specifications	Flow Rate	L/min	63	80	100	125	160	200	250	320
	Linearity	%	Below 1% F.S.							
	Magnetic Hysteresis	%	Below 1% F.S.							
Pressure Specification	Maximum Pressure	Mpa	18							
	Minimum Pressure	Mpa	0.1							
	Linearity	%	Below 1% F.S.							
	Magnetic Hysteresis	%	Below 1% F.S.							
Servo Motor Specifications	Model Name HSP-___-43C	025-100	032-100	040-140	050-180	064-230	080-250	125-450	165-520	
	Power	kW	10	10	14	18	23	25	45	52
	Insulation Class	Class F								
	Certifications									
	Cooling Method	Fan Cooling								
	Ambient Temperature	0 ~ 40 °C								
	Ambient Humidity	20 ~ 90 RH(No condensation), altitude < 1000m								
	Weight	kg	83	83	90	97	105	121	206	224
Model name VFD-___VJ43□(□)		110□(06HC)	150□(08HC)	185□(10HC)	220□(12HC)	300□(16HC)	300□(20HC)	550□(25MC)	550□(32MC)	
Input Voltage	Three-Phase, 380 ~ 480V, 50/60Hz									
Rated Output Power	kW	11	15	18.5	22	30	30	55	55	
Rated Output Current	A	21	27	34	41	60	60	110	110	
Continuous output current for 60 sec.	A	36	46	58	70	102	102	187	187	
Continuous output current for 20 sec.	A	42	54	68	82	120	120	220	220	
Brake Unit	Built-in									
Brake resistor	W	300	300	1000	1000	1000	1000	1500	1500	
	Ω	25	25	25	25	14	14	13	13	
Speed Detector	Resolver									
Pressure Command Input	0~10V Support three-point calibration									
Flow Rate Command Input	0~10V Support three-point calibration									
Multi-functional Input Terminal	6 ch DC24V 8mA / 1 RJ45(RS485) / 1 RJ45(CANopen)									
Multi-functional Output Terminal	2 ch DC48V 50mA / 1 ch Relay output / 1 RJ45(RS485) / 1 RJ45(CANopen)									
Analog Output Voltage	1 ch DC 0 ~ 10 V (AFM1) / 1 ch DC -10~10V(AFM2)									
Comm. Interface	RS485	Terminal (SG+, SG-) / RJ45 (applicable for multi-pump operation)								
	CAN	RJ45								
Cooling Method	Fan Cooling									
Protection Functions	Over current, over voltage, low current, overload, or overheating of AC motor drive, overload or overheating of motor, operation speed error									
Certifications	 									
Actuation Oil	Working Medium	HL-HLP DIN51 524 Part1/2 R68,R46								
	Operation Temperature	°C	-12 to 100							
	Viscosity	@40 °C	67.83							
@100°C		8.62								
Miscellaneous	Available upon purchase: safety valve, Reactor, and EMI filter are optional.									

1-3 Introduction of Hybrid Energy System

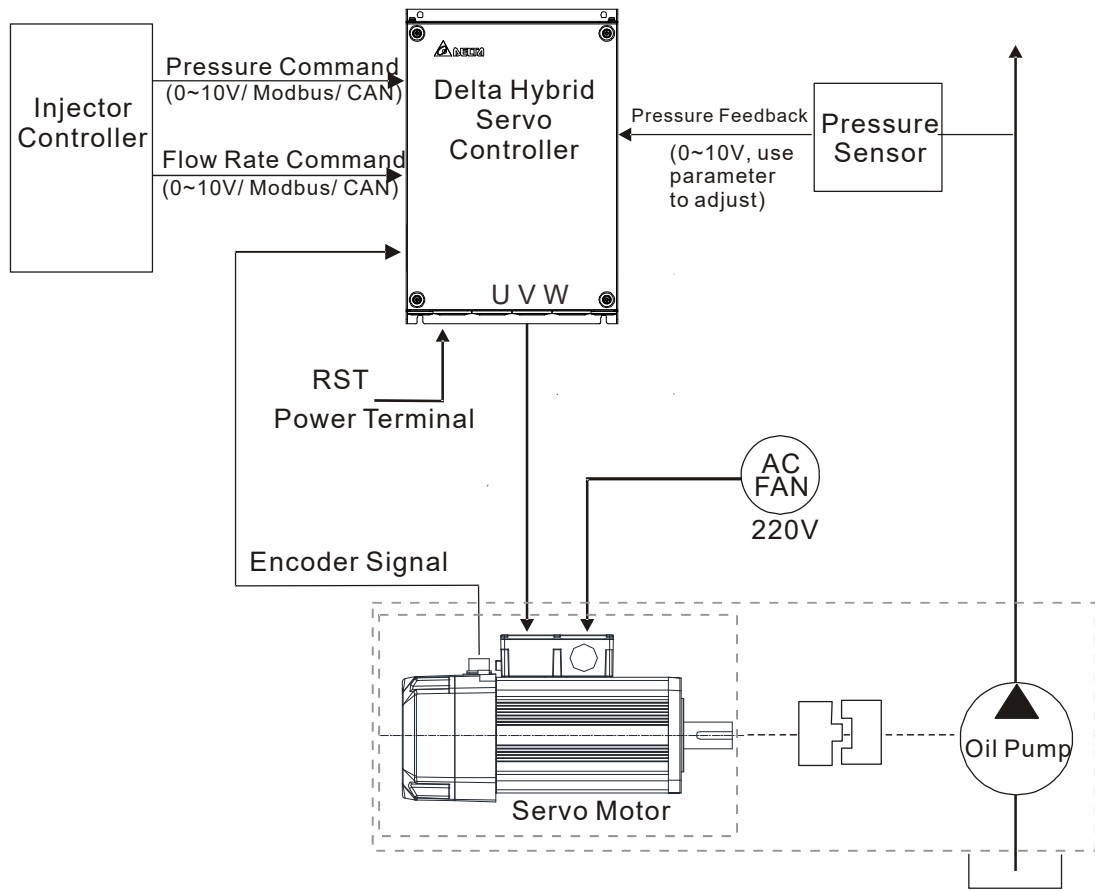

1-4 Installation

Install the hybrid servo controller in the environmental conditions mentioned below to ensure the product safety.

Conditions of Operational Environment	Ambient Temperature	-10°C ~ +45°C (14°F~ 113°F)
	Relative Humidity	<90%, Non-condensing moisture
	Pressure	86 ~ 106 kPa
	Installation Altitude	<1000m
	Vibration	<20Hz: 9.80 m/s ² (1G) max; 20~50Hz: 5.88 m/s ² (0.6G) max
Conditions of Storage and Transportation Environment	Ambient Temperature	-20°C ~ +60°C (-4°F ~ +40°F)
	Relative Humidity	<90%, Non-condensing moisture
	Pressure	86 ~ 106 kPa
	Vibration	<20Hz: 9.80 m/s ² (1G) max; 20 ~ 50Hz: 5.88 m/s ² (0.6G) max
Pollution Level	Level 2: Suitable for low- and medium-pollution factory environment	

Minimum Mounting Clearance and Installation:

Single Drive Installation

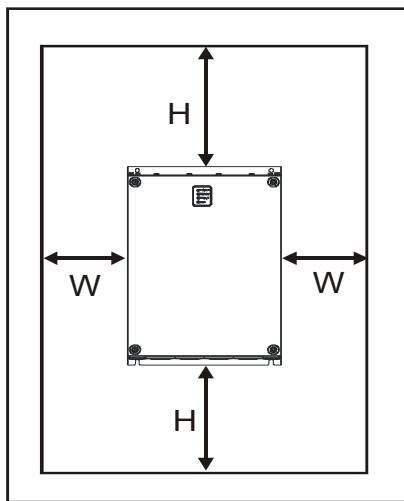

Multi- Drive: Side-by-side horizontal installation

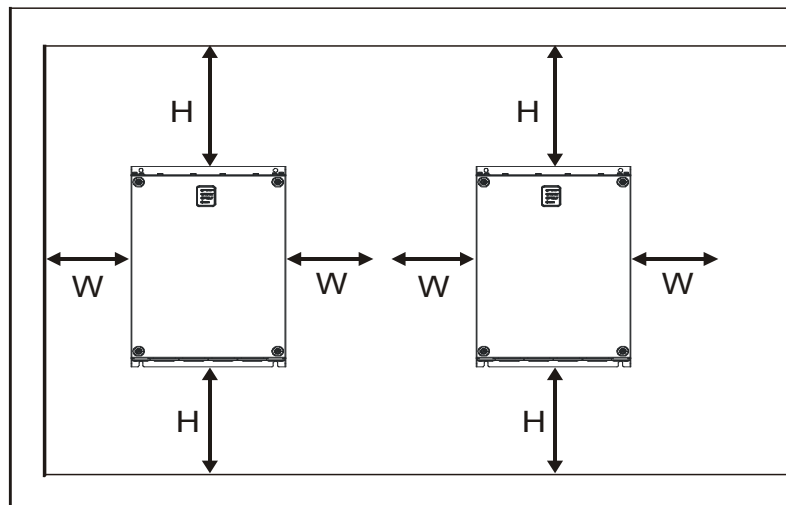

HP	W mm (inch)	H mm (inch)
7.5-20HP	75 (3)	175 (7)
25-75HP	75 (3)	200 (8)
100HP	75 (3)	250 (10)

- ☑ Install the hybrid servo controller vertically on a sturdy structure with screws. Do not install it upside down or horizontally.
- ☑ A hybrid servo controller generates heat when it's running. Lave enough space to ensure a good circulation of cooling air as shown in the image below. The heat generated during the operation diffuses upward, so do not install a hybrid servo controller under an equipment which is not heat resistant. If you install a hybrid servo controller in a control pane / cabinet, you need to consider the ventilation and heat dissipation condition to make sure that the surrounding temperature of the hybrid servo controller does not exceed the specified value. Do not install a hybrid servo controller in a closed space with poor ventilation and heat dissipation, which could result in malfunction.

- ☑ When a hybrid servo controller is running, the temperature of the heat sink varies with the ambient temperature and load. The maximum temperature increases to nearly 90 °C. In this case, the mounting surface on the back of the hybrid servo controller must be made of materials that can hold up higher temperatures.
- ☑ When you install multiple hybrid servo controllers in the same control panel / cabinet, in order to reduce the mutual-thermal implication, the side by side horizontal installation is recommended. If the up and down installation is required, install a partition plate between the hybrid servo drives to reduce the implication of the heat generated from the lower part one the upper one.

NOTE:

Do not let any foreign objects such as fiber, paper pieces, wood chips or metal pieces to adhere to the cooling fan of the hybrid servo motor. The product should be installed in a control panel / cabinet made of inflammable materials such as metal to avoid the risk of fire.

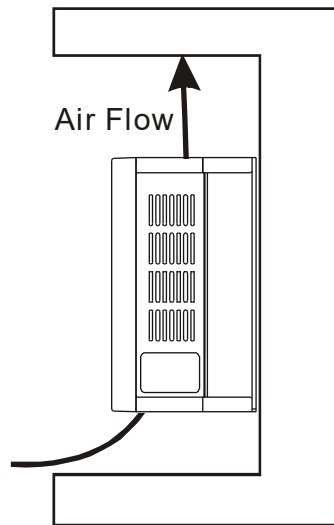

	Model Name	Heat Dissipation Rate(W)	Air Volume of Heat Dissipation (CFM)
460V Air Cooled	VFD110VL43C-J	383.6	50
	VFD150VL43C-J	404.1	50
	VFD185VL43C-J	500.5	50
	VFD220VL43C-J	580.9	50
	VFD300VL43C-J	1037.8	133
	VFD370VL43C-J	1078.7	133
	VFD450VL43C-J	1370.1	209
	VFD550VL43C-J	1536.5	209

- ☑ The numbers in the table above show the heat released due to the loss when you install a single unit of hybrid servo drive in a confined space.
- ☑ Heat released when you install multi-unit = Number of unit installed x heat released by a single unit.
- ☑ By calculating the rated voltage, rated current and the default carrier frequency of each model, we obtain the numbers in the table above.

Servo Oil Pump:

Install the servo oil pump in an environment with the following conditions to ensure safe product operation::

Conditions of Operation Environment	Ambient Temperature	0°C~ 40°C
	Relative Humidity	20%~90%, Non-condensing moisture
	Oil Temperature	0°C~ 60°C (15°C~ 50°C is recommended)

- ☑ A hybrid servo controller generates heat when it's running. Lave enough space to ensure a good circulation of cooling air Do not let any foreign objects such as fiber, paper pieces, wood chips or metal pieces to adhere to the cooling fan of the hybrid servo motor. When a hybrid servo controller is running, the temperature of the enclosure varies with the ambient temperature and load. The maximum temperature increases to nearly 100 °C. Do NOT touch it with your hands to avoid heat burn.

HES version C

The image below shows that HES-C is installed on a platform. Beside absorbing the vibration produced by the running motor, the height and the position of the anti-vibration rubber pads can also be adjusted.

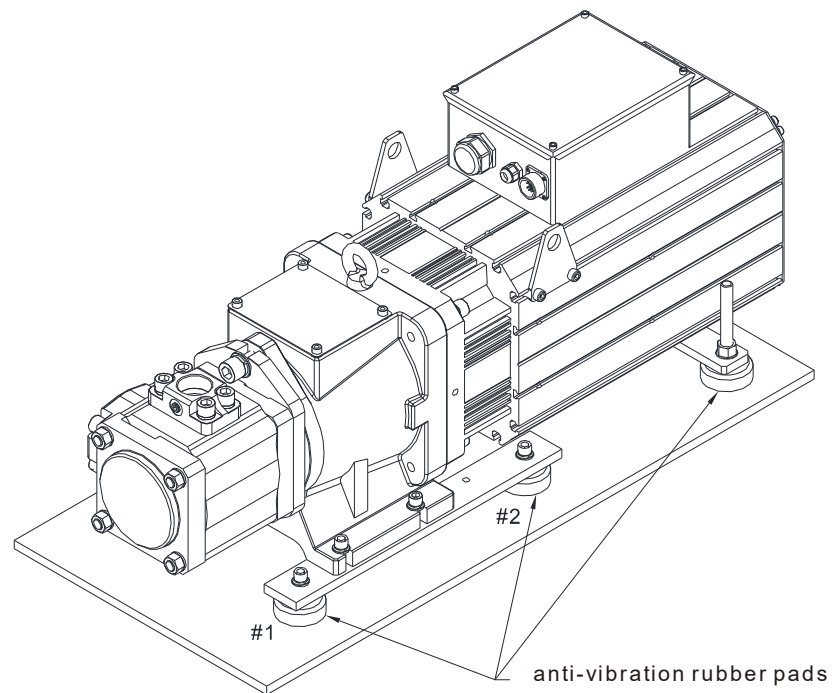
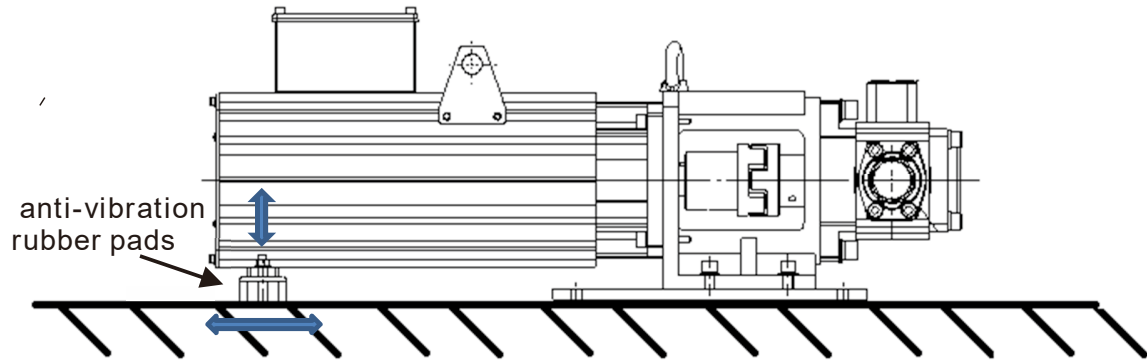

Anti-vibration rubber heads #1 and #2 are optional, your need to install them on your own.

Pipelines & Connections

- Remove all protection caps on the pump
- Choose suitable oil tube and connector (Maximum intake flow rate 1m/s)

Recommended Specifications of oil inlet tube		
Flow Rate(L/min)	Tube Diameter (inch)	Length (m)
80	Above 1.5	Within 1.5
100	Above 1.5	Within 1.5
125	Above 2	Within 1.5
160	Above 2.25	Within 1.5
200	Above 2.5	Within 1.5
250	Above 3.0	Within 1.5
320	Above 3.5	Within 1.5

- Absolute intake oil pressure: Maximum 2 bar
- Prior to assembly, the iron dusts in the connectors and oil tubes must be removed.
- The filter for the oil inlet must be above 150mesh.

 **NOTE**

1. For your safety, install safety valve in the oil line loop. Do not add check valve to the oil outlet of the oil pump to avoid poor response of Hybrid Energy Saving System.
2. Prior to assembly, the iron dusts in the connectors and oil tubes must be removed to ensure oil quality and to prevent damages on the servo oil pump and the pressure sensor.

HES model name	Servo Oil Pump model name	Oil outlet flange locking screw specification	Oil outlet flange locking Torque force	Oil inlet flange locking screw specification	Oil inlet flange locking Torque force (Nm)	Specifications of oil inlet tube	
						Tube Diameter (inch)	Length (m)
HES063H23C	HSP-025-100-23C	M10-40mm	49Nm	M10-35mm	49	1.5	1.5
HES063H43C	HSP-025-100-43C	M10-40mm	49Nm	M10-35mm	49	1.5	1.5
HES080H23C	HSP-032-140-23C	M10-40mm	49Nm	M10-35mm	49	1.5	1.5
HES080H43C	HSP-032-100-43C	M10-40mm	49Nm	M10-35mm	49	1.5	1.5
HES100H23C	HSP-040-140-23C	M10-40mm	49Nm	M10-35mm	49	1.5	1.5
HES100H43C	HSP-040-140-43C	M10-40mm	49Nm	M10-35mm	49	1.5	1.5
HES125H23C	HSP-050-180-23C	M10-40mm	49Nm	M10-35mm	49	2.0	1.5
HES125H43C	HSP-050-180-43C	M10-40mm	49Nm	M10-35mm	49	2.0	1.5
HES160H23C	HSP-064-230-23C	M10-40mm	49Nm	M10-35mm	49	2.25	1.5
HES160H43C	HSP-064-230-43C	M10-40mm	49Nm	M10-35mm	49	2.25	1.5
HES200H23C	HSP-080-270-23C	M14-55mm	115Nm	M12-45mm	80	2.5	1.5
HES200H43C	HSP-080-250-43C	M14-55mm	115Nm	M12-45mm	80	2.5	1.5
HES250G23C	HSP-100-270-23C	M14-55mm	115Nm	M12-45mm	80	3.0	1.5
HES250M43C	HSP-125-450-43C	M16-55mm	200Nm	M12-45mm	80	3.0	1.5
HES320M43C	HSP-160-520-43C	M16-55mm	200Nm	M16-45mm	200	3.0	1.5

1-5 Product Packaging and Dimensions



- ☑ This product is made by a manufacturing process with strict quality control. If the product is damaged in the delivery by external force or crushing, please contact your local agents.

1-5-1 Descriptions of Product Packaging

Applicable Models

HES063H23C
HES063H43C
HES080H23C
HES080H43C
HES100H23C
HES100H43C
HES125H23C
HES125H43C
HES160H23C
HES160H43C
HES200H23C
HES200H43C
HES250G23C
HES250M43C
HES320M43C

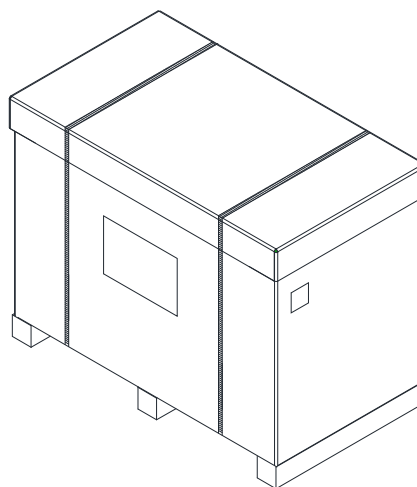
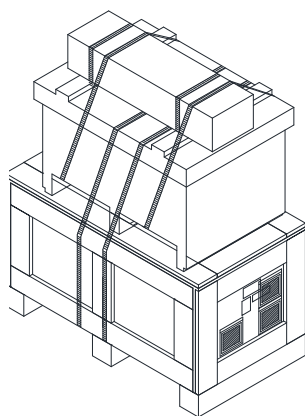

01. HES063H23C

1 servo controller: VFD110VL23A06HC

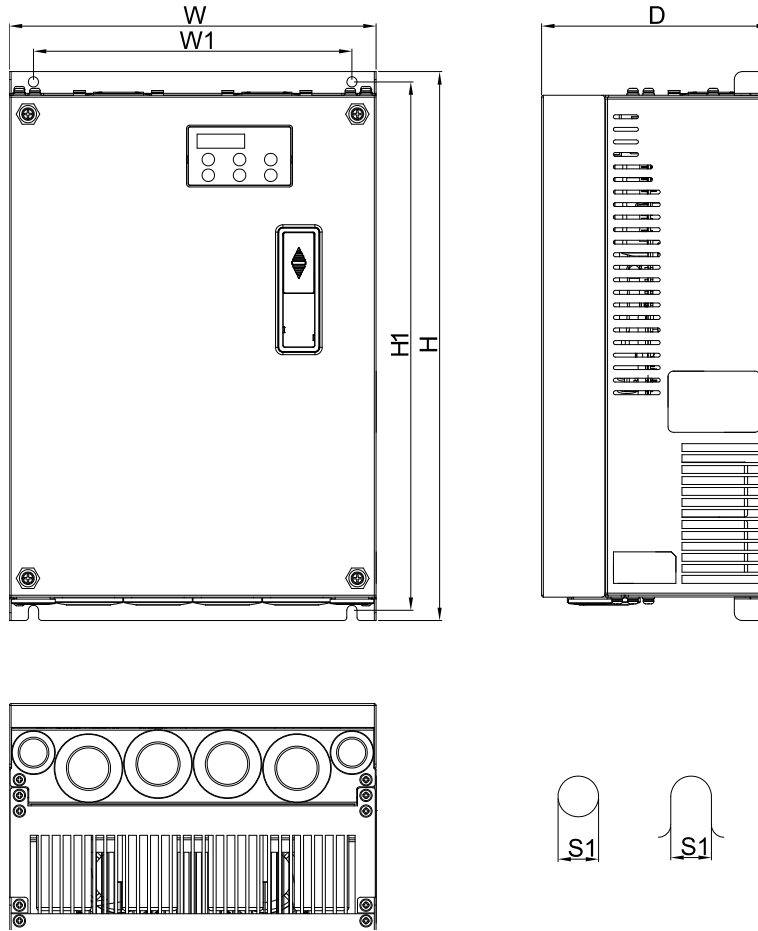

Frame		W	H	D	W1	H1	S1
C	mm	235	350	146	204	337	6.5
	inch	9.25	13.78	5.75	8.03	13.27	0.26

Unit: mm[inch]

2 Servo Oil Pump: HSP-025-100-23C

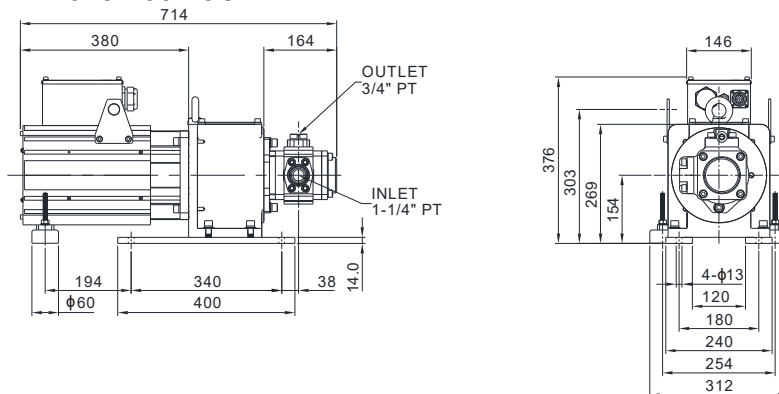

Component	Model Name	Quantity
Motor	MSJ-DR201AE42C	1
Oil Pump	EIPC3, 25cc/rev	1

3 Accessory Kit: HESP-063-H-NC23

Component	Model Name	Quantity
Braking Resistor	BR300W8P3 (MH300W)	1
Pressure Sensor		1
Anti-interference magnetic ring		3
Sensor clamp		1
casing tube head		1

NOTE: An encoder cable is included in the HSP Servo Oil Pump package.
(Model Name: CBHE-E5M)



4: Braking Resistor: BR300W8P3 (MH300W)

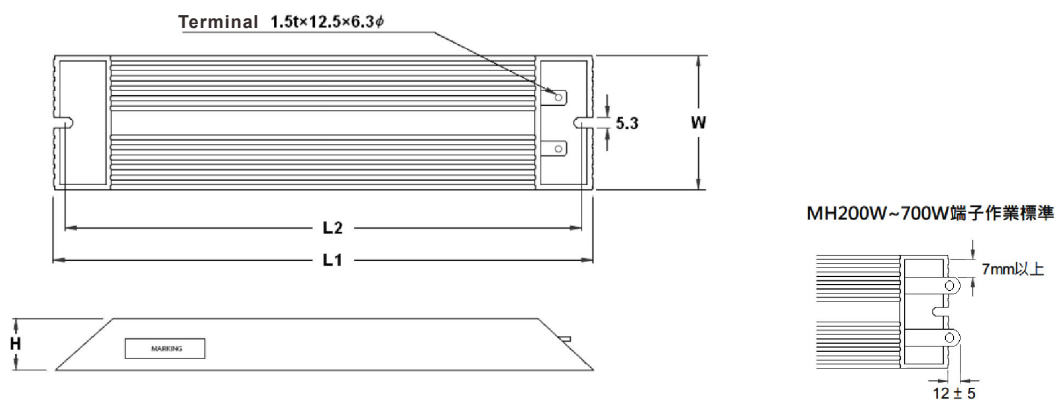

Unit: mm

TYPE	L1 ± 2	L2 ± 2	W ± 0.5	H ± 0.5
MH 300 W	215	200	60	30

02. HES080H23C

1 servo controller: VFD150VL23A08HC:

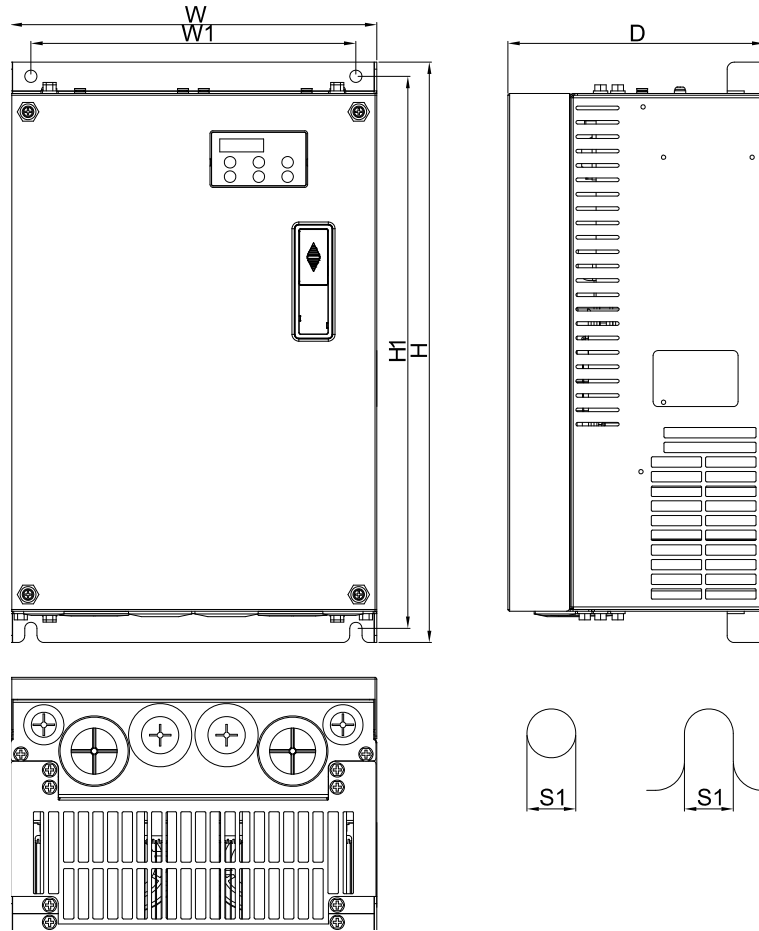

Frame		W	H	D	W1	H1	S1
D	mm	255	403.8	178.0	226.0	384	8.5
	inch	10.04	15.90	7.00	8.90	15.12	0.33

Unit: mm[inch]

2 Servo Oil Pump: HSP-032-140-23C

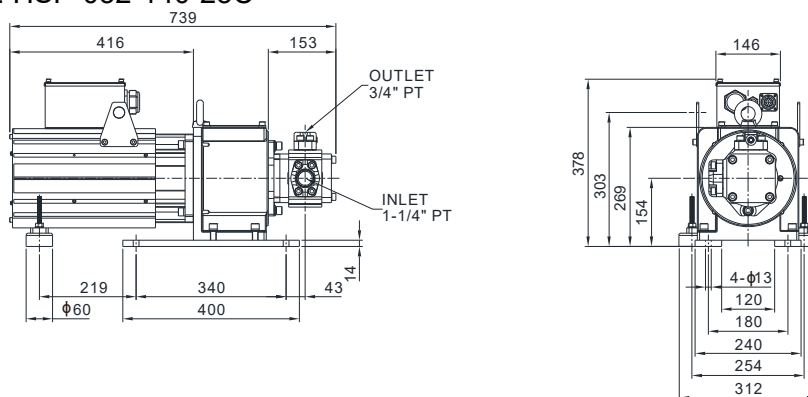

Component	Model Name	Quantity
Motor	MSJ-DR201EE42C	1
Oil Pump	EIPC3, 32cc/rev	1

3 Accessory Kit: HESP-080-H-NC23

Component	Model Name	Quantity
Braking Resistor	BR1K0W5P8 (MH1000W)	1
Pressure Sensor		1
Anti-interference magnetic ring		3
Sensor clamp		1
casing tube head		1

NOTE: An encoder cable is included in the HSP Servo Oil Pump package.
(Model Name: CBHE-E5M)



4 Braking Resistor: BR1K0W5P8 (MH1000W)

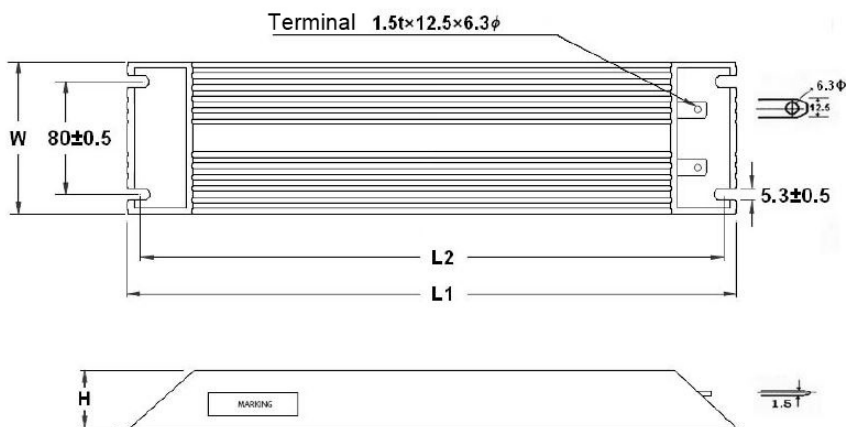

Unit: mm

TYPE	L1 ± 2	L2 ± 2	W ± 0.5	H ± 0.5
MH 1000 W	400	385	100	50

03. HES100H23C

1 servo controller: VFD150VL23A10HC

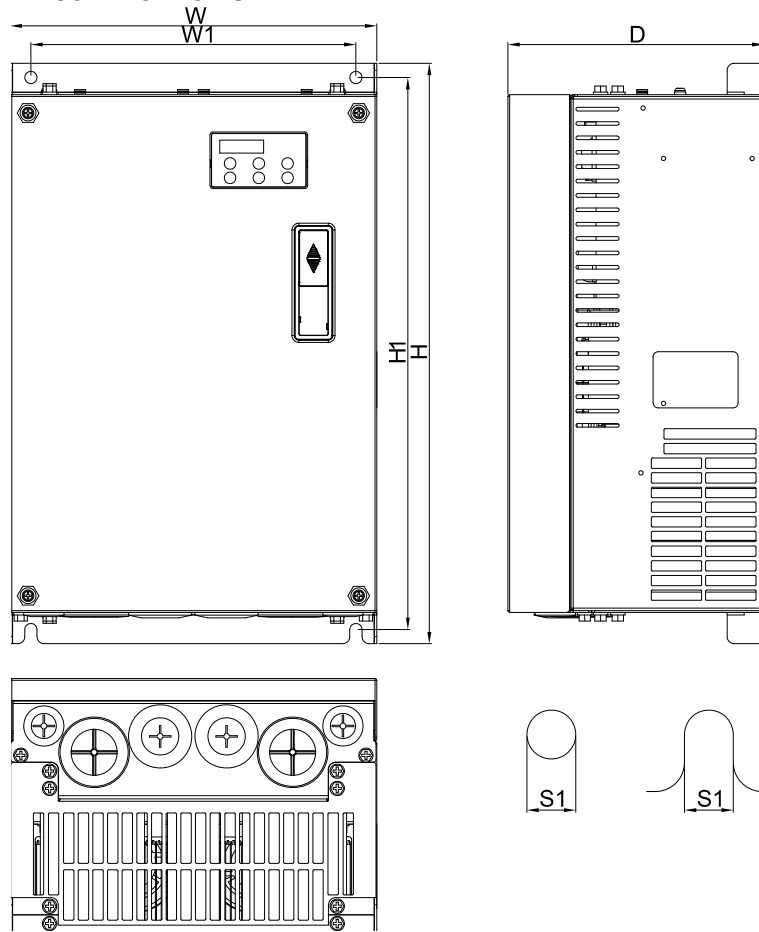

Frame		W	H	D	W1	H1	S1
D	mm	255	403.8	178.0	226.0	384	8.5
	inch	10.04	15.90	7.00	8.90	15.12	0.33



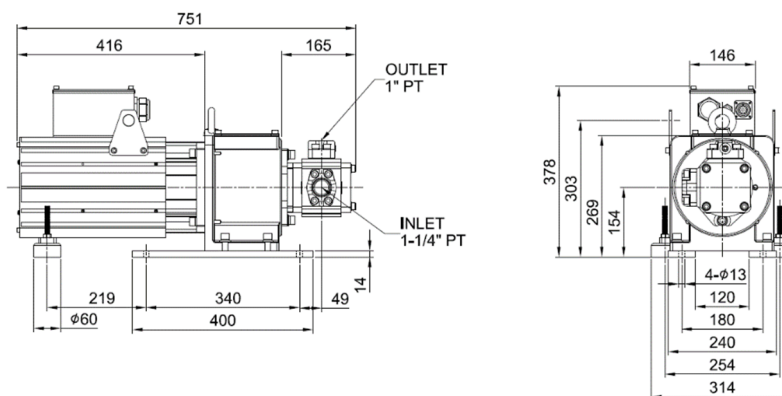

Unit: mm[inch]

2 Servo Oil Pump: HSP-040-140-23C



Component	Model Name	Quantity
Motor	MSJ-DR201EE42C	1
Oil Pump	EIPC3, 40cc/rev	1

3 Accessory Kit: HESP-100-H-NC23:

Component	Model Name	Quantity
※ Braking Resistor	BR1K0W5P8 (MH1000W)	1
Pressure Sensor		1
Anti-interference magnetic ring		3
Sensor clamp		1
casing tube head		1

NOTE: An encoder cable is included in the HSP Servo Oil Pump package.
(Model Name: CBHE-E5M)



4 Braking Resistor: : BR1K0W5P8 (MH1000W)

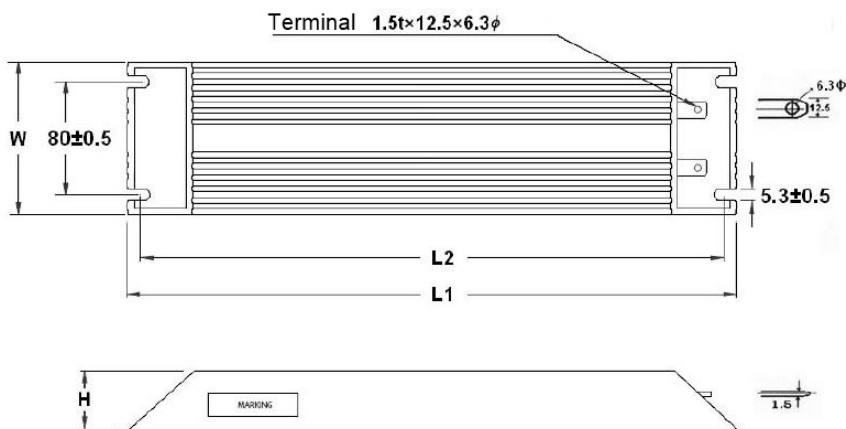

Unit: mm

TYPE	L1 ± 2	L2 ± 2	W ± 0.5	H ± 0.5
MH 1000 W	400	385	100	50

04. HES125H23C

1 servo controller: VFD220VL23A12HC

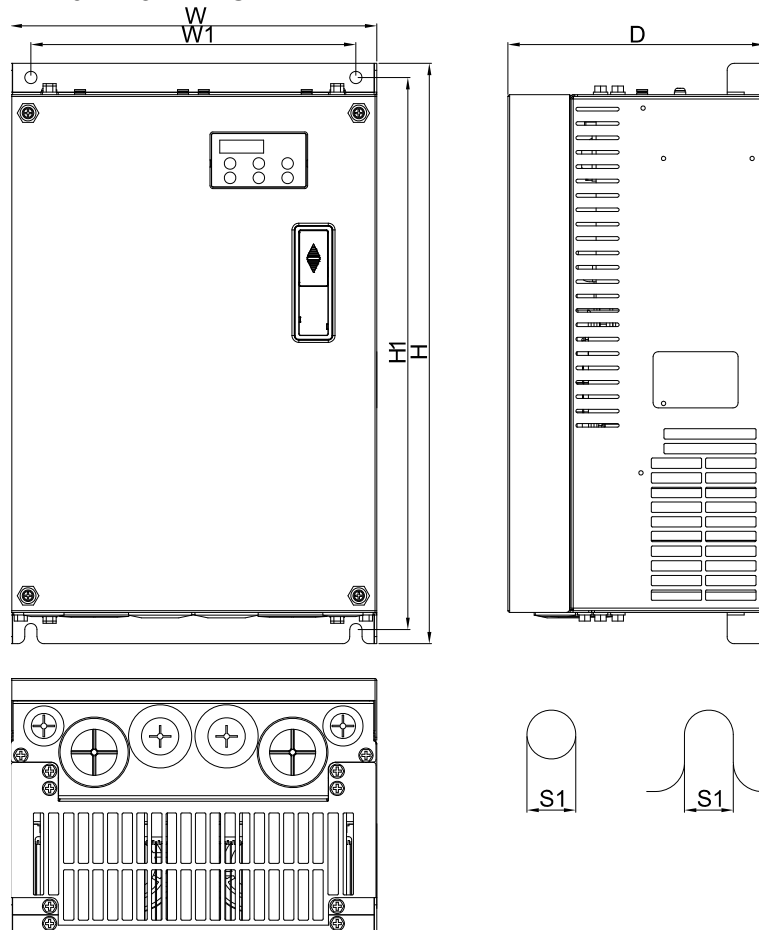

Frame		W	H	D	W1	H1	S1
D	mm	255	403.8	178.0	226.0	384	8.5
	inch	10.04	15.90	7.00	8.90	15.12	0.33



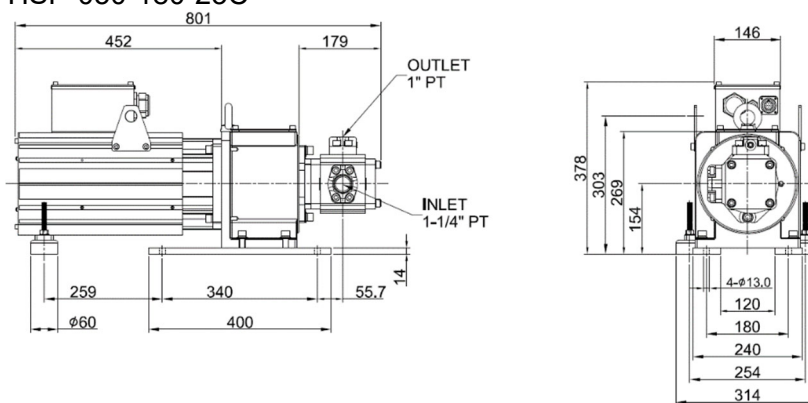

Unit: mm[inch]

2 Servo Oil Pump: HSP-050-180-23C



Component	Model Name	Quantity
Motor	MSJ-DR2011E42C	1
Oil Pump	EIPC3, 50cc/rev	1

3 Accessory Kit: HESP-125-H-NC23

Component	Model Name	Quantity
Braking Resistor	BR1K0W5P8 (MH1000W)	1
Pressure Sensor		1
Anti-interference magnetic ring		3
Sensor clamp		1
casing tube head		1

NOTE: An encoder cable is included in the HSP Servo Oil Pump package.
(Model Name: CBHE-E5M)



4 Braking Resistor: BR1K0W5P8 (MH1000W)

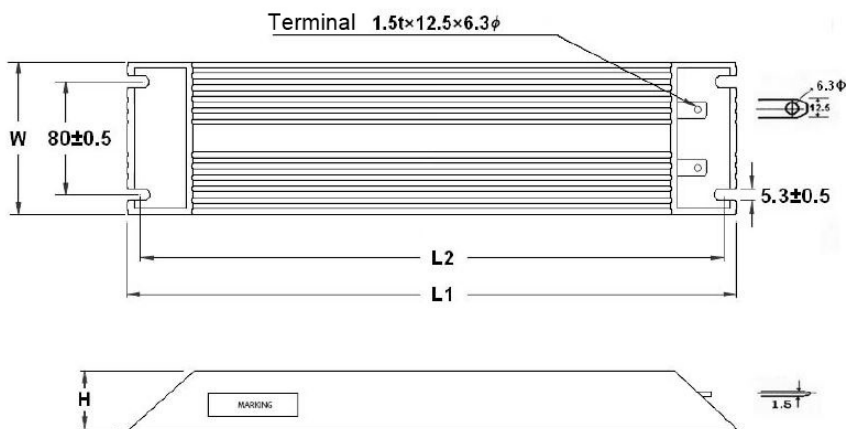

Unit: mm

TYPE	L1 ± 2	L2 ± 2	W ± 0.5	H ± 0.5
MH 1000 W	400	385	100	50

05. HES160H23C

1 servo controller: VFD300VL23C16HC

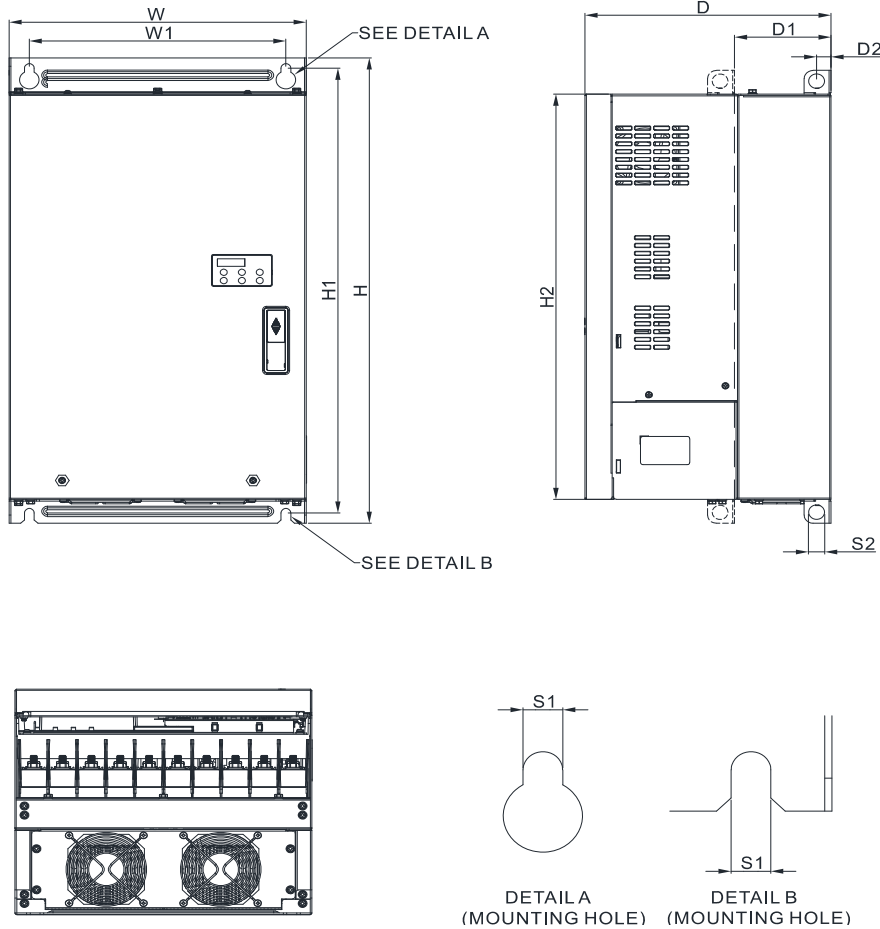

E4	mm	330.0	565.0	273.4	285.0	540.0	492.0	107.2	16.0	11.0	18.0
	inch	12.99	22.24	10.76	11.22	20.67	19.37	4.22	0.63	0.43	0.71

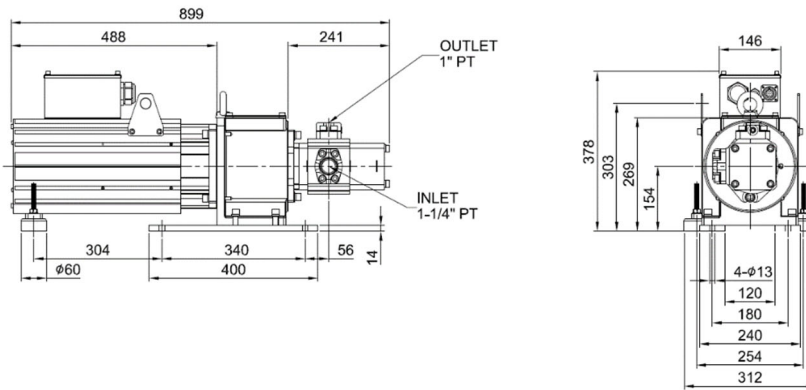

Unit: mm[inch]

2 Servo Oil Pump: HSP-064-230-23C



Component	Model Name	Quantity
Motor	MSJ-GR202DE42C	1
Oil Pump	EIPC3, 64cc/rev	1

3 Accessory Kit: HESP-160-H-BC23

Component	Model Name	Quantity
Braking Resistor	BR1K0W5P8 (MH1000W)	1
Pressure Sensor		1
Anti-interference magnetic ring		3
Sensor clamp		1
casing tube head		1

NOTE: An encoder cable is included in the HSP Servo Oil Pump package.
(Model Name: CBHE-E5M)



4 Braking Resistor: BR1K0W5P8 (MH1000W)

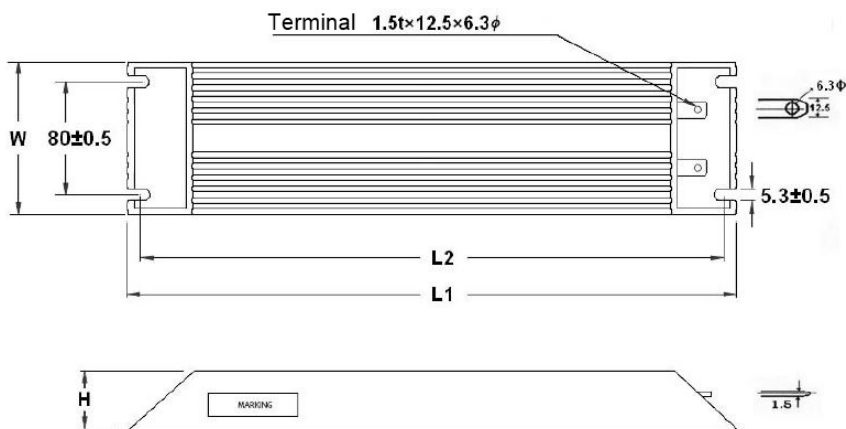

Unit: mm

TYPE	L1 ± 2	L2 ± 2	W ± 0.5	H ± 0.5
MH 1000 W	400	385	100	50

06. HES200H23C

1 servo controller: VFD300VL23A20HC

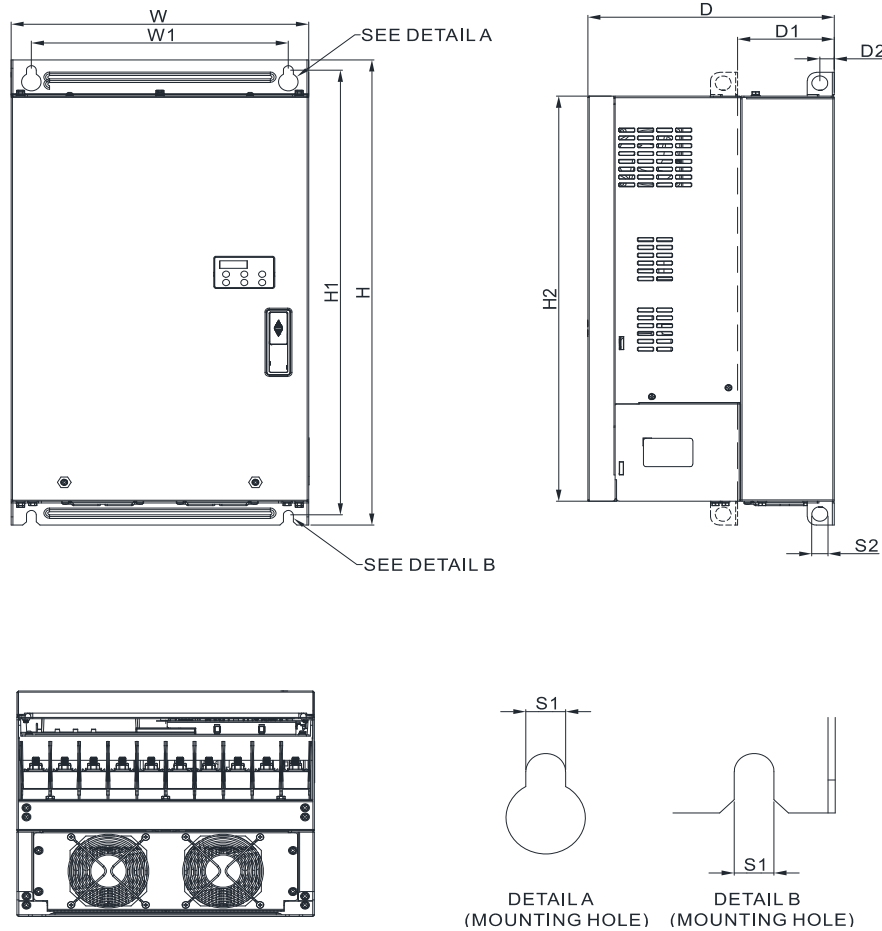

Frame		W	H	D	W1	H1	H2	D1	D2	S1	S2
E4	mm	330.0	565.0	273.4	285.0	540.0	492.0	107.2	16.0	11.0	18.0
	inch	12.99	22.24	10.76	11.22	20.67	19.37	4.22	0.63	0.43	0.71



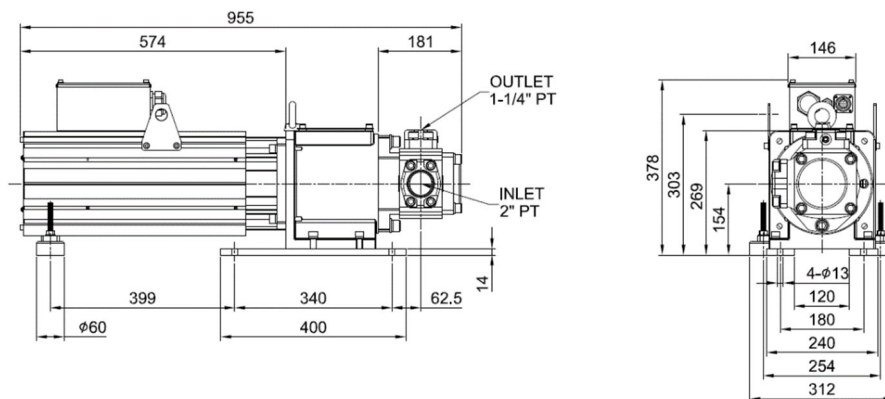

Unit: mm[inch]

2 Servo Oil Pump: HSP-080-270-23C



Component	Model Name	Quantity
Motor	MSJ-DR202HE42C	1
Oil Pump	EIPC5, 80cc/rev	1

3 Accessory Kit: HESP-200-H-BC23

Component	Model Name	Quantity
Braking Resistor	BR1K0W5P8 (MH1000W)	1
Pressure Sensor		1
Anti-interference magnetic ring		3
Sensor clamp		1
casing tube head		1

NOTE: An encoder cable is included in the HSP Servo Oil Pump package.
(Model Name: CBHE-E5M)



4 Braking Resistor: BR1K0W5P8 (MH1000W)

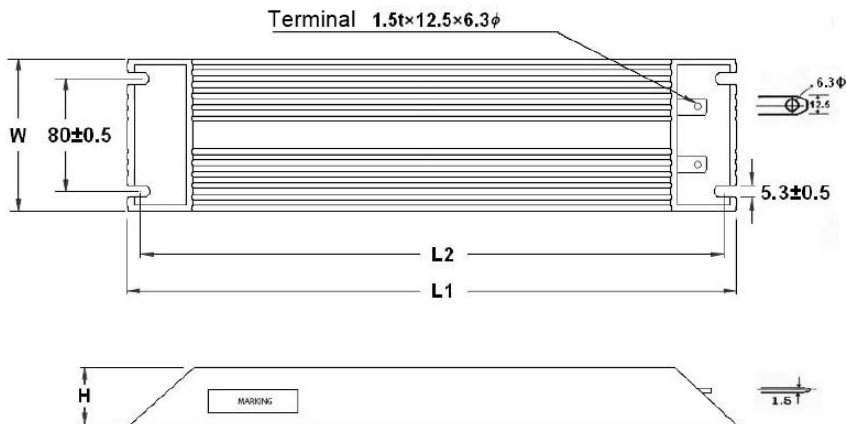

Unit: mm

TYPE	L1 ± 2	L2 ± 2	W ± 0.5	H ± 0.5
MH 1000 W	400	385	100	50

07. HES250G23C

1 servo controller: VFD370VJ23C25GC

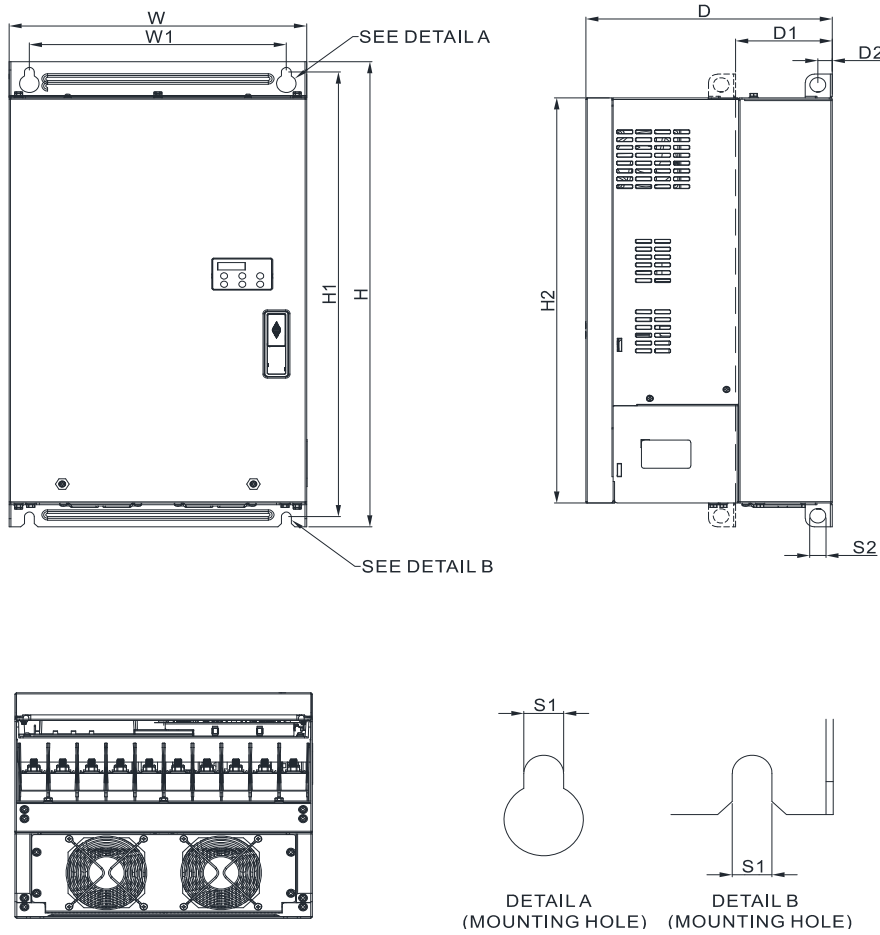

Frame		W	H	D	W1	H1	H2	D1	D2	S1	S2
E4	mm	330.0	565.0	273.4	285.0	540.0	492.0	107.2	16.0	11.0	18.0
	inch	12.99	22.24	10.76	11.22	20.67	19.37	4.22	0.63	0.43	0.71

Unit: mm[inch]

2 Servo Oil Pump: HSP-100-270-23C

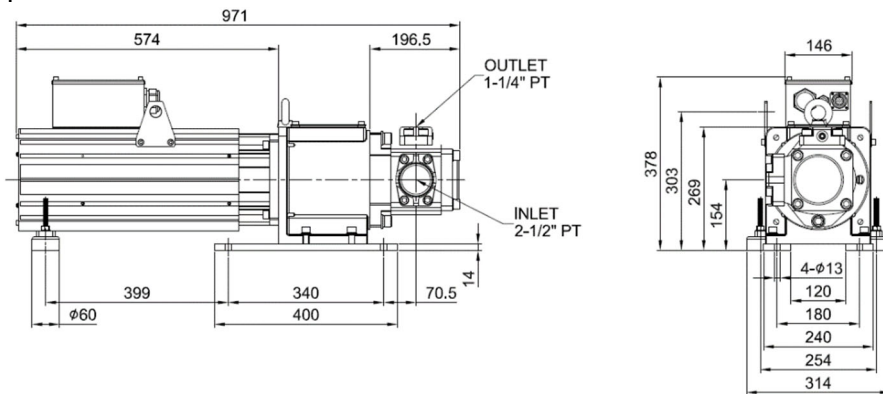

Component	Model Name	Quantity
Motor	MSJ-DR202HE42C	1
Oil Pump	EIPC5, 100cc/rev	1

3 Accessory Kit: HESP-250-G-BC23

Component	Model Name	Quantity
Braking Resistor	BR1K0W5P8 (MH1000W)	1
Pressure Sensor		1
Anti-interference magnetic ring		3
Sensor clamp		1
casing tube head		1

NOTE: An encoder cable is included in the HSP Servo Oil Pump package.
(Model Name: CBHE-E10M)



4 Braking Resistor: BR1K0W5P8 (MH1000W)

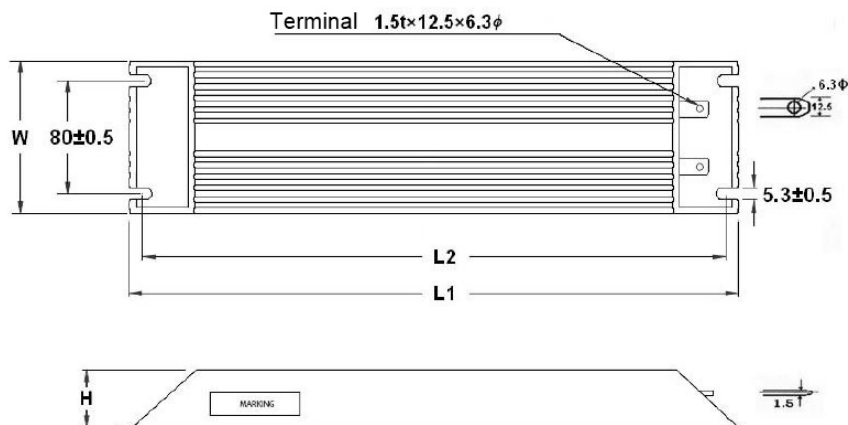

Unit: mm

TYPE	L1 ± 2	L2 ± 2	W ± 0.5	H ± 0.5
MH 1000 W	400	385	100	50

08. HES063H43C

1 servo controller: VFD110VJ43C06HC

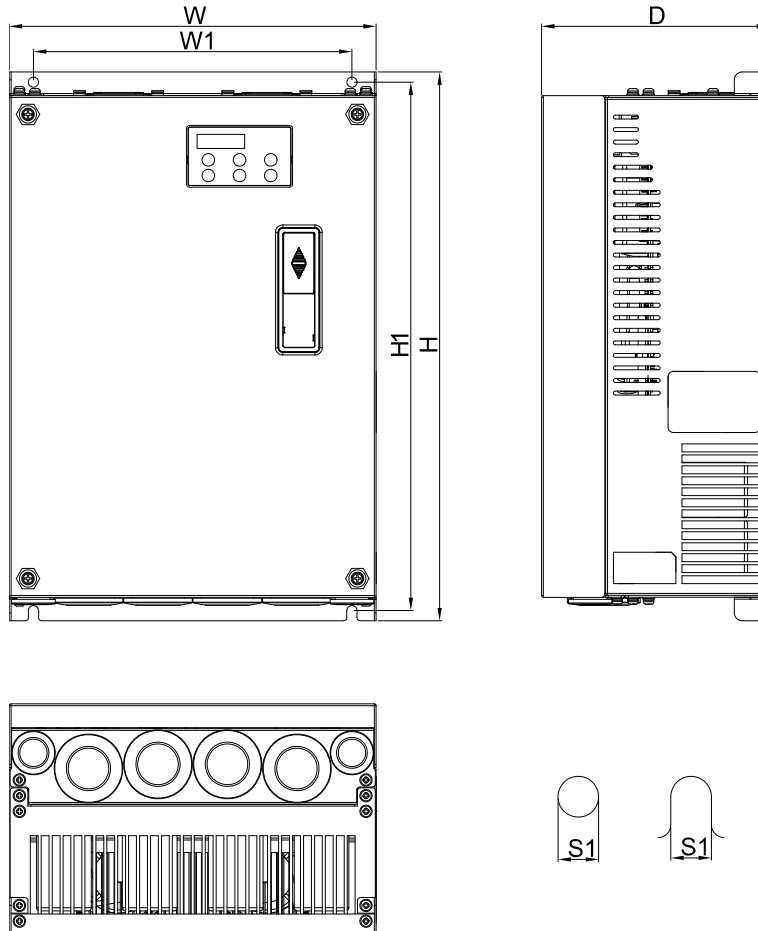

C	mm	235	350	146	204	337	6.5
	inch	9.25	13.78	5.75	8.03	13.27	0.26

Unit: mm[inch]

2 Servo Oil Pump: HSP-025-100-43C

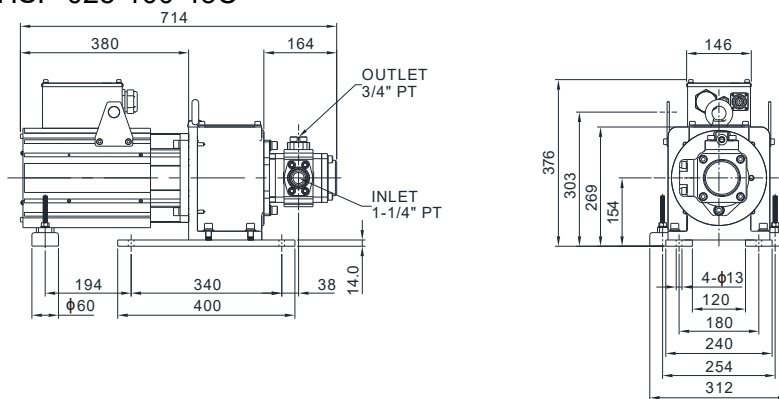

Component	Model Name	Quantity
Motor	MSJ-IR201AE42C	1
Oil Pump	EIPC3, 25cc/rev	1

3 Accessory Kit: HESP-063-H-NC43

Component	Model Name	Quantity
Braking Resistor	BR300W031(MH300W)	1
Pressure Sensor		1
Anti-interference magnetic ring		1
Sensor clamp		1
casing tube head		1

NOTE: An encoder cable is included in the HSP Servo Oil Pump package.
(Model Name: CBHE-E5M)



4 Braking Resistor: BR300W031(MH300W)

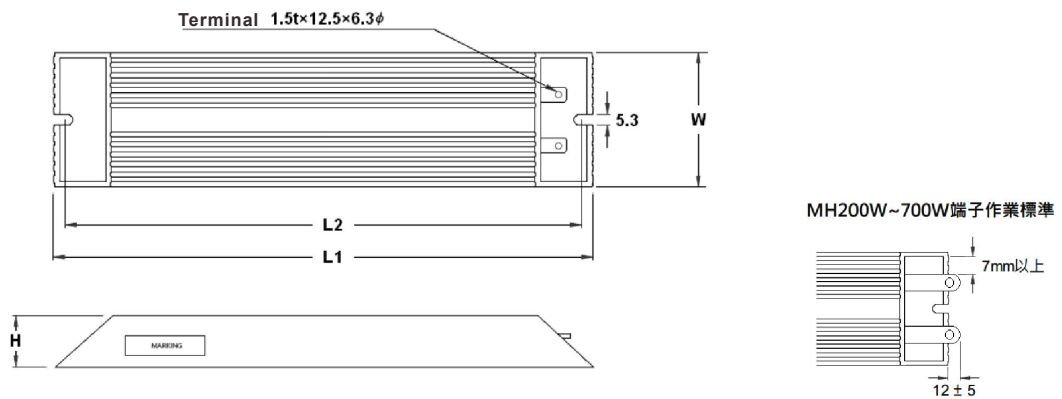

Unit: mm

TYPE	L1 ± 2	L2 ± 2	W ± 0.5	H ± 0.5
MH 300 W	215	200	60	30

09. HES080H43C

1 servo controller: VFD150VJ43C08HC

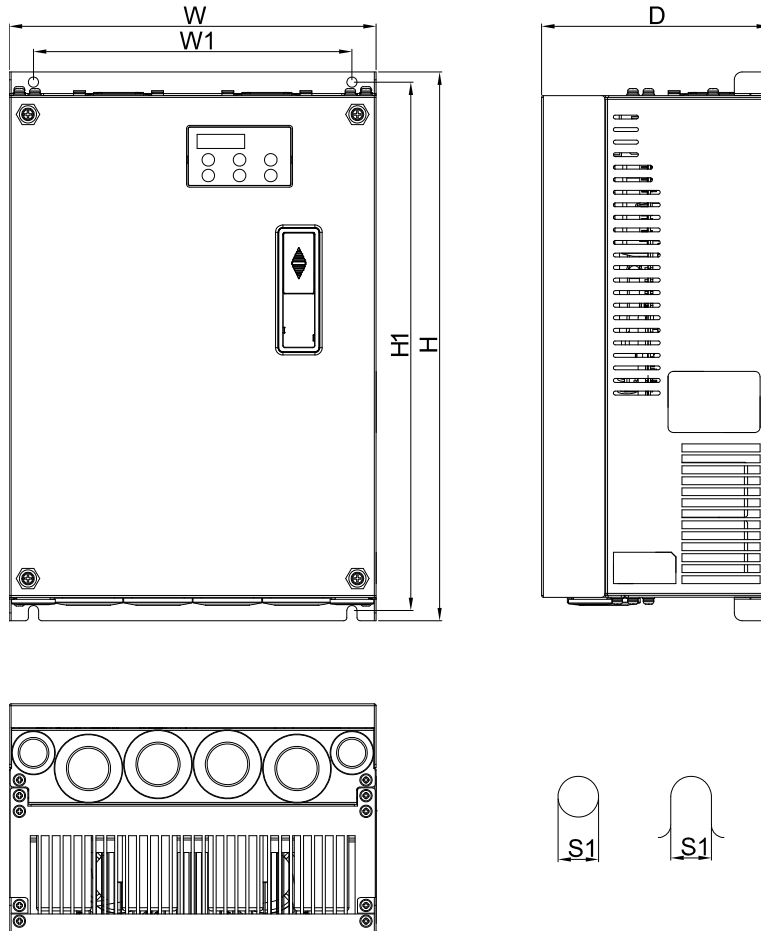

C	mm	235	350	146	204	337	6.5
	inch	9.25	13.78	5.75	8.03	13.27	0.26

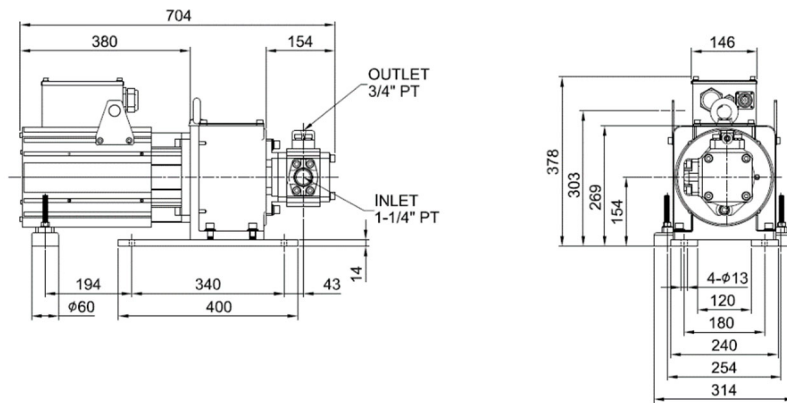

Unit: mm[inch]

2 Servo Oil Pump: HSP-032-100-43C



Component	Model Name	Quantity
Motor	MSJ-IR201AE42C	1
Oil Pump	EIPC3, 32cc/rev	1

3 Accessory Kit: HESP-080-H-NC43

Component	Model Name	Quantity
Braking Resistor	BR300W025 (MH300W)	1
Pressure Sensor		1
Anti-interference magnetic ring		1
Sensor clamp		1
casing tube head		1

NOTE: An encoder cable is included in the HSP Servo Oil Pump package.
(Model Name: CBHE-E5M)



4 Braking Resistor: BR300W025 (MH300W)

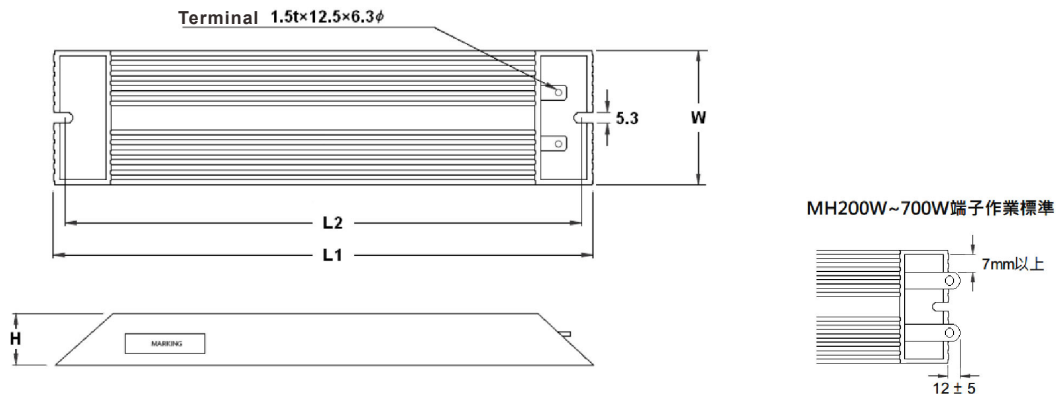

Unit: mm

TYPE	L1 ± 2	L2 ± 2	W ± 0.5	H ± 0.5
MH 300 W	215	200	60	30

10. HES100H43C

1 servo controller: VFD185VJ43C10HC

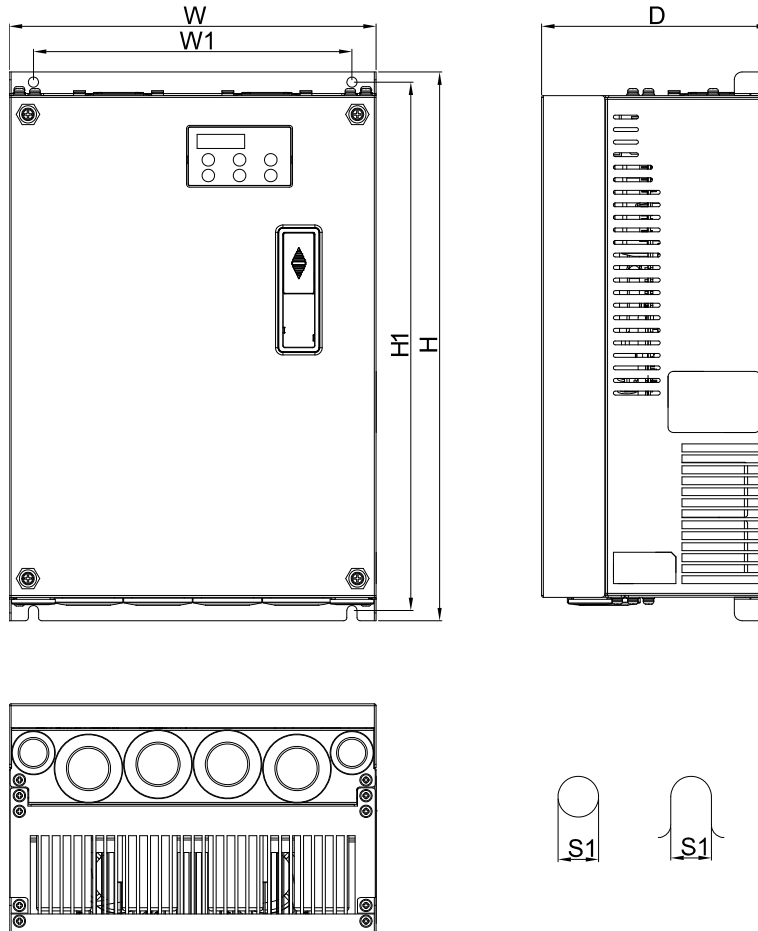

C	mm	235	350	146	204	337	6.5
	inch	9.25	13.78	5.75	8.03	13.27	0.26



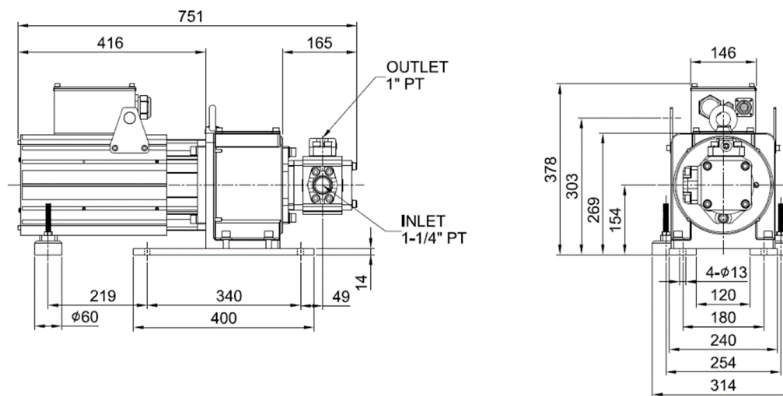

Unit: mm[inch]

2 Servo Oil Pump: HSP-040-140-43C



Component	Model Name	Quantity
Motor	MSJ-IR201EE42C	1
Oil Pump	EIPC3, 40cc/rev	1

3 Accessory Kit: HESP-100-H-NC43

Component	Model Name	Quantity
Braking Resistor	BR300W025 (MH300W)	1
Pressure Sensor		1
Anti-interference magnetic ring		1
Sensor clamp		1
casing tube head		1

NOTE: An encoder cable is included in the HSP Servo Oil Pump package.
(Model Name: CBHE-E5M)



4 Braking Resistor: BR1K0W025 (MH1000W)

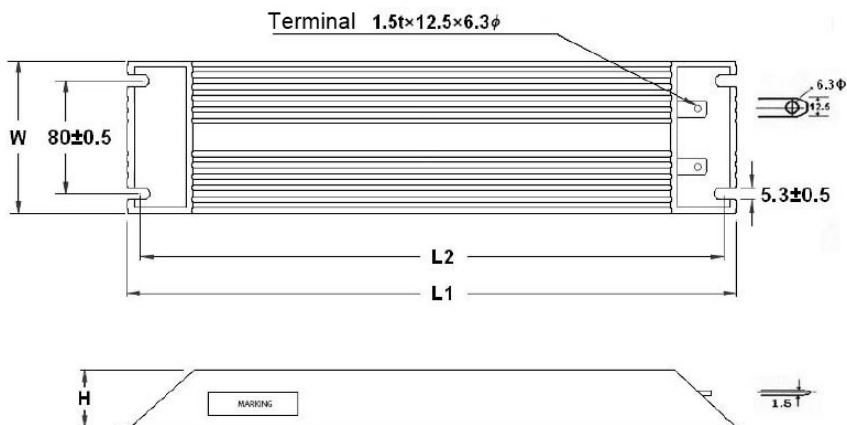

Unit: mm

TYPE	L1 ± 2	L2 ± 2	W ± 0.5	H ± 0.5
MH 1000 W	400	385	100	50

11. HES125H43C

1 servo controller: VFD220VJ43C12HC

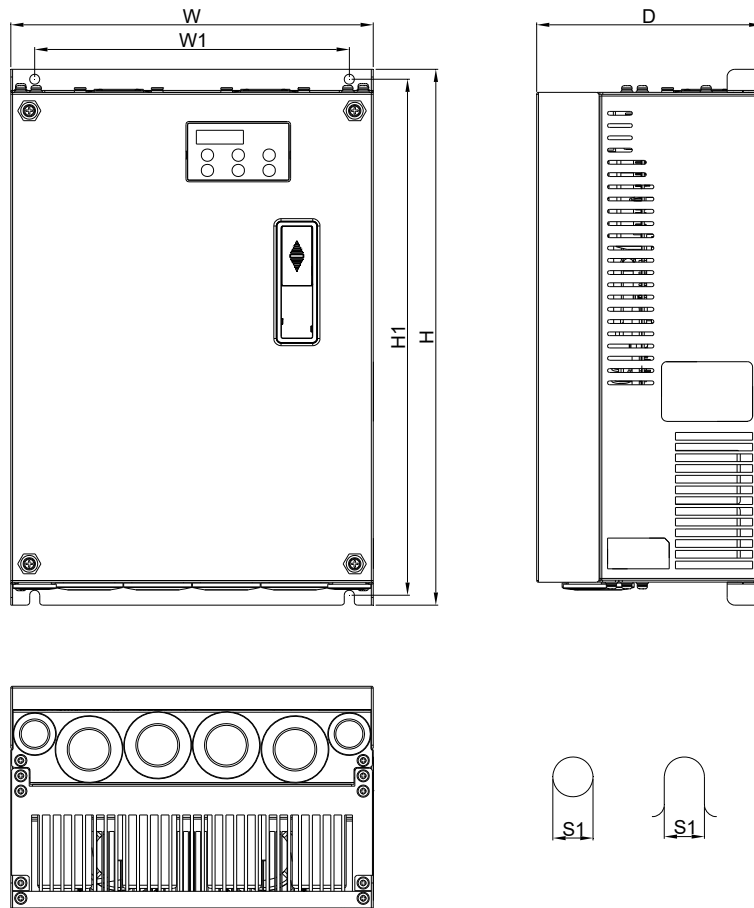

Frame	W	W1	H	H1	D	S1
C	235 [9.25]	204 [8.03]	350 [13.78]	337 [13.27]	146 [5.75]	6.5 [0.26]



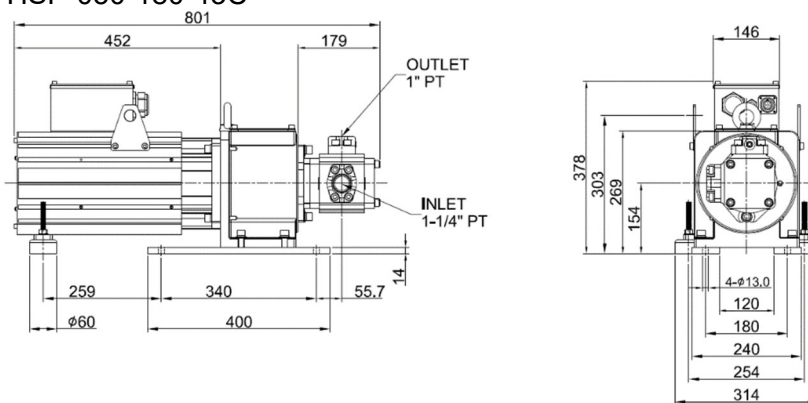

Unit: mm[inch]

2 Servo Oil Pump: HSP-050-180-43C



Component	Model Name	Quantity
Motor	MSJ-IR201IE42C	1
Oil Pump	EIPC3, 50cc/rev	1

3 Accessory Kit: HESP-125-H-NC43

Component	Model Name	Quantity
Braking Resistor	BR1K0W025 (MH1000W)	1
Pressure Sensor		1
Anti-interference magnetic ring		3
Sensor clamp		1
casing tube head		1

NOTE: An encoder cable is included in the HSP Servo Oil Pump package.
(Model Name: CBHE-E5M)



4 Braking Resistor: BR1K0W025 (MH1000W)

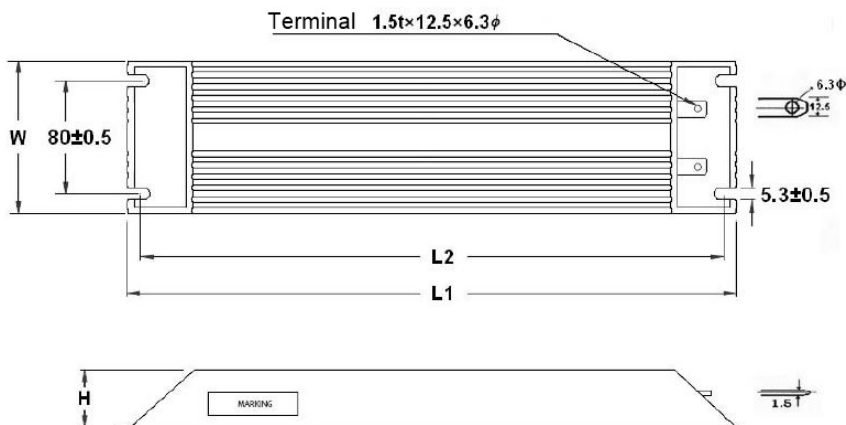

Unit: mm

TYPE	L1 ± 2	L2 ± 2	W ± 0.5	H ± 0.5
MH 1000 W	400	385	100	50

12. HES160H43C

1 servo controller: VFD300VJ43C16HC

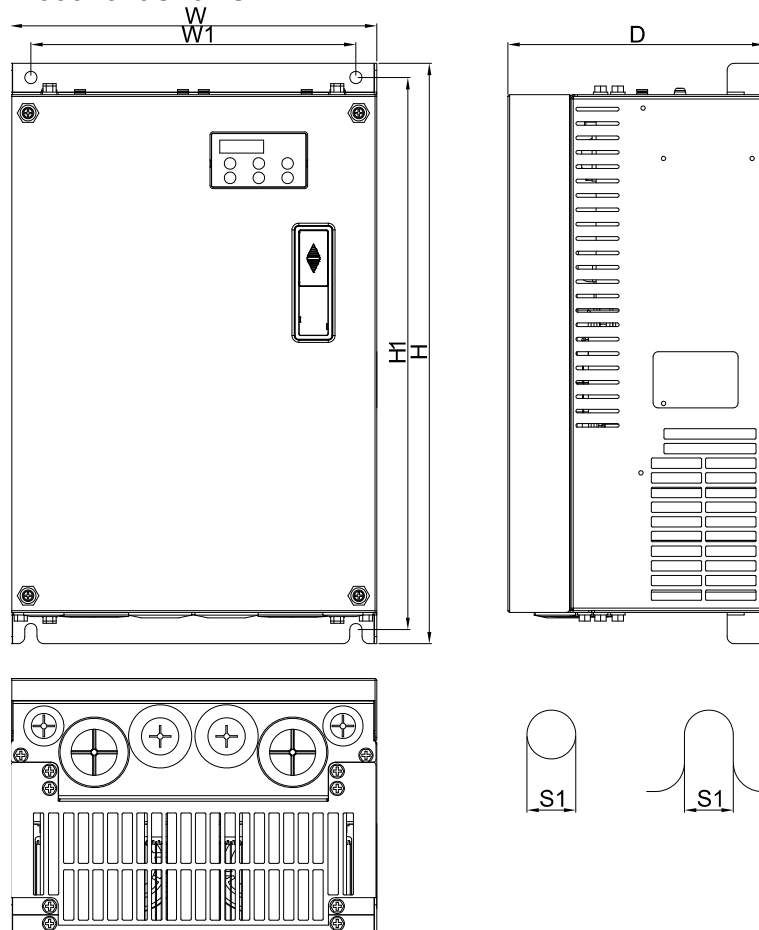

Frame		W	H	D	W1	H1	S1
D	mm	255	403.8	178.0	226.0	384	8.5
	inch	10.04	15.90	7.00	8.90	15.12	0.33

Unit: mm[inch]

2 Servo Oil Pump: HSP-064-230-43C

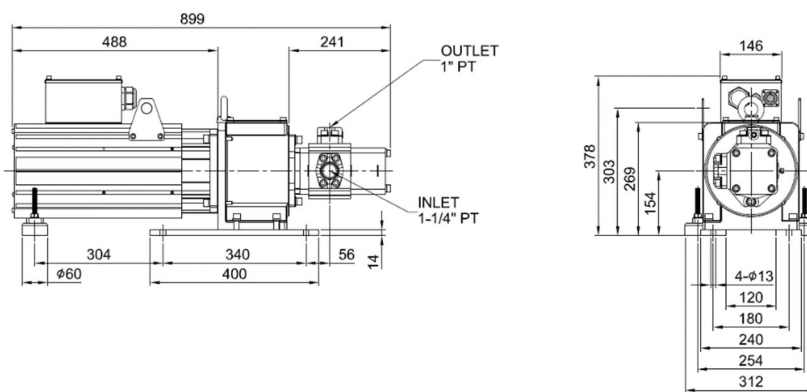

Component	Model Name	Quantity
Motor	MSJ-OR202DE42C	1
Oil Pump	EIPC3, 64cc/rev	1

3 Accessory Kit: HESP-160-H-NC43

Component	Model Name	Quantity
Braking Resistor	MHR1K0W019 (MH1000W)	1
Pressure Sensor		1
Anti-interference magnetic ring		3
Sensor clamp		1
casing tube head		1

NOTE: An encoder cable is included in the HSP Servo Oil Pump package
(Model Name: CBHE-E5M)



4 Braking Resistor: MHR1K0W019, RESISTOR 1000W

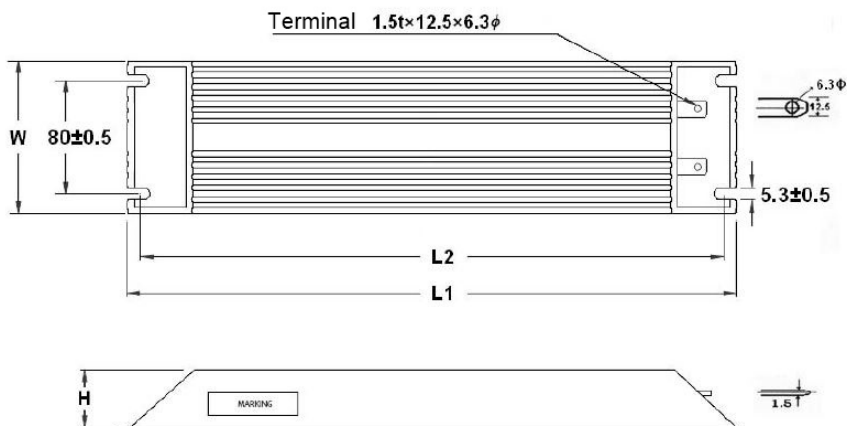

Unit: mm

TYPE	L1 ± 2	L2 ± 2	W ± 0.5	H ± 0.5
MH 1000 W	400	385	100	50

13. HES200H43C

1 servo controller: VFD300VJ43C20HC

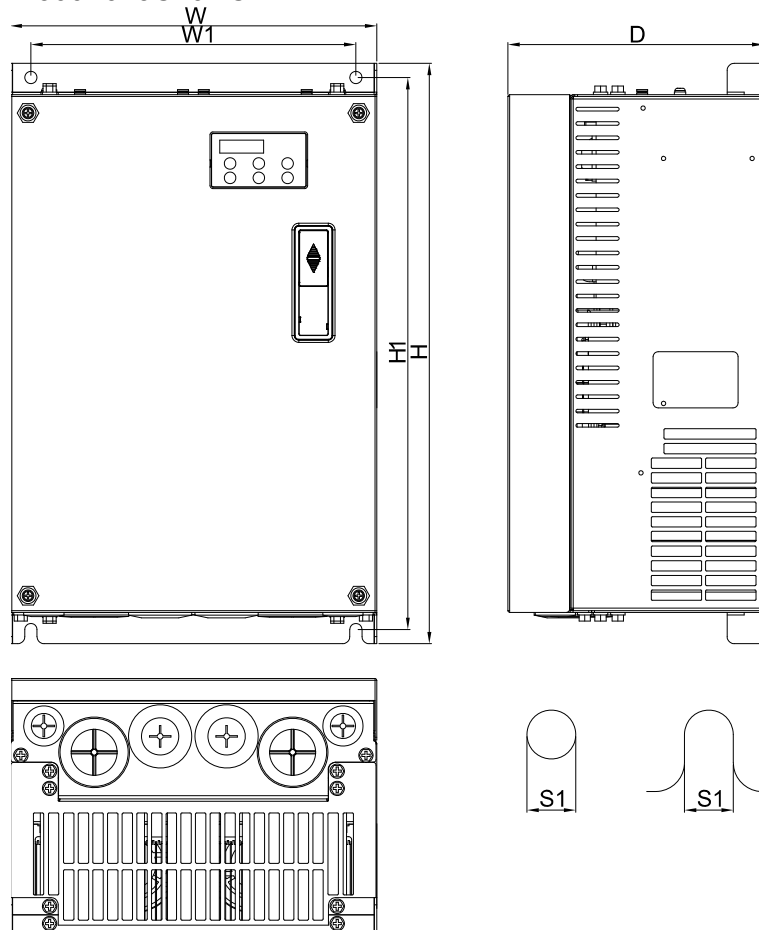

Frame		W	H	D	W1	H1	S1
D	mm	255	403.8	178.0	226.0	384	8.5
	inch	10.04	15.90	7.00	8.90	15.12	0.33

Unit: mm[inch]

2 Servo Oil Pump: HSP-080-250-43C

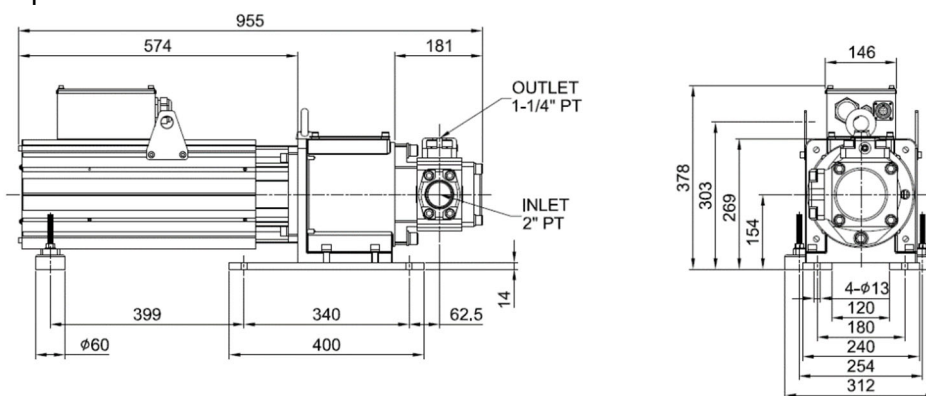

Component	Model Name	Quantity
Motor	MSJ-LR202FE42C	1
Oil Pump	EIPC5, 80cc/rev	1

3 Accessory Kit: HESP-200-H-NC43

Component	Model Name	Quantity
Braking Resistor	MHR1K0W019 (MH1000W)	1
Pressure Sensor		1
Anti-interference magnetic ring		3
Sensor clamp		1
casing tube head		1

NOTE: An encoder cable is included in the HSP Servo Oil Pump package.
(Model Name: CBHE-E5M)



4 Braking Resistor: MHR1K0W019, RESISTOR 1000W

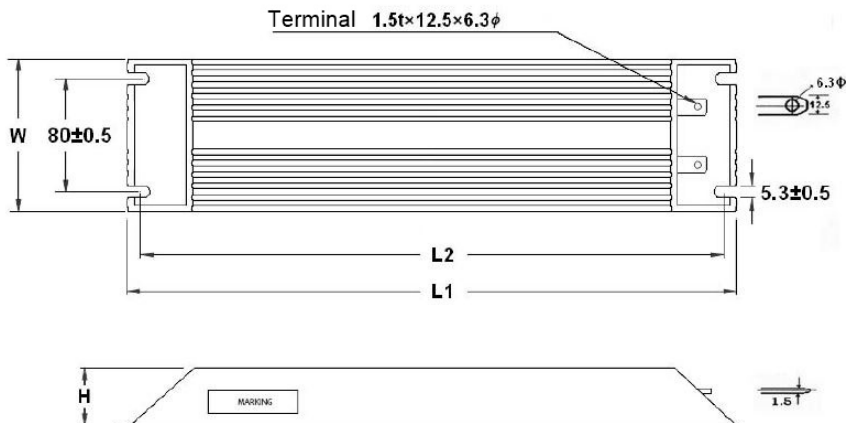

Unit: mm

TYPE	L1 ± 2	L2 ± 2	W ± 0.5	H ± 0.5
MH 1000 W	400	385	100	50

14. HES250M43C

1 servo controller: VFD550VJ43C25MC

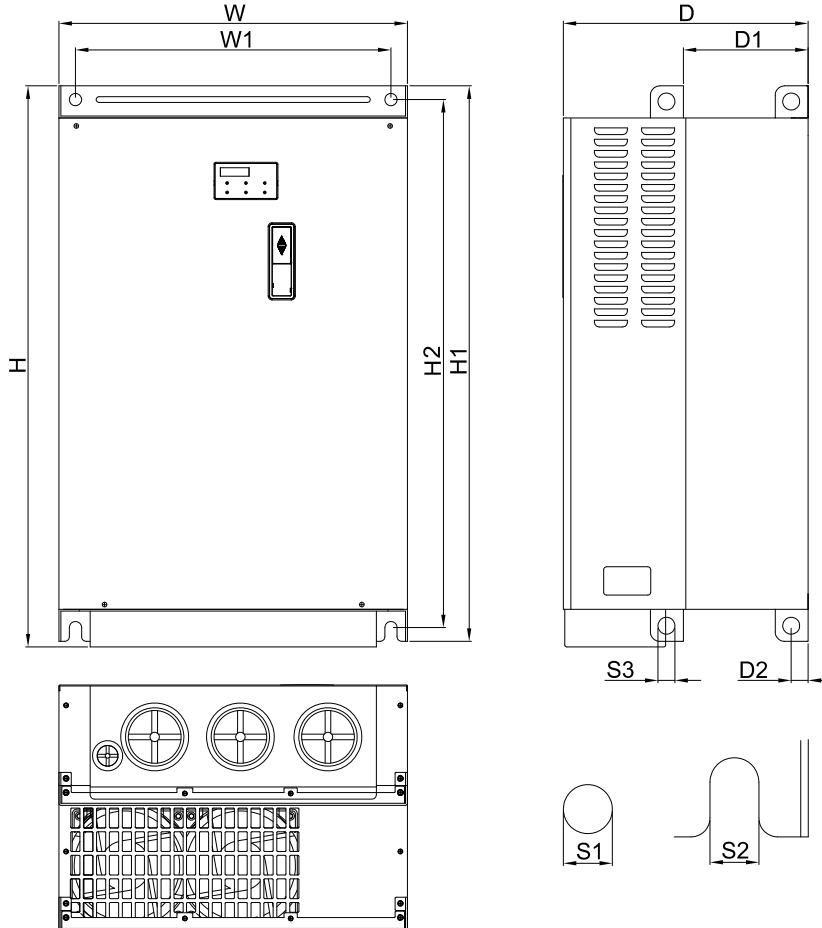

Frame		W	H	D	W1	H1	H2	D1	D2	S1	S2	S3
E2	mm	370.0	595.0	260.0	335.0	589.0	560.0	132.5	8.0	13.0	13.0	18.0
	inch	14.57	23.43	10.24	13.19	23.1	22.05	5.22	0.31	0.51	0.51	0.71

Unit: mm[inch]

2 Servo Oil Pump: HSP-125-450-43C

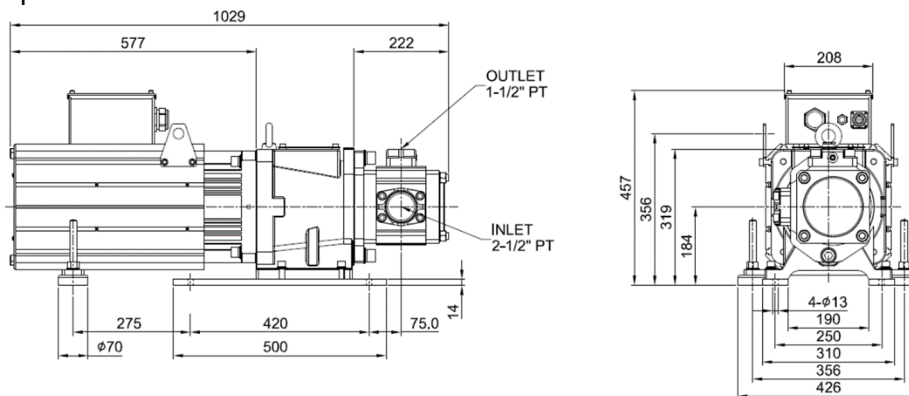

Component	Model Name	Quantity
Motor	MSJ-OR264FE48C	1
Oil Pump	EIPC6, 125cc/rev	1

3 Accessory Kit: HESP-250-M-BC43

Component	Model Name	Quantity
Braking Resistor	MHR1K5W013 (MH1500W)	1
Pressure Sensor		1
Anti-interference magnetic ring		3
Sensor clamp		1
casing tube head		1

NOTE: An encoder cable is included in the HSP Servo Oil Pump package.
(Model Name: CBHE-E5M)



4 Braking Resistor: MHR1K5W013 (MH1500W)

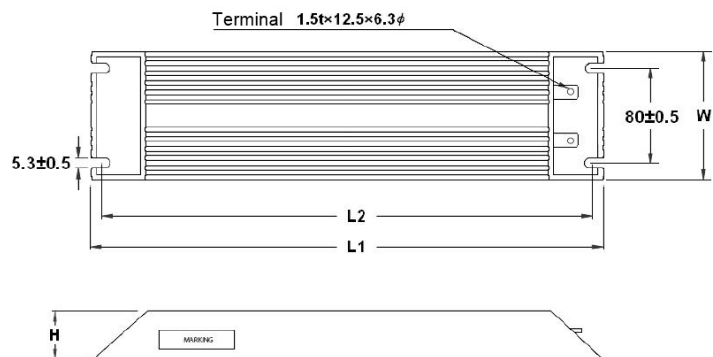

Unit: mm

TYPE	L1 ± 2	L2 ± 2	H ± 1	W ± 1
MH 1500 W	550	535	50	100

15. HES320M43C

1 servo controller: VFD550VJ43C32MC

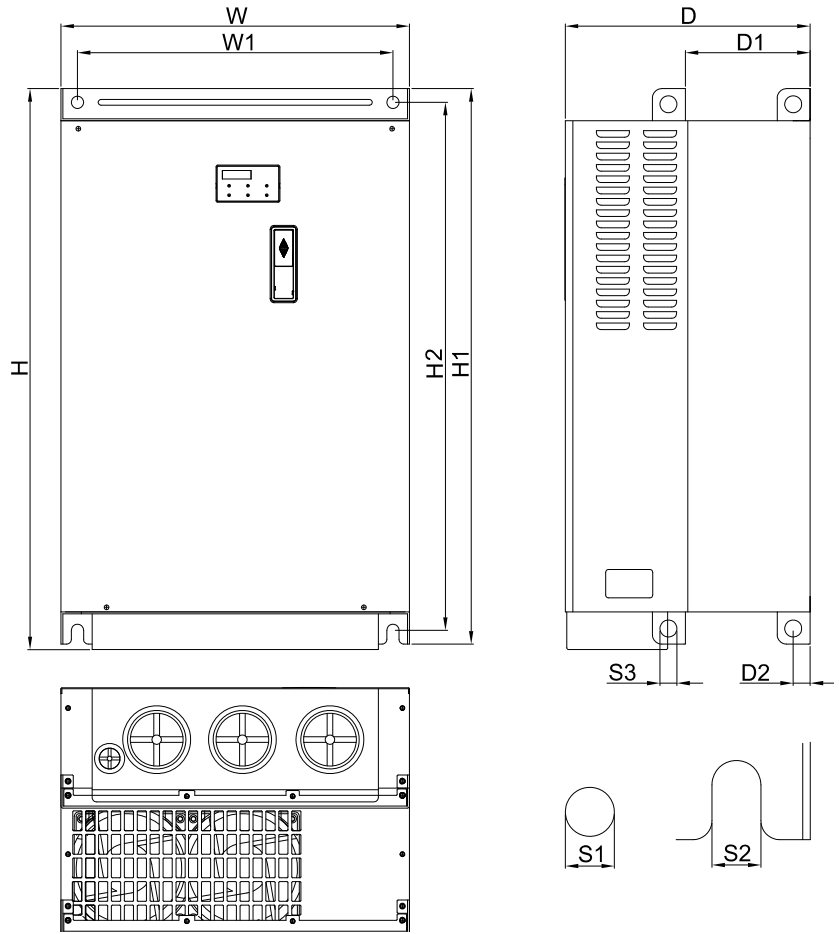

E2	mm	370.0	595.0	260.0	335.0	589.0	560.0	132.5	8.0	13.0	13.0	18.0
	inch	14.57	23.43	10.24	13.19	23.1	22.05	5.22	0.31	0.51	0.51	0.71

Unit: mm[inch]

2 Servo Oil Pump: HSP-160-520-43C

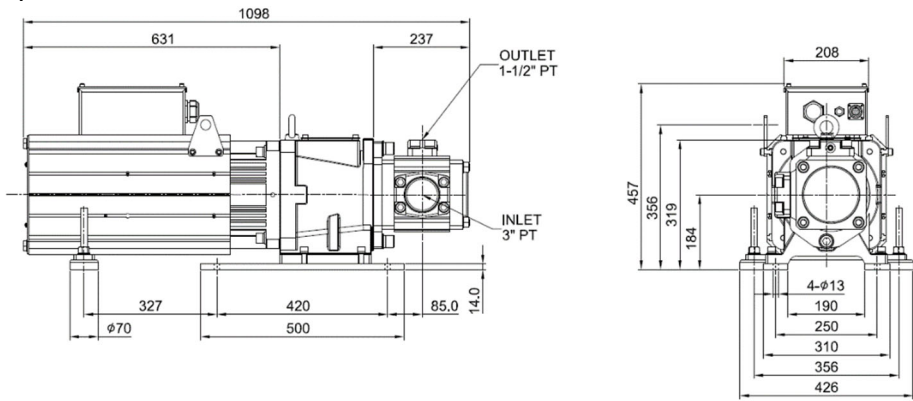

Component	Model Name	Quantity
Motor	MSJ-IR265CE48C	1
Oil Pump	EIPC6, 160cc/rev	1

3 Accessory Kit: HESP-320-M-BC43

Component	Model Name	Quantity
Braking Resistor	MHR1K5W013 (MH1500W)	1
Pressure Sensor		1
Anti-interference magnetic ring		3
Sensor clamp		1
casing tube head		1

NOTE: An encoder cable is included in the HSP Servo Oil Pump package.
(Model Name: CBHE-E10M)



4 Braking Resistor: MHR1K5W013 (MH1500W)

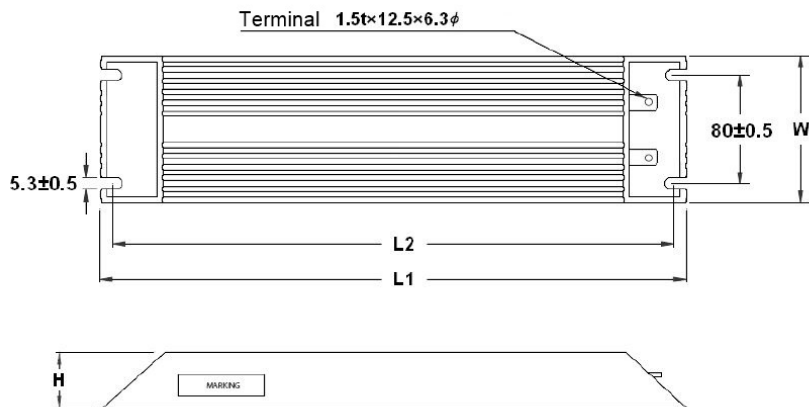

Unit: mm

TYPE	L1 ± 2	L2 ± 2	H ± 1	W ± 1
MH 1500 W	550	535	50	100

Dimensions of Servo Oil Pump for HES-C

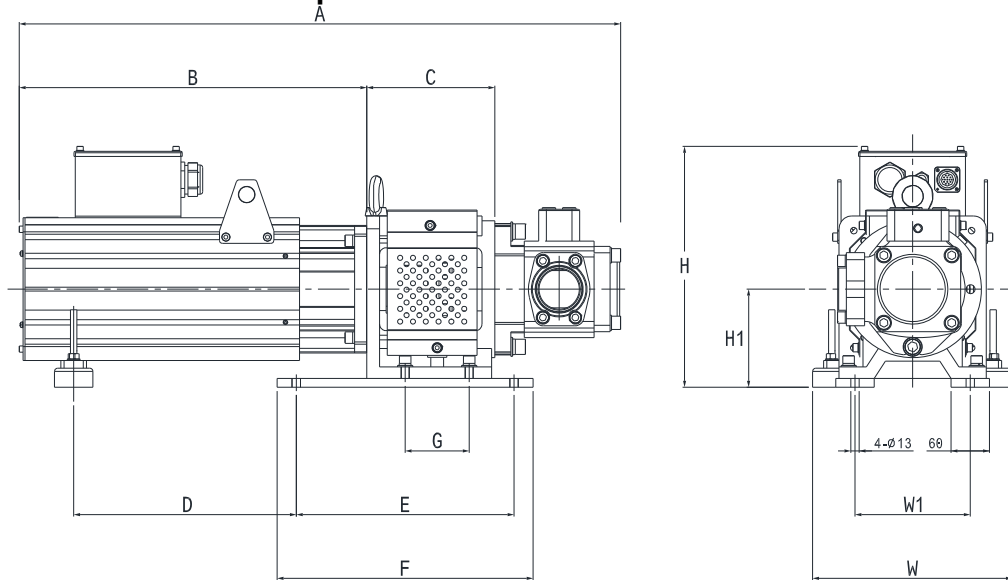

HES Model Name	A	B	C	D	E	F	G	H	H1	W	W1	Oil Inlet	Oil Outlet					
HES063H23C	695	381	170	194	340	400	95	376	154	314	180	1-1/4" PT	3/4" PT					
HES080H23C	741	417		219														
HES100H23C	752	417		219														
HES125H23C	802	453		259														
HES160H23C	859	489		304														
HES200H23C	956	575	200	399			100		154			314	2" PT	1-1/4"				
HES250G23C	972	575		399									2-1/2" PT	PT				
HES063H43C	695	381	170	194			340		400			95	376	154	314	180	1-1/4" PT	3/4" PT
HES080H43C	705	381		194														
HES100H43C	752	417		219														
HES125H43C	802	453		259														
HES160H43C	859	489		304														
HES200H43C	956	575	200	399	100	154		314		180	2" PT	1-1/4"						
											PT							
HES063M43C	705	381	170	194	340	400		95		376	154	314		180			1-1/4" PT	3/4" PT
HES080M43C	716	381		194														
HES100M43C	766	417		219														
HES125M43C	823	453		259														
HES160M43C	870	489		200			324		100				154		314	180		
HES200M43C	972	575	399				2-1/2" PT	PT										
HES250M43C	1028	577	230	275			420	500	140		458		184		426	250	2-1/2"PT	1-
HES320M43C	1098	631		327													456	3"PT

Unit: mm[inch]

Chapter 2 Wiring

2-1 Wiring

2-2 Description of Main Circuit Terminals

2-3 Description of Control Circuit Terminals

2-4 Wiring of Servo Oil Pump

Upon opening the top cover of the Hybrid Servo Controller and reveal the wiring terminal bus, check if the terminals of each Main circuit and control loop circuit are labeled clearly. Pay attention to the following wiring descriptions to avoid any incorrect connection.

- ☑ The Main circuit power terminals R/L1, S/L2, and T/L3 of the Hybrid Servo Controller are for power input. If the power supply is connected by mistake to other terminals, the Hybrid Servo Controller will be damaged. In addition, it is necessary to verify that the voltage/current rating of power supply is within the numbers listed on the name plate.
- ☑ The ground terminal must be grounded well, which can avoid being stricken by lightning or occurrence of electrocution and minimize interference by noise.
- ☑ The screw between each connection terminal and the wire must be tightened securely to avoid sparking by getting loose from vibration.



- ☑ If the wiring is to be changed, first step is to turn off the power of the Hybrid Servo Controller, for it takes time for the DC filter capacitor in the internal loop to completely discharge. To avoid any danger, the customer can wait for the charging indicator (READY light) to be off completely and measure the voltage with a DC voltmeter. Make sure the measured voltage is below the safety value of $25V_{DC}$ before starting the wiring task. If the user fails to let the Hybrid Servo Controller completely discharge, residual voltage will build up internally, which will cause short circuit and spark if wiring is conducted. Therefore, it is recommended that the user should only conduct the wiring when there is no voltage to ensure his/her safety.
 - ☑ The wiring task must be conducted only by professional personnel. Make sure that the power is off before starting to avoid incidence such as electrocution.
-



- During wiring, follow the requirements of the electrical regulations to select proper gauges and conduct wiring accordingly to ensure safety.
 - Check the following items after finishing the wiring:
 1. Are all connections correct?
 2. No loose wires?
 3. No short-circuits between terminals or to ground?
-



- ☑ The wiring for the Main circuit must be isolated from that for the control loop to avoid malfunction.
- ☑ Please use isolation wires for control wiring as much as possible. Do not expose the section where the isolation mesh is stripped before the terminal.
- ☑ Please use isolation wire or wire tube for power supply wiring and ground the isolation layer or both ends of wire tube.
- ☑ Usually the control wire does not have good insulation. If the insulation is broken for any reason, high voltage may enter the control circuit (control board) and cause circuit damage, equipment accident, and danger to operation personnel.
- ☑ Noise interferences exist between the Hybrid Servo Controller, hybrid servo motor, and their wirings. Check if the pressure sensor and associated equipments for any malfunction to avoid accidents.
- ☑ The output terminals of the Hybrid Servo Controller must be connected to the hybrid servo motor with the correct order of phases.
- ☑ When the wiring between the Hybrid Servo Controller and hybrid servo motor is very long, it may cause tripping of hybrid servo motor from over current due to large high-frequency current generated by the stray capacitance between wires. In addition, when the leakage current increases, the precision of the current value becomes poor. In such case, an AC reactor must be connected to the output side.
- ☑ The ground wire of the Hybrid Servo Controller cannot be shared with other large current load such as electric welding tool. It has to be grounded separately.
- ☑ avoid lightning strike and incidence of electrocution, the external metal ground wire for the electrical equipment must be thick and short and connected to the ground terminal of the Hybrid Servo Controller system.
- ☑ When multiple Hybrid Servo Controllers are installed together, all of them must be directly connected to a common ground terminal. Please refer to the figure below to make sure there is no ground loop.

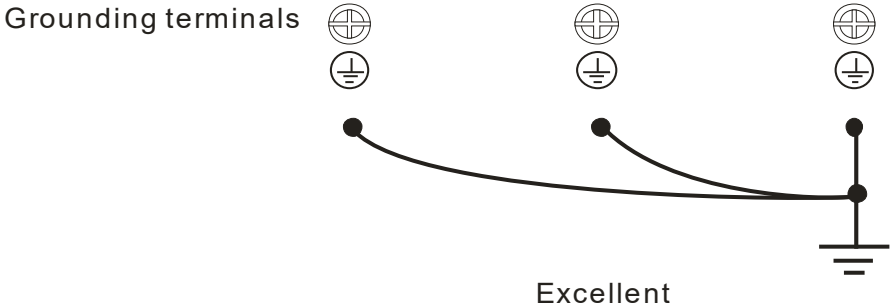

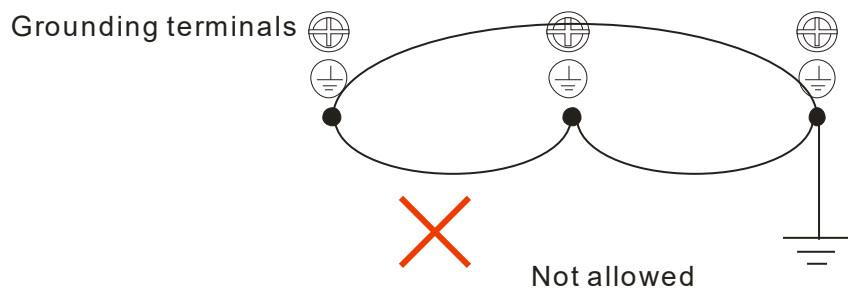
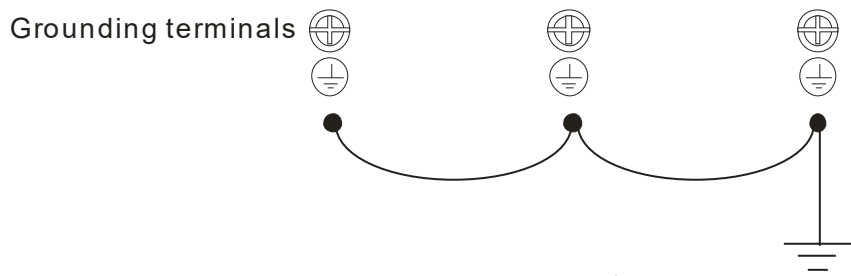

2-1 Wiring

The wiring part of the Hybrid Energy Saving System is divided into the servo oil pump and the hybrid servo controller. Follow the wiring diagrams below to wire the circuit. Install the brake resistor outside the control panel / cabinet in a place with proper ventilation. If you need to install the brake resistor inside a control panel / cabinet, you must also install some heat-conducting rubber to improve the heat dissipation. .

Applicable models to the wiring diagram:

Suitable to hybrid servo controller: VFD-VL23A__	Suitable to hybrid servo controller: VFD-__VJ43C__
Frame C: HES063H23C	Frame C: HES063H43C, HES080H43C, HES100H43C
Frame D: HES080H23C, HES100H23C, HES125H23C	Frame D: HES125H43C, HES160H43C, HES200H43C

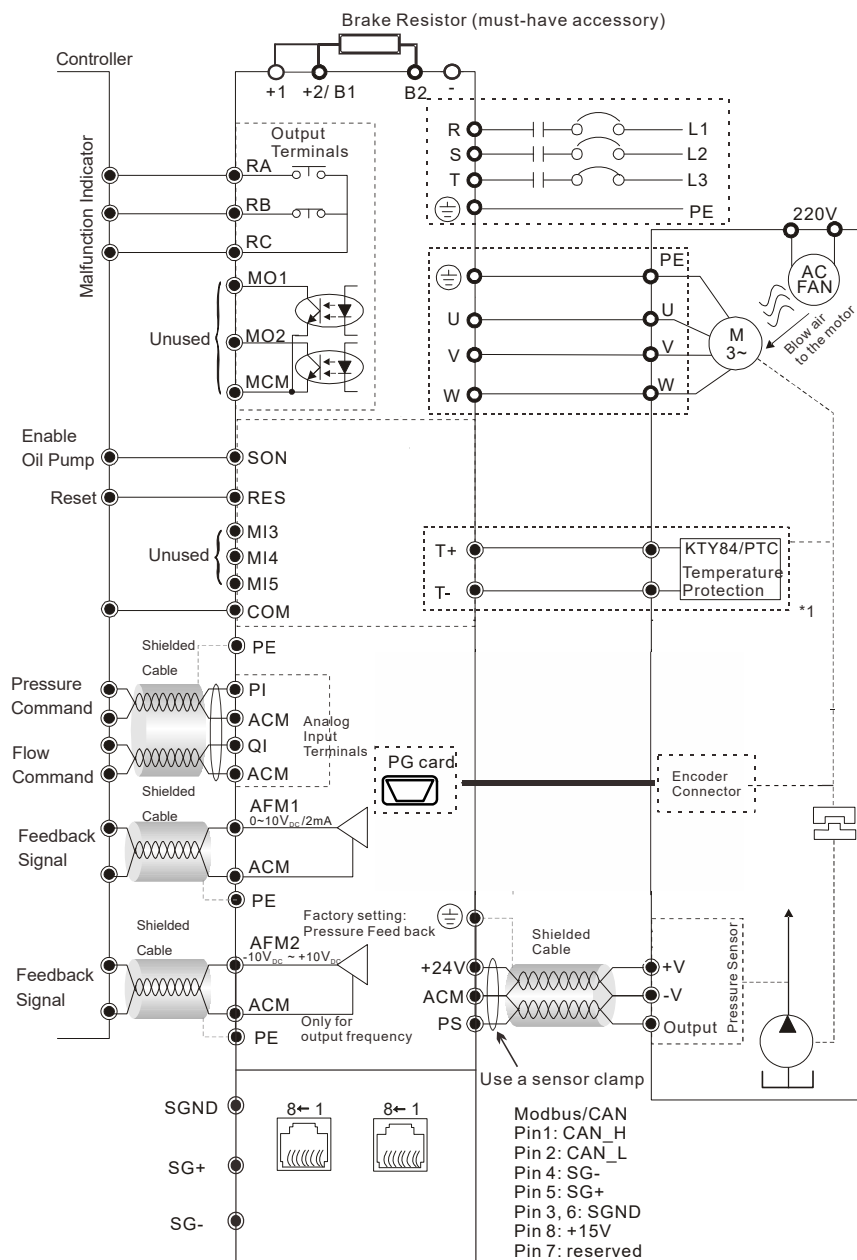

*1: Pay attention to the polarity when using KTY84. The insulation colors of the encoder cable (CBHE-E5M) are: black / white wire is KTY-, red / white wire is KTY+, yellow/black wire is PTC, and yellow wire is PTC.

Applicable models to the wiring diagram

(Suitable to hybrid servo controller: VFD-__VJ43C__ and VFD-__VJ23C__)

Frame E2: HES250M43C, HES320M43C

Frame E4: HES160H23C, HES200H23C, HES250G23C

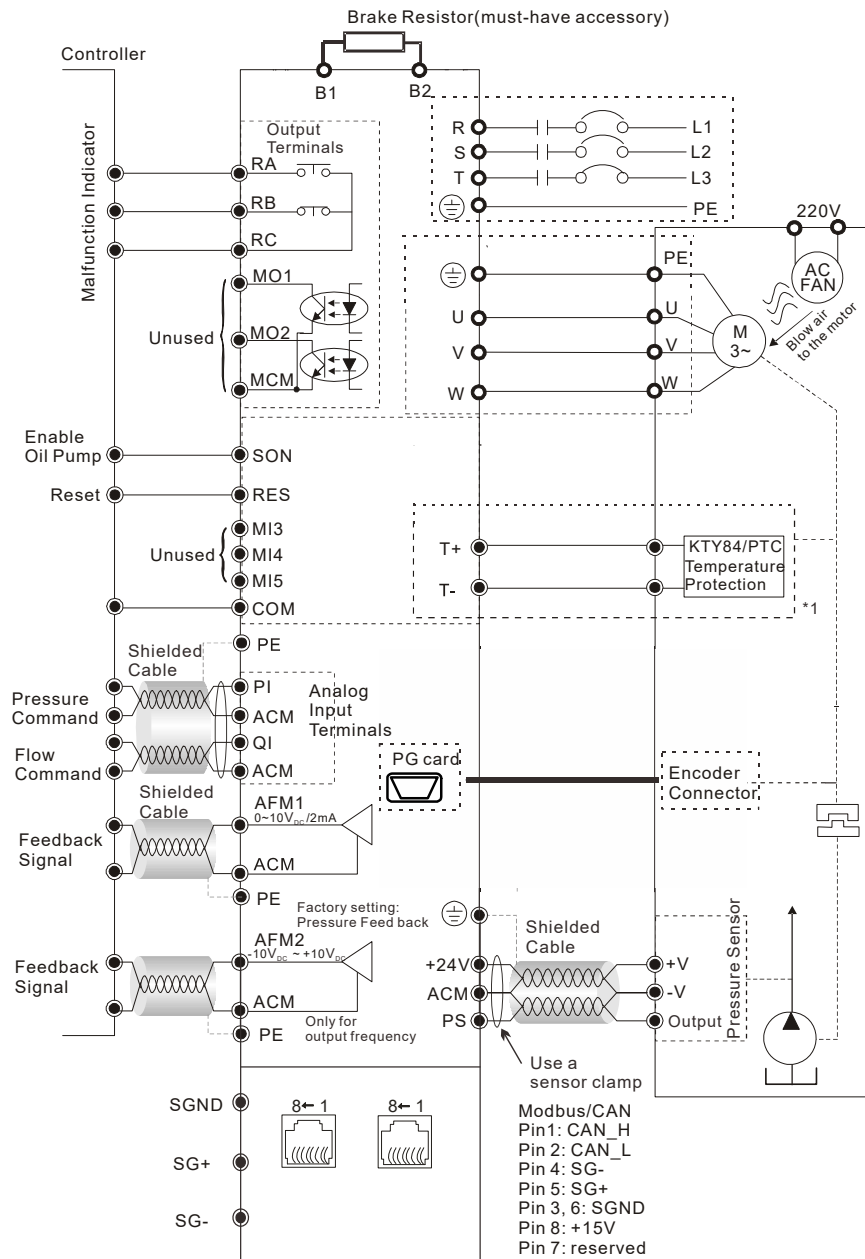

*1: Pay attention to the polarity when using KTY84. The insulation colors of the encoder cable (CBHE-E5M) are: black / white wire is KTY-, red / white wire is KTY+, yellow/black wire is PTC, and yellow wire is PTC.

For models with power rating below 22kW.
(it is recommended to wrap the output wire around the zero-phase reactor for over three times before connecting it to the motor)

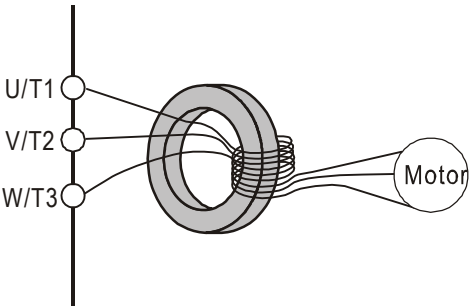

For models with power rating above 30kW.
(included) and all the models of HES 230V.series.

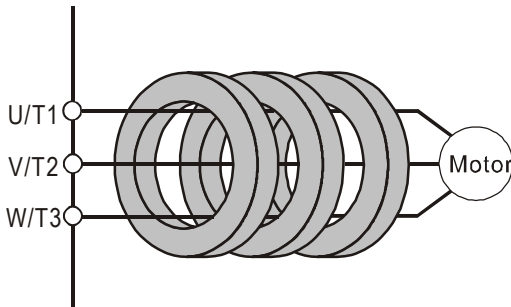

Wiring Diagram of Pressure Sensor:

Delta standard accessory: Voltage type pressure Sensor => Pin1: 24V, Pin2: ACM, Pin3: PS

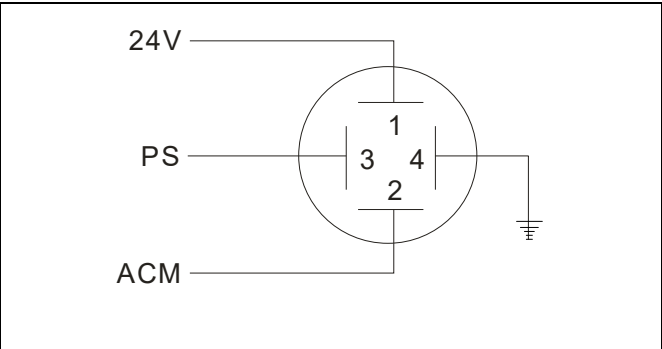

Optional accessory: Current type pressure Sensor => Pin1: 24V , Pin2: PS

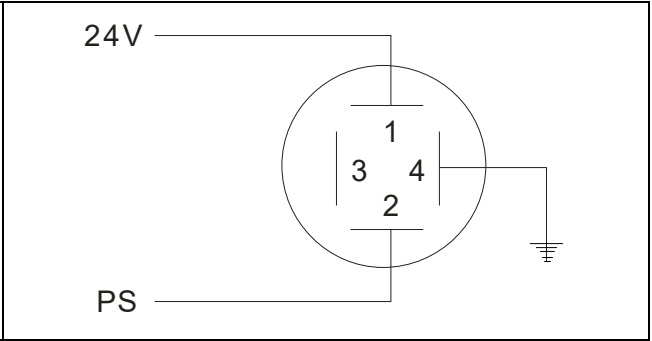

Multi-pump Operation Mode

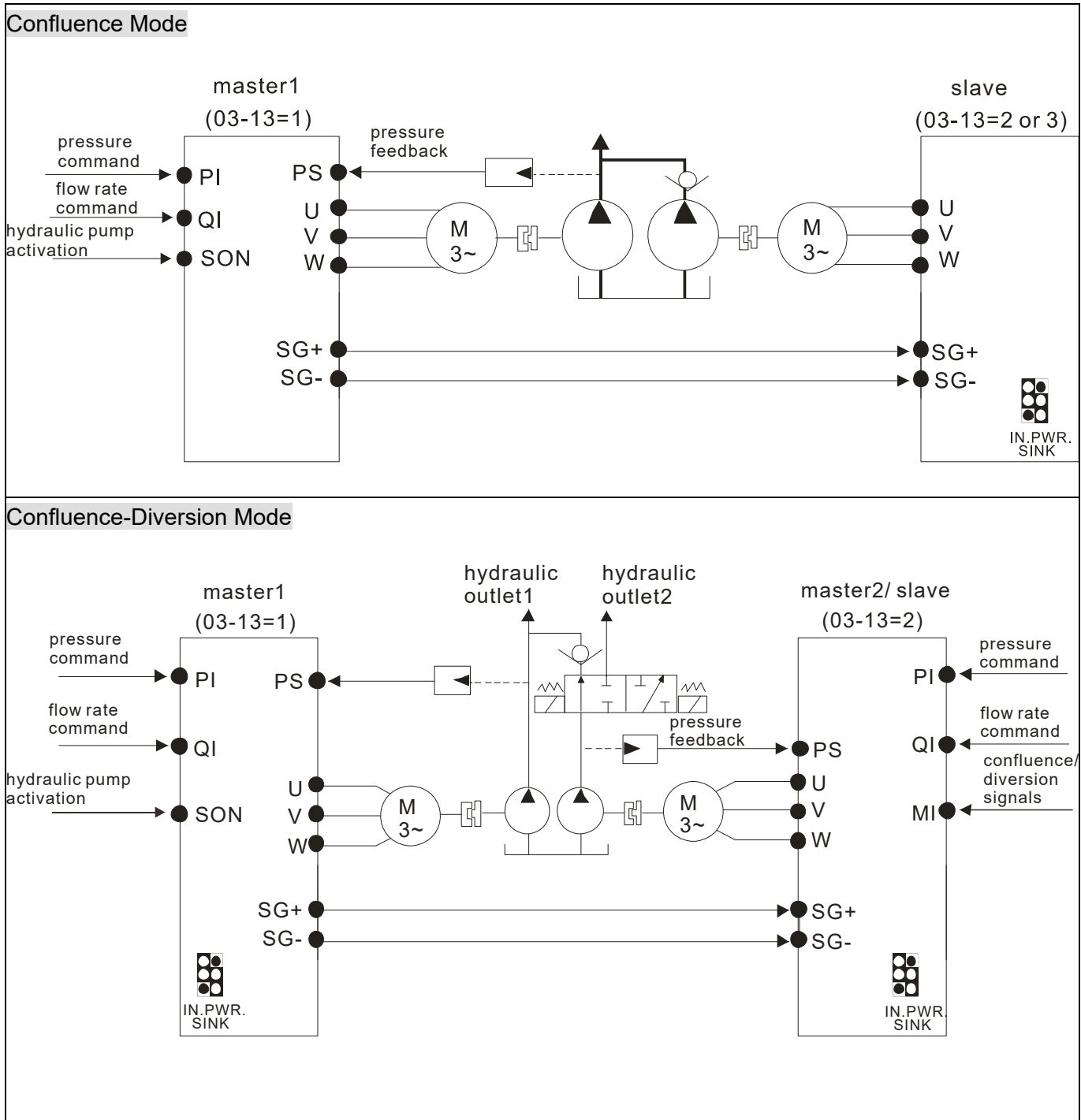

NOTE

- 1) If the slave needs to run reversely to release the pressure, do not install an one-way valve on the oil outlet end of the slave.
- 2) At confluence mode, the slave runs in speed mode. The operation command and the speed command of the slave are all sent from the master through RS485.
- 3) At the diversion mode, the two hybrid servo controllers runs in pressure mode. The run command, pressure command, and flow rate command are all sent by the master

When the signals are confluent, the communication will be a short circuit.
When the signals are diversional, the communication becomes an open circuit.

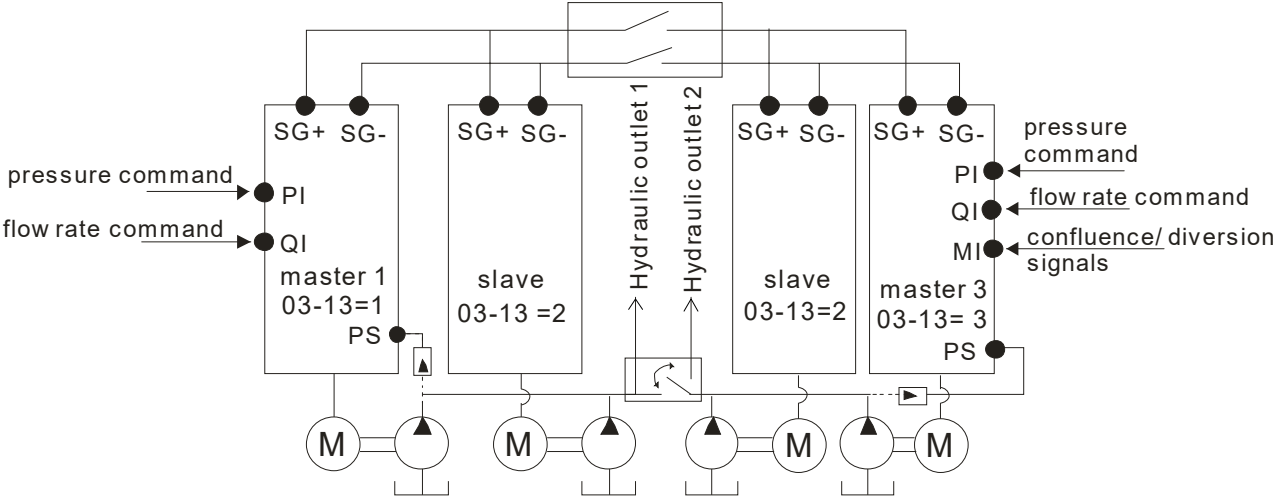

2-1-1 Grounding Short-Circuit Plate Description (RFI Switch)

RFI switch

The drive contains Varistors / MOVs that are connected from phase to phase and from phase to ground to protect the drive against mains surges or voltage spikes.

Because the Varistors/MOVs from phase to ground are connected to ground with the RFI switch, removing the RFI jumper disables the protection.

The RFI switch also connects the filter capacitors to ground from a return path for high frequency noise to isolate the noise from contaminating the mains power. Removing the RFI switch strongly reduces this protection.

Isolating main power from ground

When the power distribution system of the drive is a floating ground system (IT Systems) or a TT system (Terre-Terre en français, or earth-earth in English), you must remove the RFI switch. Removing the RFI switch disconnects the internal capacitors from ground to avoid damaging the internal circuits and to reduce the ground leakage current (in accordance with IEC61800-3 regulation). The RFI switch is shown in the images below.

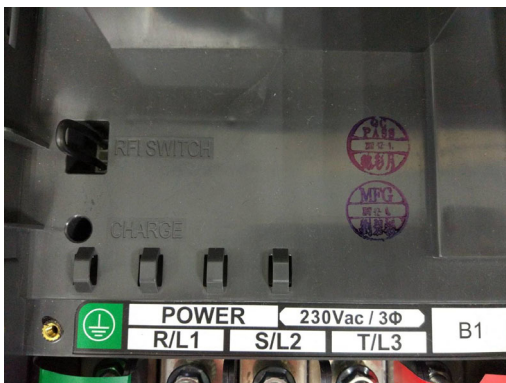





RFI Switch on the motor drive



Removable RFI Switch

NOTE

-  Do not remove the RFI switch while the power is on.
-  Efficient galvanic isolation is no longer guaranteed if removing the RFI switch. Then all the input and output terminals are low voltage terminals which have basic isolation. Removing the RFI switch also reduces the compliance with the EMC specification.
-  Do not remove the RFI switch while conducting high voltage tests. When conducting a high voltage test to the entire facility, you must disconnect the mains power and the motor if the leakage current is too high
-  Do not switch off the RFI switch when the main power is a grounded power system. To prevent motor drive damage, the RFI switch shall be removed if the motor drive is installed on an ungrounded power system, a high resistance-grounded (over 30 ohms) power system, or a corner grounded TN system.

Floating Ground System (IT Systems)

A floating ground system is also called IT system, ungrounded system, or high impedance/resistance (greater than 30Ω) grounding system.

- Disconnect the ground cable from the internal EMC filter.
- In situations where EMC is required, check whether there is excess electromagnetic radiation affecting nearby low-voltage circuits. In some situations, the adapter and cable naturally provide enough suppression. If in doubt, install an extra electrostatic shielded cable on the power supply side between the main circuit and the control terminals to increase security.

Asymmetric Ground System (Corner Grounded TN Systems)

Caution: Do not remove the RFI switch while the input terminal of the hybrid servo drive carries power. In the following four situations, the RFI switch must be removed. This is to prevent the system from grounding through the RFI capacitor and damaging the hybrid servo drive

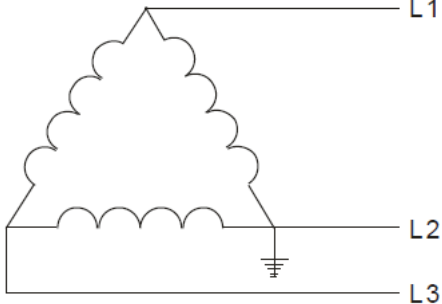
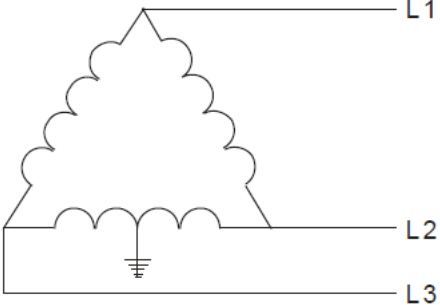
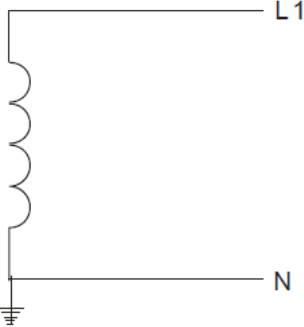
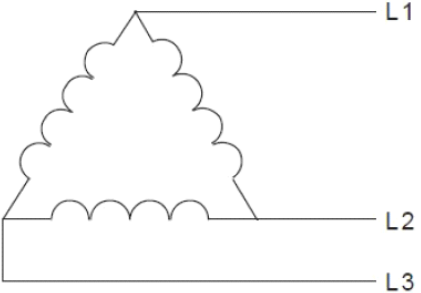
Remove the RFI switch	
<p>1. Corner-Grounded Delta System)</p> 	<p>2. Center-Tap Grounded Delta System)</p> 
<p>3. Single Phase with Ground)</p> 	<p>4. Delta System without Ground)</p> 

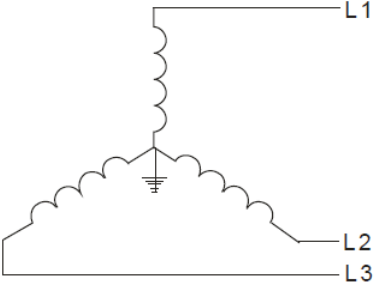
Keep the RFI switch	
<p>Internal grounding through RFI capacitor, which reduces electromagnetic radiation. In a situation with higher requirements for electromagnetic compatibility, and using a symmetrical grounding power system, an EMC filter can be installed. As a reference, the diagram on the right is a symmetrical grounding power system.</p>	<p>Y connection (Star Connection) with stable neutral grounding point.</p> 

2-2 Description of Main Circuit Terminals

Motor

Terminal Identification	Description
R/L1, S/L2, T/L3	AC line input terminals 3-phase
U/T1, V/T2, W/T3	Output terminals of the hybrid servo drive that are connected to the motor
+1, +2/B1	Terminals to connect to DC reactor to improve the power factor. Remove the RFI switch before connecting a DC reactor to a hybrid servo drive. (DC reactor is built in for models $\geq 45KW$)
+2/b1, B2	Terminals to connect to brake resistor (optional, see Appendix A-1 for more information)
	Grounding Terminal, please comply with local regulations.



Power supply input terminals for the main circuit:

- Do not connect three-phase model to one-phase power. R/L1, S/L2 and T/L3 has no phase-sequence requirement, it can be used upon random selection.
- Connect these terminals (R/L1, S/L2, T/L3) via a non-fuse breaker or an earth leakage breaker to the three-phase AC power for circuit protection. It is unnecessary to consider phase-sequence.
- It is recommend adding a magnetic contactor (MC) to the power input wiring to cut off power quickly and reduce malfunction when activating the protection function of the AC motor drive. Both ends of the MC should have an R-C surge absorber.
- Fasten the screws in the main circuit terminal to prevent sparks condition made by the loose screws due to vibration.
- Please use voltage and current within the specification. Please refer to Chapter 1 for the specifications.
- When using a general GFCI (Ground Fault Circuit Interrupter), select a current sensor with sensitivity of 200mA or above and not less than 0.1-second operation time to avoid nuisance tripping.
- Please use the shield wire or tube for the power wiring and ground the two ends of the shield wire or tube.

Output terminals for the main circuit:

- When it needs to install the filter at the output side of terminals U/T1, V/T2, W/T3 on the hybrid servo drive. Please use inductance filter. Do not use phase-compensation capacitors or L-C (Inductance-Capacitance) or R-C (Resistance-Capacitance), unless approved by Delta.
- DO NOT connect phase-compensation capacitors or surge absorbers at the output terminals of hybrid servo drives. \

The terminals of the DC reactor [+ 1, +2],

- ☑ This is the terminals used to connect the DC reactor to improve the power factor. For the factory setting, it connects the short-circuit object. Please remove this short-circuit object before connecting to the DC reactor.

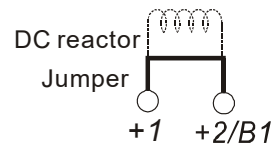

- ☑ DO NOT connect [B2] or [-] to [+2/B1] directly to prevent drive damage.

Specifications of the Main Circuit Terminals

Model Name	Mini. Wire Gauge	HSP motor screw/ nut size and torque force	Controller screw/nut size and torque force	Ring Terminal
HES063H23C	6AWG (16mm ²)	M6 25kgf-cm	M5 30kgf-cm	
HES080H23C	5AWG (25mm ²)	M6 25kgf-cm	M6 50kgf-cm	
HES100H23C	5AWG (25mm ²)	M6 25kgf-cm	M6 50kgf-cm	
HES125H23C	4AWG (25mm ²)	M6 25kgf-cm	M6 50kgf-cm	
HES160H23C	3AWG (35mm ²)	M6 25kgf-cm	M8 (nut) 150kgf-cm	
HES200H23C	2AWG (35mm ²)	M6 25kgf-cm	M8 (nut) 150kgf-cm	
HES250G23C	2AWG (35mm ²)	M6 25kgf-cm	M8 (nut) 150kgf-cm	
HES063H43C	8AWG (10mm ²)	M6 25kgf-cm	M5 30kgf-cm	
HES080H43C	8AWG (10mm ²)	M6 30kgf-cm	M5 30kgf-cm	
HES100H43C	7AWG (16mm ²)	M6 30kgf-cm	M5 30kgf-cm	
HES125H43C	6AWG (16mm ²)	M6 30kgf-cm	M6 50kgf-cm	
HES160H43C	6AWG (16mm ²)	M6 30kgf-cm	M6 50kgf-cm	
HES200H43C	5AWG (25mm ²)	M6 30kgf-cm	M6 50kgf-cm	
HES250M43C	2AWG (35mm ²)	M8 35kgf-cm	M8(nut) 150kgf-cm	The controller of these two models don't have ring terminals. But their controller have bared wires connected on them.
HES320M43C	2AWG (35mm ²)	M8 35kgf-cm	M8(nut) 150kgf-cm	

2-3 Description of Control Circuit Terminals

Description of SINK (NPN)/SOURCE (PNP) Mode Selection Terminals

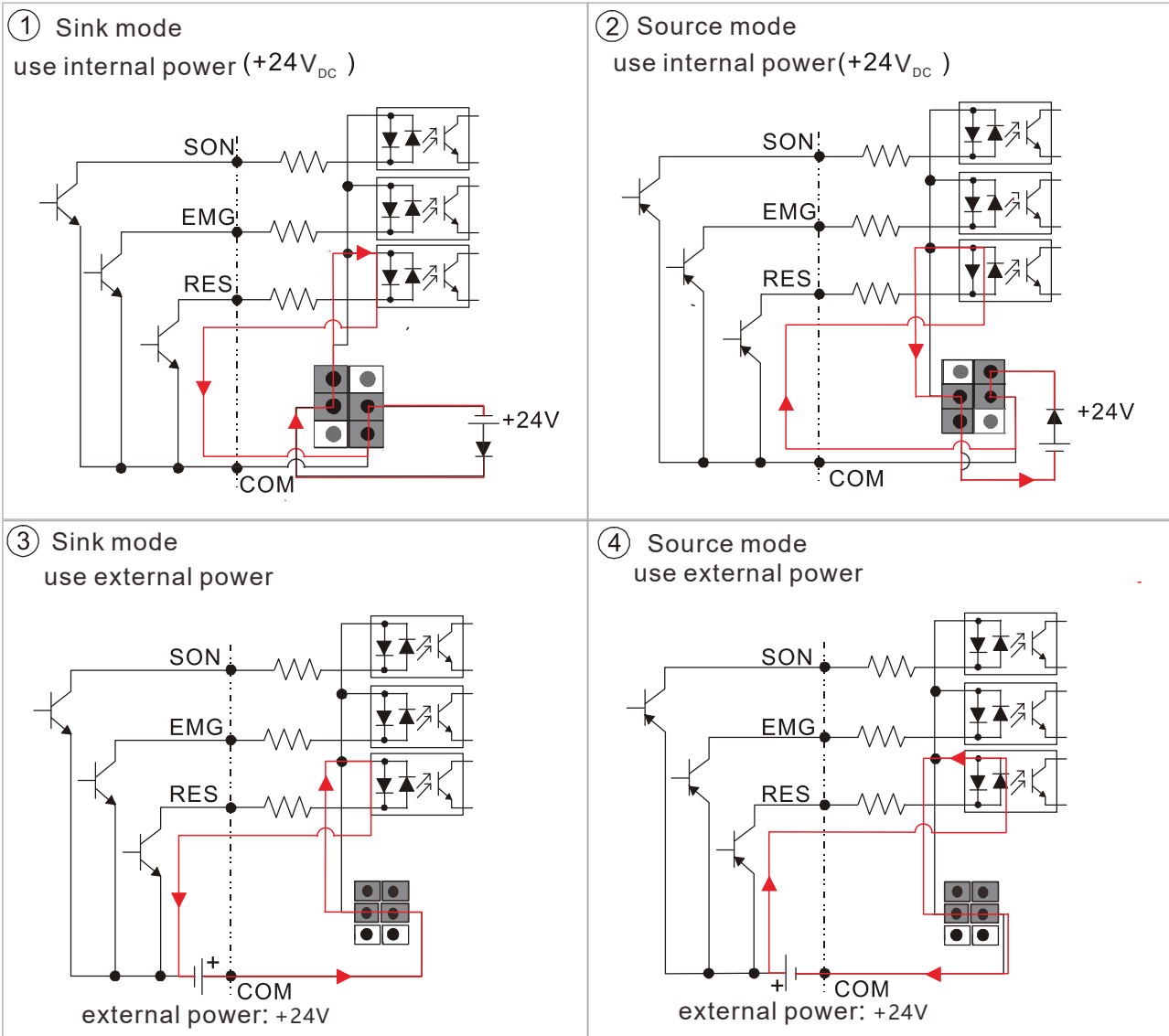

VJ-C Pluggable Wiring Terminal Blocks:

External:

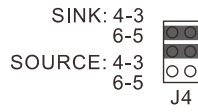

Internal:

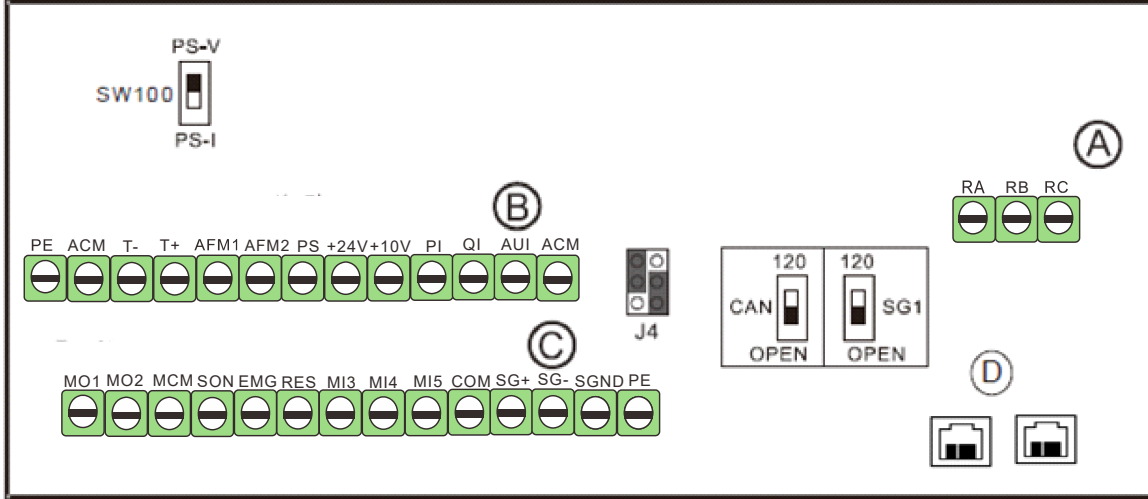
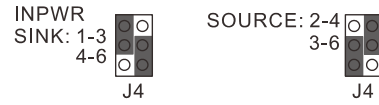

Item	Wire Gauge					Torque (±10%)
	Group	Conductor	Stripping length	Mini. Wire Gauge	Max. Wire Gauge	
Control Terminal	A	Solid	6mm	0.2mm ² [24 AWG]	1.5mm ² [16 AWG]	5kg-cm [4.4 lb-in.] [0.5 Nm]
		Stranded				
RJ-45	D					

Recommended Ring Terminals Part# and Size							
AWG	VENDOR	VENDOR P/N	A (MAX)	B (MAX)	D (MAX)	W (MAX)	
24	K.S.T	E0306	17.0mm	6.0mm	5.0mm	0.7mm	
22	K.S.T	E0506					
20	K.S.T	E7506					
18	K.S.T	E1006					
16	K.S.T	E1506					

Control Terminal	Wire Gauge					Torque (±10%)
	Group	Conductor	Stripping length	Mini. Wire Gauge	Max. Wire Gauge	
	B	Solid	7-8mm	0.2mm ² [24 AWG]	2.1mm ² [14 AWG]	2kg-cm [1.7 lb-in.] [0.2 Nm]
Stranded						
C	Solid	7-8mm	0.2mm ² [24 AWG]	2.1mm ² [14 AWG]	2kg-cm [1.7 lb-in.] [0.2 Nm]	
	Stranded					

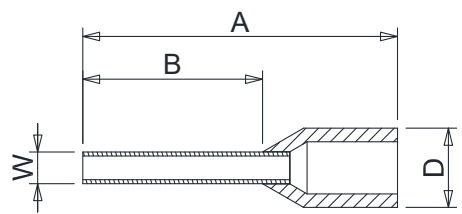
Recommended Ring Terminals Part# and Size							
AWG	VENDOR	VENDOR P/N	A (MAX)	B (MAX)	D (MAX)	W (MAX)	
24	K.S.T	E0308	17.0mm	8.0mm	4.0mm	0.7mm	
22	K.S.T	E0508					
20	K.S.T	E7508					
18	K.S.T	E1008					
16	K.S.T	E1508					
14	K.S.T	E2508					

Wiring Precautions:

For group A, B, C:

1. For group A: Tighten the wiring with a 3.5mm (width of the blade) x 0.6mm (thickness of the blade) slotted screwdriver
2. For group B, C Tighten the wiring with a 2.5mm (width of the blade) x 0.4mm (thickness of the blade) slotted screwdriver
3. When wiring bare wires, make sure they are perfectly arranged to go through the wiring holes.

NOTE:

1. As we modify the fixed terminal block to the pluggable terminal blocks, the positions of the terminals are also changed. Please verify the differences between the original and new terminal blocks before wiring.
2. The RA, RB and RC terminals are still on a fixed terminal block as before.

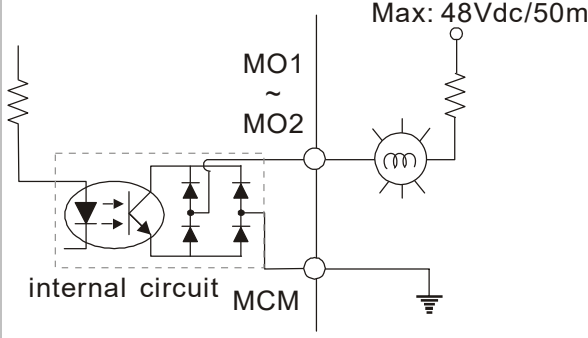
Terminal	Function	Factory Setting (NPN Mode)
SON	Run-Stop	Terminal SON-COM: ON for Running; OFF for Stop
EMG	External error input	External error input
RES	Reset from error	Reset from error
MI3	Multi-function input selection 3	Configured as no function in factory
MI4	Multi-function input selection 4	When it is ON, the input voltage is 24V _{DC} (Max: 30V _{DC}) and then input impedance is 3.75k Ω ; when it is OFF, the tolerable leakage current is 10 μ A.
MI5	Multi-function input selection 5	
COM	Common ground (Sink) for digital control signals	Common ground for multi-function input terminals
RA	Error terminal 1 (Relay N.O. a)	Resistive load 5A(N.O.)/3A(N.C.) 240V _{AC} Inductive load 1.5A(N.O.)/0.5A(N.C.) 240V _{AC} 1.5A(N.O.)/0.5A(N.C.) 24V _{DC}
RB	Error terminal 1 (Relay N.C. b)	
RC	Command contact for multi-function output terminals (Relay)	
MO1	Multi-function output terminal 1 (photocoupler)	<p>The hybrid servo drive sends various monitoring signals by means of open-collector configuration.</p> 
MO2	Multi-function output terminal 2 (photocoupler)	
MCM	Common ground for Multi-function output terminal (photocoupler)	Max 48V _{DC} 50mA
PS		<p>Pressure feedback</p> <p>Impedance: 200kΩ Resolution: 12 bits</p> <p>Range: 0 ~10V or 4~20mA = 0 ~ maximum pressure feedback value (Pr.00-08). Use SW100 switch to input current, see Pr03-12 for more information.</p>

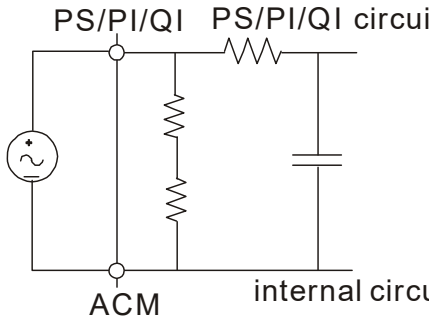
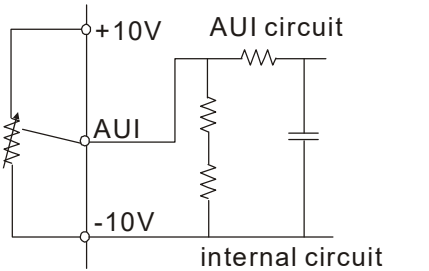
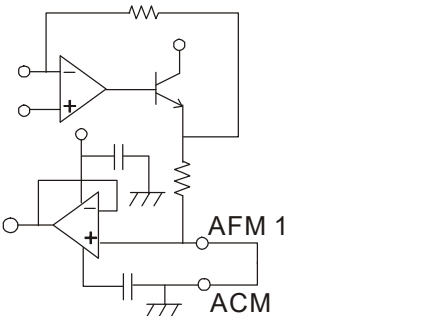
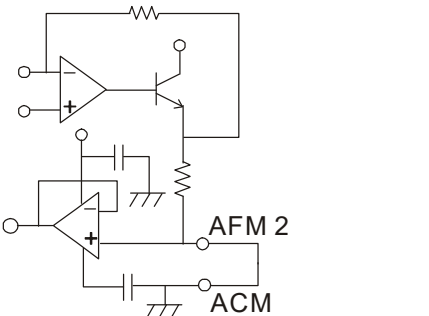
Terminal	Function	Factory Setting (NPN Mode)
PI		Pressure Command Impedance: 200kΩ Resolution: 12 bits Range: 0 ~ 10V = 0 ~ the maximum pressure command value (Pr.00-07)
QI		Flow rate command Impedance: 200kΩ Resolution: 12 bits Range: 0 ~ 10V = 0 ~ the maximum flow rate
AUI	Analog Voltage 	Impedance: 11.3kΩ Resolution: 12 bits Range: -10 ~ +10V _{DC}
+10V	Power supply for configuration	Power supply for analog configuration +10V _{DC} 20mA
+24V	Power supply terminal for the pressure sensor	Power supply for the pressure sensor +24V _{DC} 100mA
AFM1		Impedance: 19.2kΩ (voltage output) Output current: 20mA max Resolution: 0 ~ 10V corresponding to the pressure feedback. Range: 0 ~ 10V
AFM2		Impedance: 33.8kΩ (voltage output) Output current: 20mA max Resolution: ±10V corresponding to the maximum frequency Range -10~10V
ACM	Common ground for analog control signals	Common ground terminal for analog control signals
T+/ T-	Motor's thermal protection terminals	Support KTY84-130, PTC130 thermal switch
SG+, SG-, SGND	Modbus RS-485	See Communication Parameters in Ch04 for more information.
PE	protective grounding terminal	

Analog Input Terminals (PS, PI, QI, AUI, ACM)

- ☑ Analog input signals are easily affected by external noise. Use shielded wiring and keep it as short as possible (<20m) with proper grounding. If the noise is inductive, connecting the shield to terminal ACM can bring improvement.
- ☑ If the analog input signals (pressure sensor) are affected by noise from the hybrid servo drive, please connect a capacitor and ferrite core closed to the hybrid servo drive as indicated in the following diagrams. The magnetic permeability of the ferrite core should be over 5000 μ to ensure an efficient noise isolation.

Wind each wires 3 times or more around the core

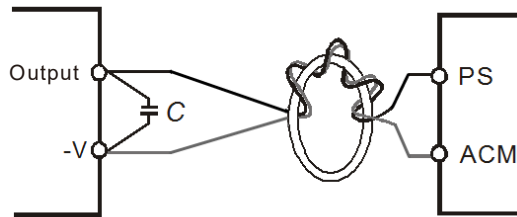

Transistor Output Terminals (MO1, MO2, MCM)

- ☑ Make sure to connect the digital outputs to the right polarity.
- ☑ When connecting a relay to the digital outputs connect a surge absorber across the coil and check the polarity.

2-4 Wiring of Servo Oil Pump

HES ____ C servo oil pump:

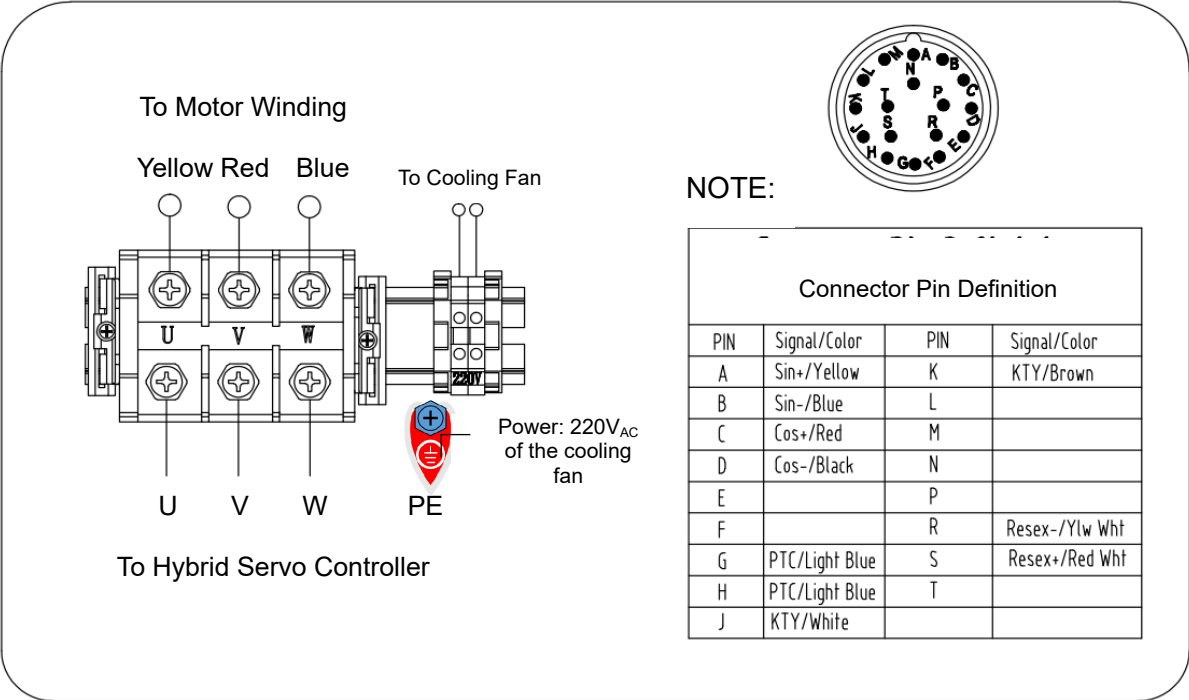
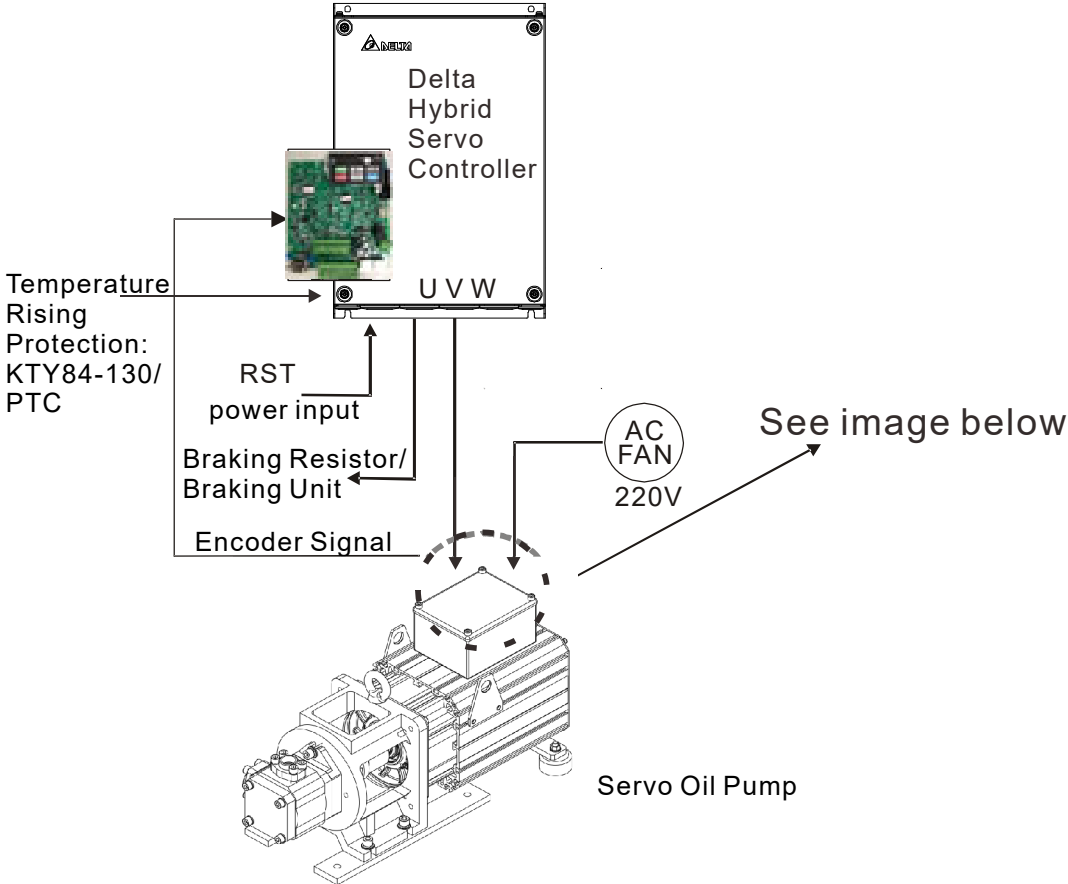

NOTE:

1. The motor temperature protection KTY84-130 signal has been integrated into the encoder cable. The PTC type temperature rising protection is added to the production after T1744/ W1744.
2. We plan to change the terminal block of the MSJ hybrid servo motor from 4-PIN to 3-PIN after Q1 of 2020 Q1. The size of the single PIN remains the same.

5-m Encoder Cable (CBHE-E5M: Delta 10-digit part# 3865345000)

220V & 380V:

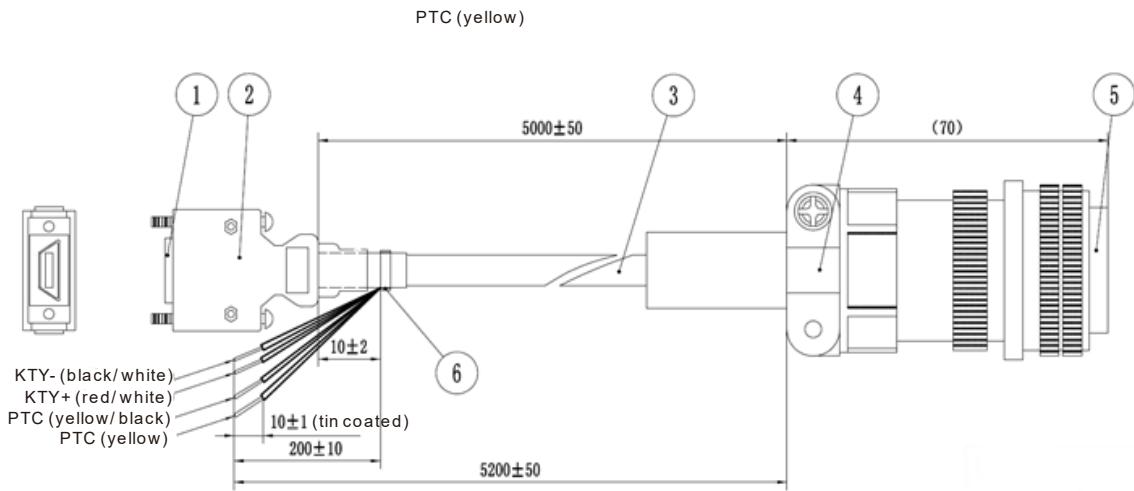

10-m Encoder Cable (Applicable for HSP-100-270-23C (HES250G23C), HSP-160-520-43C (HES320M43C))

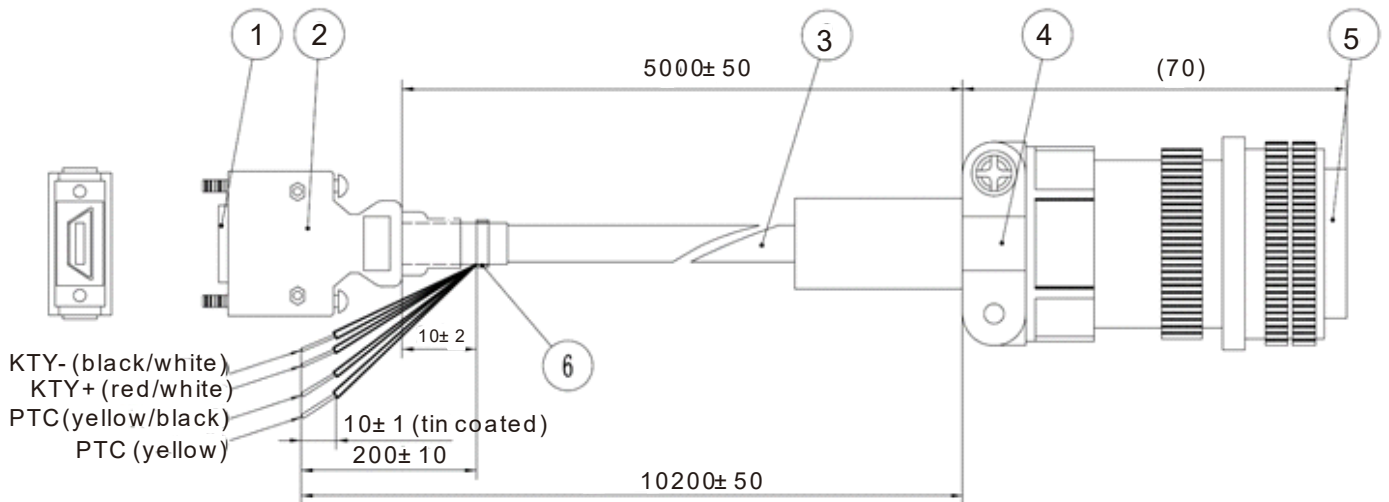

1	SCSI(MDR) Plug <Driver Side>
2	SCSI (MDR) Shell
3	Cable
4	Strain Relief
5	Military Grade Connector <Motor Side>
6	Cable Tie

The colors mentioned in the Connector Pin Definition table are only the colors of wires inside the motor. They are not the colors of the wires in the encoder cable.

Specification of a Motor’s 3-Pin Terminal Block

Voltage	220V		Screw size.	P	W	Torque Force
Frame Size	HES model name	MSJ model nme	mm	mm	mm	Nm
200	HES063H23C	MSJ-DR201AE42C	M6	19	16.7	4
	HES080H23C HES100H23C	MSJ-DR201EE42C				
	HES125H23C	MSJ-DR201IE42C				
	HES160H23C	MSJ-GR202DE42C				
	HES200H23C HES250G23C	MSJ-DR202HE42C				

Voltage	380V		Screw size.	P	W	Torque Force
Frame Size	HES model name	MSJ model nme	mm	mm	mm	Nm
200	HES063H43C HES080H43C	MSJ-IR201AE42C	M6	19	16.7	4
	HES100H43C	MSJ-IR201EE42C				
	HES125H43C	MSJ-IR201IE42C				
	HES160H43C	MSJ-OR202DE42C				
	HES200H43C	MSJ-LR202FE42C				
264	HES250M43C	MSJ-OR264FE48C	M8	25	22.5	8
	HES320M43C	MSJ-IR265CE48C		27	24	

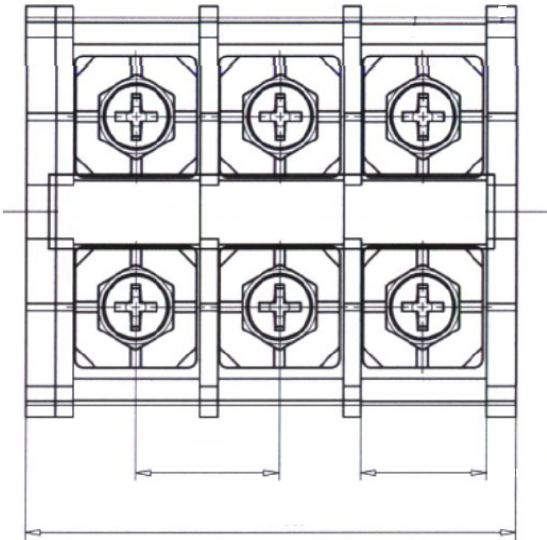

A 3-Pin Terminal Block

Recommended Specification of Power Cables for Motors

Model Name	HESxxxx23C						
	063H	080H	100H	125H	160H	200H	205G
	HSP- xxxxxxx-23C						
	025-100	032-140	040-140	050-180	064-230	080-270	100-270
Mini. Wire Gauge	6 AWG	5 AWG	5 AWG	4 AWG	3 AWG	2 AWG	2 AWG
	13.5mm ²	17mm ²	17mm ²	21mm ²	27mm ²	35mm ²	35mm ²
Distance between the center of two screws	19mm						
NOTE: Select copper wire with temperature resistance of 90°C							

Model Name	HESxxxx43C							
	063H	080H	100H	125H	160H	200H	250M	320M
	HSP- xxxxxxx-43C							
	025-100	032-100	040-140	050-180	064-230	080-250	125-450	160-520
Mini. Wire Gauge	8 AWG	8 AWG	7 AWG	6 AWG	6 AWG	5 AWG	2 AWG	2 AWG
	8.5mm ²	8.5mm ²	10.5mm ²	13.5mm ²	13.5mm ²	17mm ²	35mm ²	35mm ²
Distance between the center of two screws	19mm						25mm	27mm
NOTE: Select copper wire with temperature resistance of 90°C								

External Wiring of the Hybrid Servo Controller

Items	Explanations
Power supply	Please follow the specific power supply requirements shown in Chapter 01.
Fuse/NFB	There may be an inrush current during power up. Please check the chart of Appendix A-2 and select the correct fuse with rated current. Use of a NFB is optional.
Magnetic contactor	Do not use a Magnetic Contactor as the I/O switch of the hybrid servo controller, as it will reduce the operating life cycle of the controller. If you still need to run / stop the hybrid servo drive by switching ON/ OFF the magnetic contactor, you can do so only ONCE per hour.
Input AC Line Reactor	Used to improve the input power factor, to reduce harmonics and provide protection from AC line disturbances-(surges, switching spikes, short interruptions, etc.). AC line reactor should be installed when the power supply capacity is 500kVA or more and exceeds 6 times the inverter capacity, or the mains wiring distance $\leq 10\text{m}$. We suggest to install the input reactor close to the hybrid motor drive. See Appendix A for more details.
Zero-phase Reactor (Ferrite Core Common Choke)	Zero phase reactors are used to reduce radio noise especially when audio equipment is installed near the inverter. Effective for noise reduction on both the input and output sides. Attenuation quality is good for a wide range from AM band to 10MHz. Appendix A specifies the zero phase reactor. (RF220X00A)
EMI filter	To reduce electromagnetic interference, please refer to Appendix A for more details.
Brake Resistor	Used to reduce the deceleration time of the motor. Please refer to the chart in Appendix A for specific Brake Resistors.
Output AC Line Reactor	Motor surge voltage amplitude depends on motor cable length. For applications with long motor cable (>20m), it is necessary to install a reactor at the inverter output side.

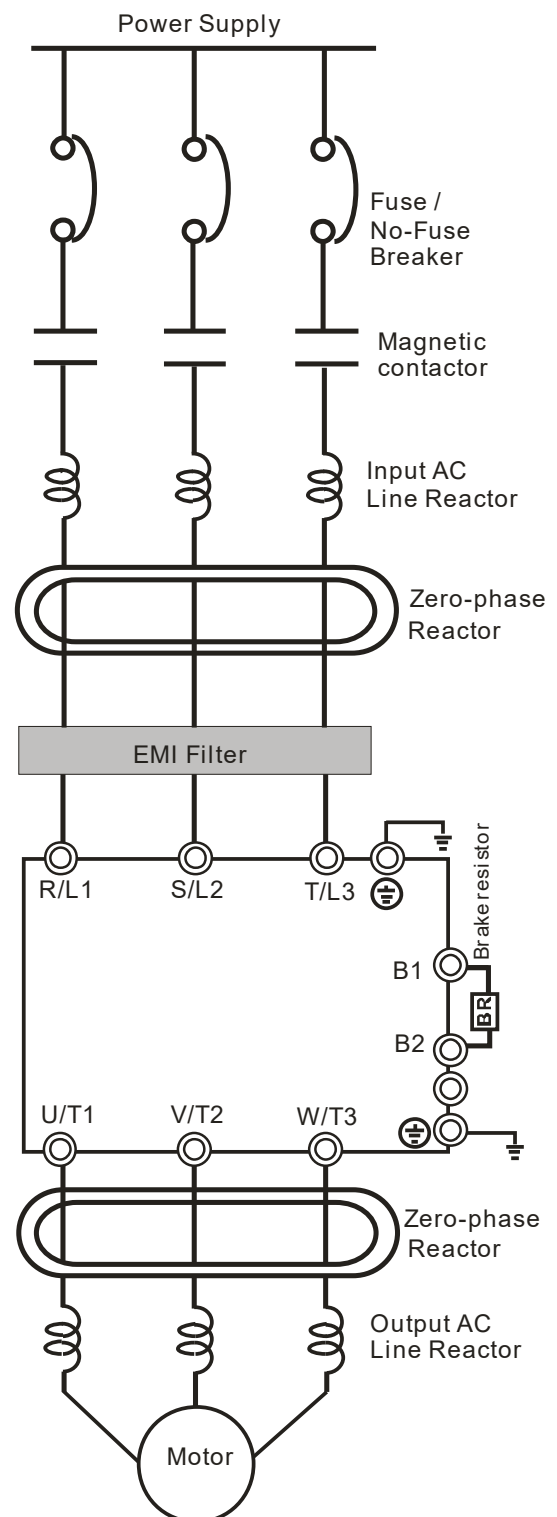

Chapter 3 Machine Adjustment Procedure

- 3-1 Description of Control Panel
- 3-2 System Setup and Machine Adjustment Flowcharts
- 3-3 Machine Adjustment Procedure
- 3-4 Confluence Machine Tuning Procedure
- 3-5 Confluence / Diversion Mode Adjustment Procedure



- ☑ Please verify again before operation that the wiring is done correctly, especially that the output terminals U/T1, V/T2, and W/T3 of the Hybrid Servo Controller cannot have any power input. Make sure that the ground terminal ⊕ is connected correctly.
- ☑ Do NOT operate the AC motor drive with humid hands.
- ☑ Check for loose terminals, connectors or screws.
- ☑ Make sure that the front cover is well installed before applying power.



- ☑ In case of abnormal operation of the Hybrid Servo Controller and the associated servo motor, stop the operation immediately and refer to “Troubleshooting” to check the causes of anomalies. After the output of the Hybrid Servo Controller is stopped, when the power terminals L1/R, L2/S, and L3/T of the main circuit are still connected, touching the output terminals U/T1, V/T2, and W/T3 of the Hybrid Servo Controller may lead to electric shock.

3-1 Description of Control Panel

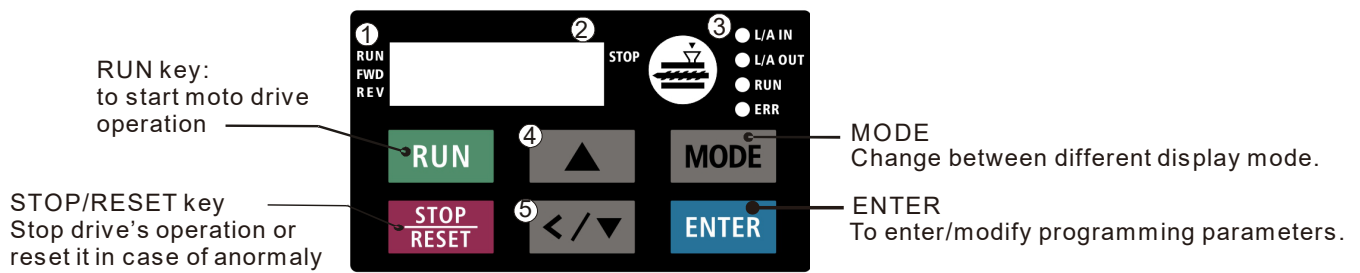

Description of the Digital Keypad KPVJ-LE02



- ① Status display
Display driv's current status
- ② LED display
Indicate frequency, voltage, current, user defined units and etc..
- ③ CANopen indicator light
- ④ UP key
Set the parameter value and change the numeric data such as frequency.
- ⑤ Left/ Down key
Set the parameter value and change the numeric data.
Press and hold the MODE key then you can use the Left key.

Description of Displayed Function Items

Displayed Item	Description
RUN ● FWD ● REV ● F6000 ● STOP	The current frequency set for the hybrid servo drive
RUN ● FWD ● REV ● H5000 ● STOP	The frequency delivered by hybrid servo drive to the motor
RUN ● FWD ● REV ● 6 1200 ● STOP	The user-defined physical quantity (Pr. 00-04)
RUN ● FWD ● REV ● A 500 ● STOP	Load current
RUN ● FWD ● REV ● Fwd ● STOP	Forward command
RUN ● FWD ● REV ● rEv ● STOP	Reverse command
RUN ● FWD ● REV ● 01-00 ● STOP	Displays the selected parameter
RUN ● FWD ● REV ● 10 ● STOP	Display the parameter value
RUN ● FWD ● REV ● EF ● STOP	Display the external fault

	<p>If the “End” message (as shown in the left figure) is displayed on the display area for about one second, it means that data has been accepted and automatically stored in the internal memory</p>
	<p>If the setting data is not accepted or its value exceeds the allowed range, this error message will be displayed</p>

Keypad Panel Operation Procedure:

A. Selecting Mode



Note: In the selection mode, press  to set the parameters

Setting Parameters

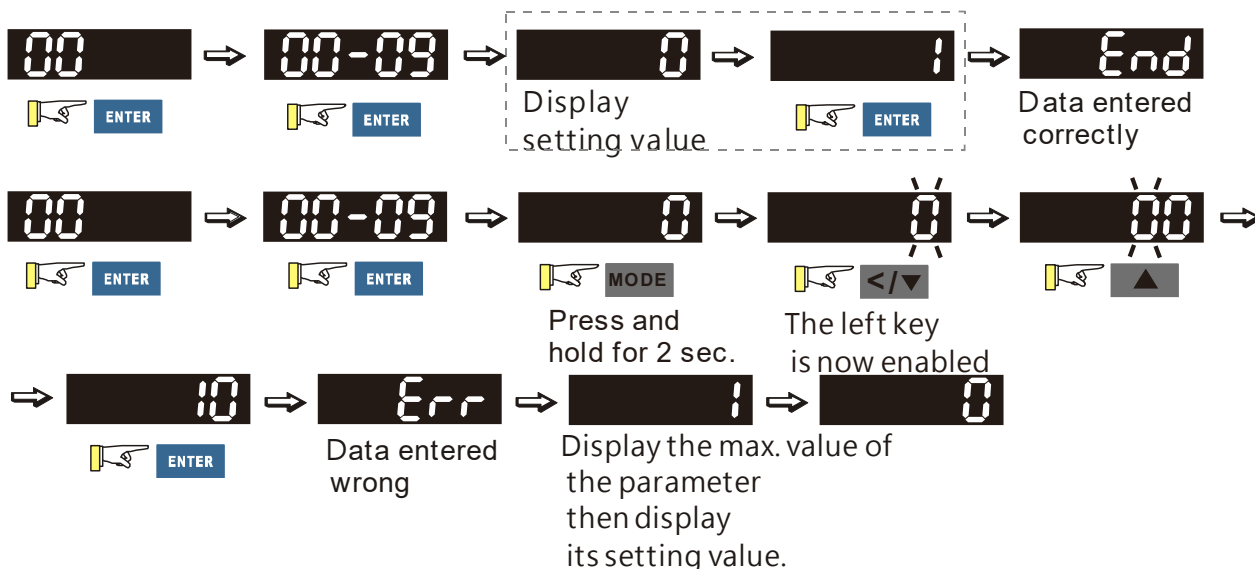

Note: In the parameter setting mode, press  to return to the mode selecting.

NOTE:

1. To disable LEFT key: press UP/ DOWN to adjust the number. When finishing the adjustment, press ENTER.
2. To enable the LEFT key: Press and hold MODE for two second until last digit of the parameter starts to blink. Now press UP, the value of the number increases. When the number reaches 9, press UP again, the number goes back to 0.
3. By pressing DOWN, the blinking cursor moves one digit to the left. Then press UP to increase the value of the number. Once reaching the desired number, press DOWN again to move the cursor one digit to the left.
4. When finishing setting the parameters, the LEFT function is still enabled. Press MODE for two seconds to disable LEFT function.

Modifying Data



Operating Direction

While the motor drive is controlled from a digital keypad.



Multi-Function Display Page

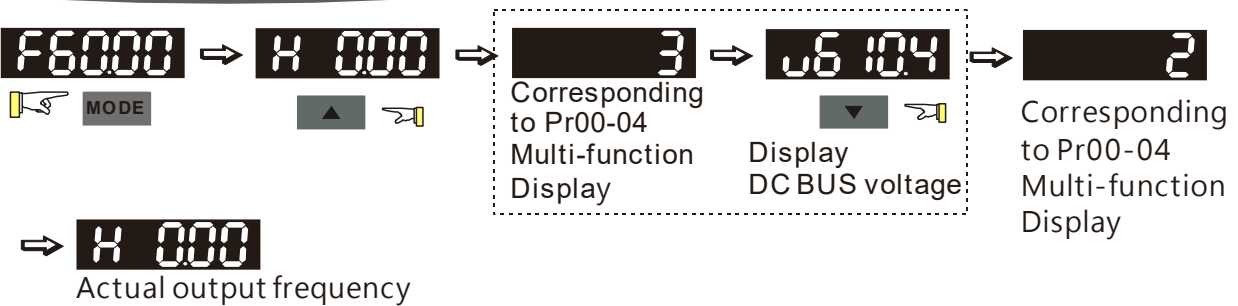

Display Fault/ Warning

Display Fault Codes

- (1) E 75 ↔ tH lo Press RESET to clear fault code
- (2) F 72 ↔ bro Repower on to clear fault code

Display Warning Codes



B. Frequency Command Page

Normal Mode 1 (Pr.01-02: Maximum Frequency has two digits. Example: Pr.01-02 = 60.00Hz)

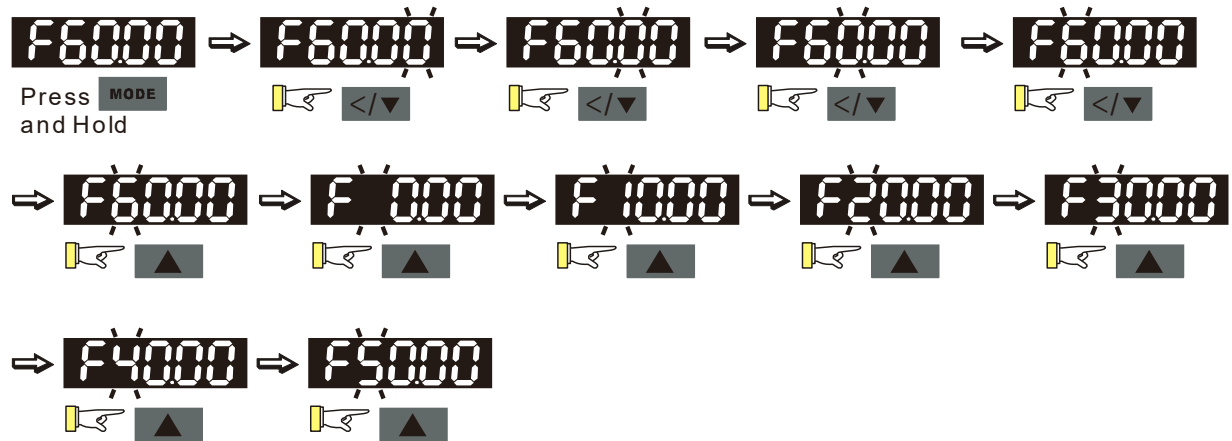

Normal Mode 2 (Pr.01-02: Maximum Frequency has three digits. Example: Pr.01-02 = 599.0Hz)

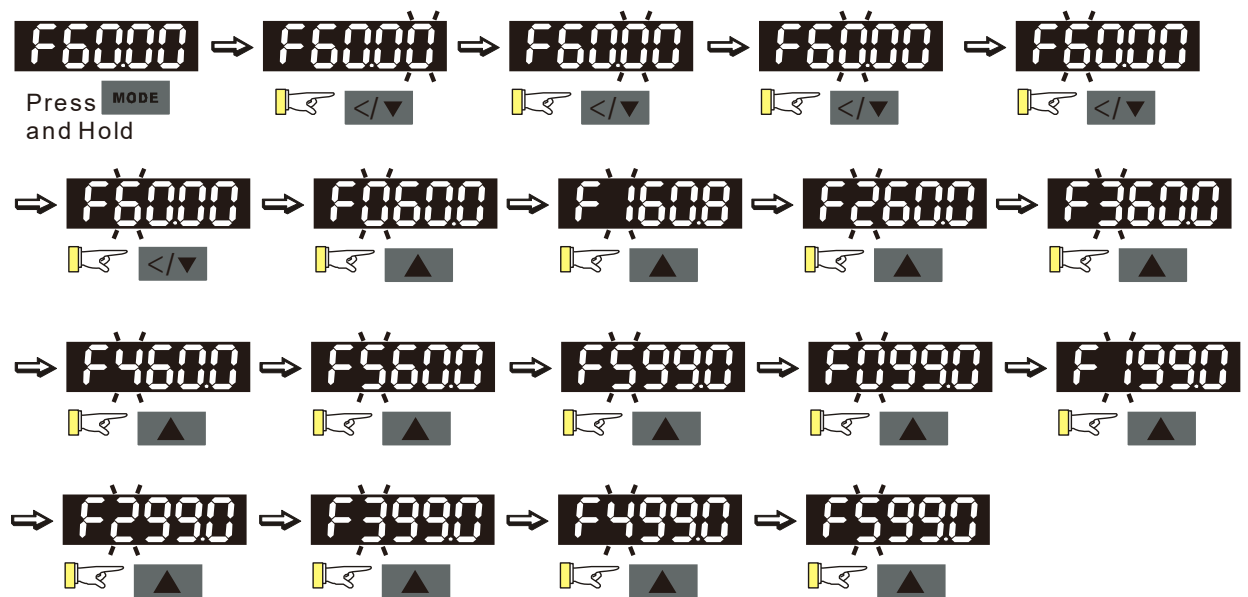

Reference Table for the 7-segment LED Display of the Digital Keypad

Numeric	0	1	2	3	4	5	6	7	8	9
Seven-segment Display										
English Letter	A	a	B	b	C	c	D	d	E	e
Seven-segment Display		-	-				-			-
English Letter	F	f	G	g	H	h	I	i	J	j
Seven-segment Display		-		-						
English Letter	K	k	L	l	M	m	N	n	O	o
Seven-segment Display		-		-	-	-	-		-	
English Letter	P	p	Q	q	R	r	S	s	T	t
Seven-segment Display		-	-		-			-	-	
English Letter	U	u	V	v	W	w	X	x	Y	y
Seven-segment Display			-		-	-	-	-		-
English Letter	Z	z								
Seven-segment Display		-								

3-2 Adjustment Flow Chart

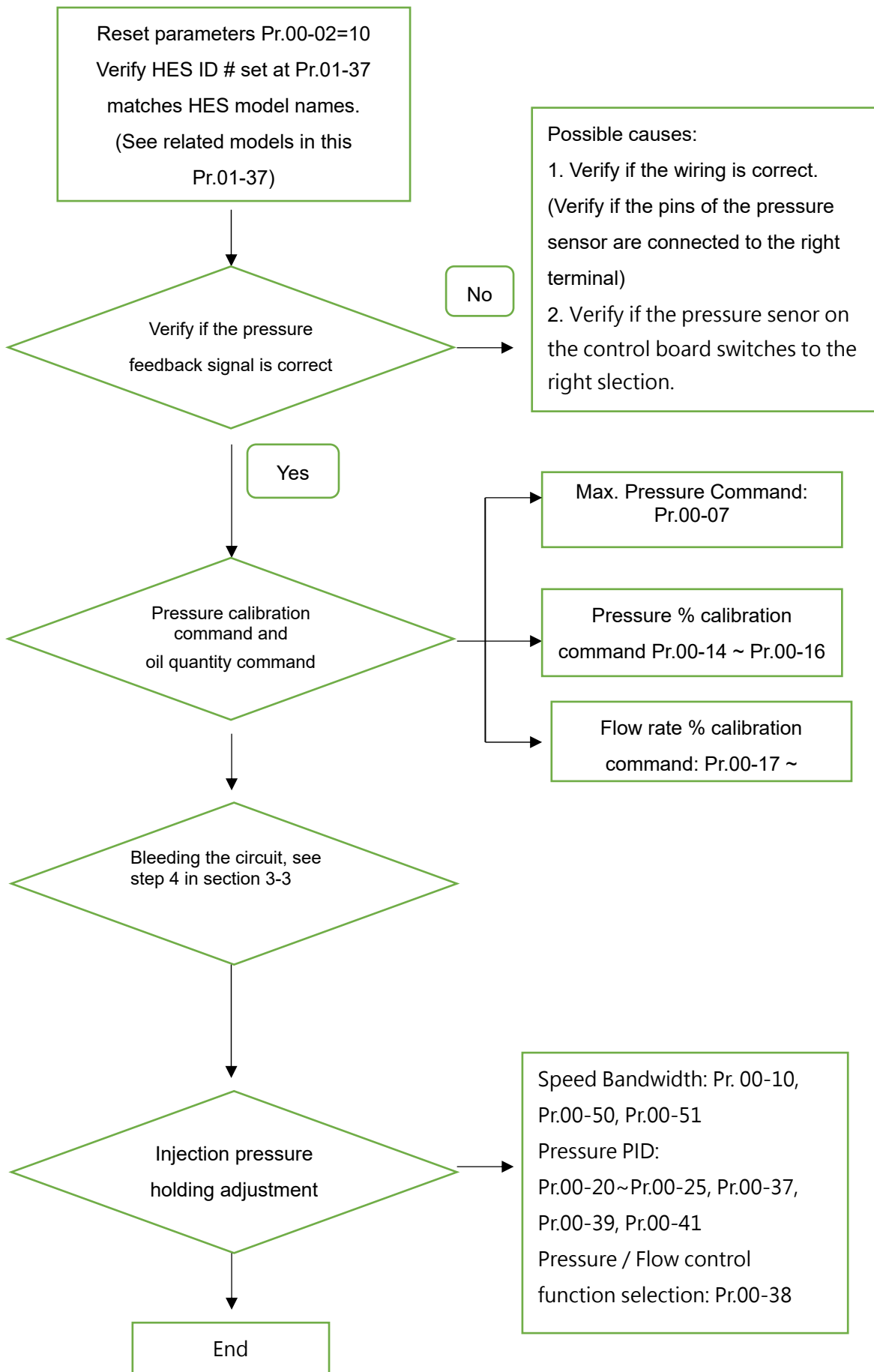

3-3 Machine Adjustment Procedure

Operate the following steps with the digital operator (KPVJ-LE02/ KPC-CC01)

Prior to starting running, please verify again if the wiring is correct, especially that the output terminals U/T1, V/T2, and W/T3 of the Hybrid Servo Controller must correspond to the U, V, and W terminals of the hybrid servo controller, respectively.

■

Step 1. Check Pressure Feedback Signal

- First, set input voltage Pr. 00-04 = 11, VJ-A.B: PO input voltage, VJ-C: PS input voltage

Step 2. Verify Pressure and Flow Commands

- Pr. 00-04 = 12 sets the PI input voltage

Selection of Display Mode

Pr. 00-04	12: Display the signal value of the PI analog input terminal, with 0~10V corresponding to 0~100%.
-----------	---------------------------------------------------------------------------------------------------

- Pr. 00-07 = corresponding pressure value with 10V on the pressure controller command
Maximum pressure command

Pr. 00-07	0~250Bar
-----------	----------

- With the maximum pressure set by the controller, observe the associated value displayed on the operation panel and set it to 00-14.
- With the controller setting at half the maximum pressure, observe the associated value displayed on the operation panel and set it to 00-15.
- With the controller setting at the lowest pressure, observe the associated value displayed on the operation panel and set it to 00-16.

Example: 10V on the pressure sensor corresponds to 250bar. If the maximum pressure on the controller is 140bar and corresponds to 10V, the Pr. 00-07=140. Set 140bar through the controller and the voltage reading displayed on the operation panel is approximately 56.0(140/250*100%). Enter this value to Pr. 00-14. Next, set 70bar through the controller and the voltage reading displayed on the operation panel is approximately 28.0 (70/250*100%). Enter this value to Pr. 00-15. Lastly, set 0bar through the controller and the voltage reading displayed on the operation panel is approximately 0.0(0/250*100%). Enter this value to Pr. 00-16.

Example: 10V on the pressure sensor corresponds to 250bar. However, the maximum pressure on the controller is 140bar and corresponds to 7V. As a result, Pr. 00-07=140/7*10=200. The following steps are the same as described in the previous example. Set 200bar through the controller first, followed by setting 100bar, and 0bar in the last step. Enter the corresponding values to the associated parameters.

- Pr. 00-06 = Display the speed (rpm) defined by the user (Default setting is the specification flow rate of HES.)

- Pr. 00-04 = 25 refers to the QI input voltage

Selection of Display Mode

Pr. 00-04	25: Displays the signal value of the QI analog input terminal, with 0~10V corresponding to 0~100%.
-----------	----------------------------------------------------------------------------------------------------

- Set 100% flow rate through the controller, observe the reading displayed on the operation panel and enter it to 00-17
- Set 50% flow rate through the controller, observe the reading displayed on the operation panel and enter it to 00-18
- Set 0% flow rate through the controller, observe the reading displayed on the operation panel and enter it to 00-19

Step 3. Send Run Command via Controller

- In case of power outage, connect SON-COM and turn on the power supply.

Step 4. Bleed the circuit and make sure if there is any plastic material in the barrel.

The machine can start operation only when there are no plastic materials inside the barrel.

- For low-pressure and low-speed conditions (within 30% of the rated values), use the “manual operation” through the controller for the operation of each cylinder. During the operation, check the pipe connection for leaks or strange noise in the pump.
- When the air is bleeding completely, if there is any pressure fluctuation during operation, please adjust the pressure control Parameter PI in accordance with the method described in the “Description of Parameters”.

■ **Activate the Oil Pump, Step by Step**

Step 1. Verify if there’s enough hydraulic oil in the oil tank before you turn on the power.

Step 2. After you turn on the power of the hybrid servo drive, use jogging to enable the oil pump. The jogging here means pressing ON button and release right away. Then you will hear the sound of oil pipe sucks in air. Repeat this step few more times until you no longer hear the sound of sucking in air.

Step 3. After you clear the air in the oil tank. Run the motor without any load at a rotation speed of 1200 RPM for 15minutes.

Step 4. After you finish Step 3 and before you start to test machinery, increase progressively the pressure by following the 5 stages below

For example: the maximum pressure is 1790bar and the maximum speed is 1200rpm. Apply jogging method while increase the pressure from stage 1 to stage 5.

Stage 1: 30bar
 Stag 2: 70 bar
 Stage 3: 100bar
 Stage 4:140bar
 Stage 5:170bar

You need to finish the 5 stages above then you can start to test the machinery

Step 5. Adjustment for injection/pressure holding

- Heat up the barrel to the required temperature and set the controller in manual control mode.
- Set the Ki value of the three-stage PI to 0 (Pr. 00-21, 00-23, and 00-25) and the three-stage Kp value to be small (≤ 50.0)
- Execute the injection, with “Preset Target” set at low pressure ($< 50\text{Bar}$) and low flow rate ($< 30\%$)
- Press “Injection” on the controller and the injection will be started or the system will directly enter the pressure holding operation (depending on the location of the oil cylinder)
- In the hold up state, Increase the speed bandwidth to the maximum value of 40Hz (Pr. 00-10) while causing no vibration to the hybrid servo motor.
- In the pressure holding state, when the pressure gauge needle or the monitored waveform shows no signs of vibration, the pressure feedback is stabilizing. Now the three sets of Kp values can be increased.
- When the pressure feedback becomes unstable, lower the three sets of Kp values by 20% (Example: lower the preset values of the three sets of Kp values from 100% to 80%), followed by adjusting the three sets of Ki values to eliminate the steady-state error and speed up the system response.
- Upon completion of the above steps, increase the pressure command of “Preset Target”.
- Observe if the pressure feedback becomes stable. Proceed with troubleshooting in case of any anomaly, as described below:

Troubleshooting for Pressure Instability

Unstable pressure over the entire section

1. Set Pr. 00-09 = 0 for speed control
2. With the oil line in the closed state, send the low speed rotation command to make the pressure feedback 40~50% of the pressure command value (Pr. 00-07)
3. Check if the pressure waveform shows any jitters through the monitoring software.
 - Jitter in Pressure Waveform

The possible cause is interference from ground. If the motor or the three-phase power supply is grounded, disconnect the ground wire. If the motor or the three-phase power supply is not grounded, add the ground wire for interference protection.

The other possibility is the ground issue of the shielding mesh (as illustrated by the bold red lines in the figure below). If the shielding mesh is grounded, disconnect the ground wire. If the shielding mesh is not grounded, add the ground wire for interference protection.

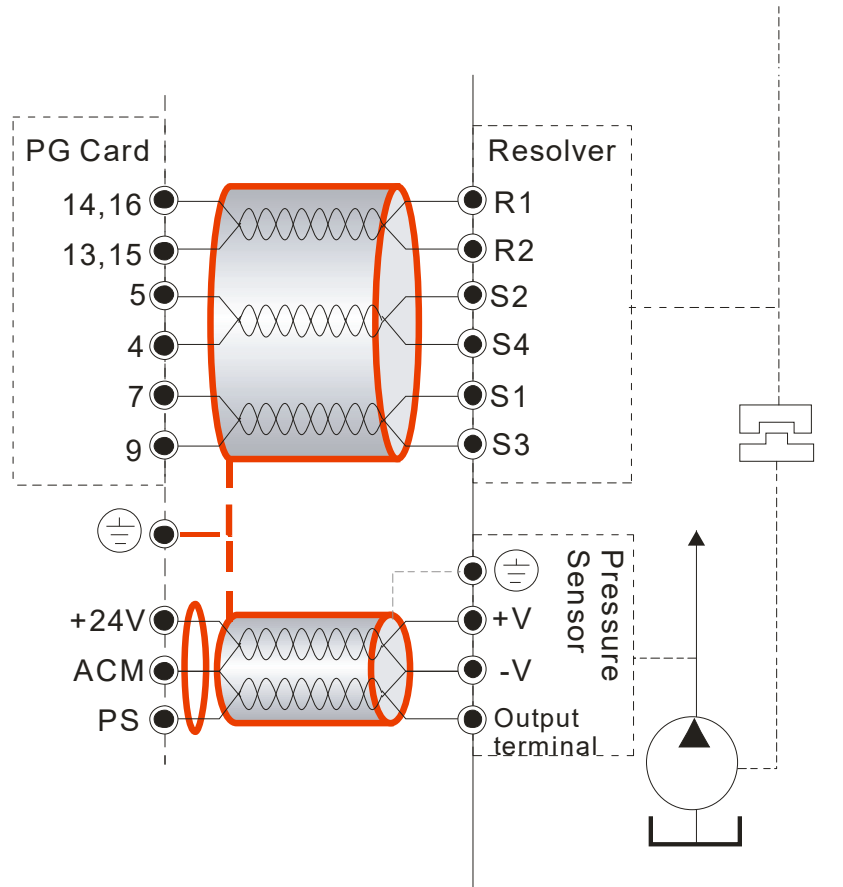

4. Please contact the original manufacturer if the anomaly still cannot be resolved after resorting to the methods described above.

Step 8. Adjustment of System Transient Response

- Reduce the pressure ramp up time by increasing Kp1 (Pr.00-20) and reducing Ki1 (Pr.00-21) times
- When the pressure is over-adjusted, increase Kp3 (Pr.00-24) and reduce Ki3 (Pr.00-25) times

3-4 Confluence Machine Tuning Procedure

Follow the associated descriptions in Chapter 2 to lay out the wiring.

Follow steps 1 and 2 described above to set up master/ slave. Then proceed with the steps below.

Master setting:

- Set the Parameter 03-13 = 1

Confluence Master/Slave Selection

Setting value of Pr. 03-13	0: No function
	1: Master 1
	2: Slave/Master 2
	3: Slave/Master 3

- Set the Parameter 03-14

Slave's proportion of the Master's flow

Setting value of Pr. 03-14	0.0~6553.5%
----------------------------	-------------

- Pr.03-17 can be configured to determine the activation level of the Slave

Slave's activation level

Setting value of Pr. 03-17	0~100%
----------------------------	--------

Slave setting:

Power off, disconnect SON-COM, then power on.

Set Pr.00-09 =0 <Speed Control>

-
-

- Set the Slave Pr.03-13 = 2 <Slave/Master 2>, verify if a one-way valve is installed at oil outlet.

Confluence Master/Slave Selection

Setting value of Pr. 03-13	0: No function
	1: Master 1
	2: Slave/Master 2
	3: Slave/Master 3

- Pr.03-21 can be set at the Slave to decide if the Slave is performing the reversed operation for depressurization.

Note: If it is required to reverse the operation for depressurization at the Slave, it is necessary to make sure that the oil outlet is not installed with a one-way valve

If a one-way valve is installed, set Pr.03-21 =0. If one-way valve is not installed, set Pr.03-21 =1 and Pr.03-16 = 500%.

Setting value	0: Disable
of Pr.03-21	1: Enable

Limit for the Slave reverse depressurization torque

Setting value	0~500%
of Pr. 03-16	

- Power off the Slave, connect SON-COM, then power on.

In this case, the Master can be tuned according to the steps described above

NOTE:

The detection of a slave disconnection of a multi-pumpp confluence can be detected by Pr.04-03 <COM time-out detection>. Once you detect a slave disconnection, follow the setting at Pr.04-02 to decide if to continue running or to stop running.

3-5 Confluence/Diversion Mode Adjustment Procedure

Follow the associated descriptions in Chapter 2 to lay out the wiring.

- Set Pr.03-13=1

Confluence Master / Slave selection

Setting of Pr.03-13	0: No function
	1: Master 1
	2: Slave/Master 2
	3: Slave/Master 3

- Set up Pr.03-14

The ratio between slave's flow and master's flow

Setting of Pr.03-14	0.0~6553.5%
---------------------	-------------

- Set up Pr.03-17

<Slave's activation level>

Setting of Pr.03-17	0~100%
---------------------	--------

Setting of Slave:

- Power off, disconnect SON-COM, then power on.
- Set Pr.00-09 =0 <speed control>
- Set the Slave Pr.03-13 = 2 <Slave/Master 2>, verify if a one-way valve is installed at oil outlet.

Confluence Master/Slave Selection

Setting of Pr.03-13	0: No function
	1: Master 1
	2: Slave/Master 2
	3: Slave/Master 3

- Pr.03-21 can be set at the Slave to decide if the Slave is performing the reversed operation for depressurization.

Note: If it is required to reverse the operation for depressurization at the Slave, it is necessary to make sure that the oil outlet is not installed with a one-way valve

If a one-way valve is installed, set Pr.03-21 =0. If one-way valve is not installed, set Pr.03-21 =1 and Pr.03-16 = 500%.

Setting of Pr.03-21	0: Diable
	1: Enable

Limit for the Slave reverse depressurization torque

Setting of Pr.03-16	0~500%
---------------------	--------

In this case, the Master can be tuned according to the steps described above

Setting of Slave:

- Pr.03-00 to Pr.03-02 = 45 < Confluence/Diversion signal input>

Multi-Function Input:

Setting of Pr03-00 to Pr03-02	0: No function
	45: Confluence / Diversion Signal Input

- Power off the slave, connect SON-COM, then power on. The upper controller runs the whole confluence / diversion process.

NOTE:

The detection of a slave disconnection of a multi-pumpp confluence can be detected by Pr.04-03 <COM time-out detection>. Once you detect a slave disconnection, follow the setting at Pr.04-02 to decide if to continue running or to stop running.

Chapter 4 Parameters

4-1 Summary of Parameter Settings

4-2 Description of Parameters

4-1 Summary of Parameter Settings

00 System Parameters

⚡ You can set this parameter during operation

Pr.	Function of the parameter	Settings	Default value	VF	FOCPG	FOCPM
00-00	Hybrid Servo Controller model code ID	214: 230V, 40HP 215: 230V, 50HP 410: 460V, 15HP 411: 460V, 20HP 412: 460V, 25HP 413: 460V, 30HP 414: 460V, 40HP 415: 460V, 50HP 416: 460V, 60HP 417: 460V, 75HP 418: 460V, 100HP	Read only	<input type="radio"/>	<input type="radio"/>	<input type="radio"/>
00-01	Display of rated current of the Hybrid Servo Controller	Display by models	Read only	<input type="radio"/>	<input type="radio"/>	<input type="radio"/>
00-02	Reset parameter settings	0: No function 1: Parameter locked 5: Rest the kWh when the motor drive stops 10: Reset parameter to default values 21: Reset counting time. NOTE: Two ways to reset CANopen as listed below: (1) Cycle the power. (2) Set Pr.04-17=0, then reset parameter to default value.	0	<input type="radio"/>	<input type="radio"/>	<input type="radio"/>
00-03	Software version	Read only	Read only	<input type="radio"/>	<input type="radio"/>	<input type="radio"/>

Pr.	Function of the parameter	Settings	Default value	VF	FOCPG	FOCPM
⚡ 00-04	Selection of multi-function display	0: Display the output current (A) (Unit: A) 1: Reserved 2: Display the actual output frequency (H) (Unit: Hz) 3: Display the DC-Bus voltage (U) (Unit: V) 4: Display the output voltage (E) 5: Display the output power angle (n) 6: Display the output power in kW (P) 7: Display the actual motor speed (r) (Unit: RPM) 8: Display the estimated output torque (%) 9: Display the PG feedback (G) 10: Reserved 11: Display the signal value of the analog input terminal PO % 12: Display the signal value of the analog input terminal PI % 13: Display the signal value of the analog input terminal AUI % 14: Display temperature of the heat sink in °C (t.) 15: Display temperature of IGBT in °C (T) 16: The status of digital input (ON/OFF) (i) 17: The status of digital output (ON/OFF) (o) 18: Reserved 19: The corresponding CPU pin status of the digital input (i.) 20: The corresponding CPU pin status of the digital output (o.) 21~24: Reserved 25: Display the signal value of the analog input terminal QI % (5.) (Unit: %) 26: Display the actual pressure value (Bar) (b.) (Unit: Bar) 27: Display the kWh value (K) (Unit: kWh) 28: Display the motor temperature (support KTY84-130) (T.) (Unit: °C) 29: Over load rate of motor drive (d) (Unit: %) 30: Over load rate of motor HES-A models (Unit: %) 31: Display current at braking (A.) (unit: A) 32: Temperature of the braking chopper (4.) (unit: °C) 33: Reserved 34: Torque constant Kt (K.) 35: Reserved 36: Reserved 37: Reserved 38: Reserved 39: Reserved 40: Reserved 41: # of times to switch on/off of the soft start relays (L) (%) 42: Amount of time to clean the cooling fans (F) %	0 (HES: 26)	<input type="radio"/>	<input type="radio"/>	<input type="radio"/>
⚡ 00-05	Version # of the secondary edition of the control board firmware.	Read only				
00-06	Display the speed defined by the user	0~39999 rpm	2500 (Default value of type M is 2000)	<input type="radio"/>	<input type="radio"/>	<input type="radio"/>
⚡ 00-07	Maximum value for the pressure command	0~400Bar	180 HES250G23C:140	<input type="radio"/>	<input type="radio"/>	<input type="radio"/>
⚡ 00-08	Maximum pressure feedback value	0~400 Bar	250	<input type="radio"/>	<input type="radio"/>	<input type="radio"/>

Pr.	Function of the parameter	Settings	Default value	VF	FOCPG	FOCPM
00-09	Pressure control mode	0: Speed control 1: Pressure control	1	<input type="radio"/>	<input type="radio"/>	<input type="radio"/>
00-10	Speed bandwidth	0~40Hz	20	<input type="radio"/>	<input type="radio"/>	<input type="radio"/>
✓ 00-11	Pressure feedback filtering time PO	0.000~1.000 second	0.000	<input type="radio"/>	<input type="radio"/>	<input type="radio"/>
✓ 00-12	Pressure command filtering time PI	0.000~1.000 second	0.000	<input type="radio"/>	<input type="radio"/>	<input type="radio"/>
✓ 00-13	Flow command filtering time QI	0.000~1.000 second	0.000	<input type="radio"/>	<input type="radio"/>	<input type="radio"/>
✓ 00-14	Percentage of the pressure command (Max)	0.0~100.0% (NOTE: Abbreviation of HES250G23C is G)	H: 72.0 G: 56.0	<input type="radio"/>	<input type="radio"/>	<input type="radio"/>
✓ 00-15	Percentage of the pressure command (Mid)	0.0~100.0%	H: 36.0 G: 28.0	<input type="radio"/>	<input type="radio"/>	<input type="radio"/>
✓ 00-16	Percentage of the pressure command (Min)	0.0~100.0%	0.0	<input type="radio"/>	<input type="radio"/>	<input type="radio"/>
✓ 00-17	Percentage of the flow command (Max)	0.0~100.0%	100.0	<input type="radio"/>	<input type="radio"/>	<input type="radio"/>
✓ 00-18	Percentage of the flow command (Mid)	0.0~100.0%	50.0	<input type="radio"/>	<input type="radio"/>	<input type="radio"/>
✓ 00-19	Percentage of the flow command (Min)	0.0~100.0%	0.0	<input type="radio"/>	<input type="radio"/>	<input type="radio"/>
✓ 00-20	P gain 1 (Proportional Gain 1)	0.0~1000.0	50.0	<input type="radio"/>	<input type="radio"/>	<input type="radio"/>
✓ 00-21	I integration time 1	0.00~500.00 seconds	2.00	<input type="radio"/>	<input type="radio"/>	<input type="radio"/>
✓ 00-22	P gain 2 (Proportional Gain 2)	0.0~1000.0	50.0	<input type="radio"/>	<input type="radio"/>	<input type="radio"/>
✓ 00-23	I integration time 2	0.00~500.00 seconds	2.00	<input type="radio"/>	<input type="radio"/>	<input type="radio"/>
✓ 00-24	P gain 3 (Proportional Gain 3)	0.0~1000.0	50.0	<input type="radio"/>	<input type="radio"/>	<input type="radio"/>
✓ 00-25	I integration time 3	0.00~500.00 seconds	2.00	<input type="radio"/>	<input type="radio"/>	<input type="radio"/>
✓ 00-26	Pressure stable region	0~100%	25	<input type="radio"/>	<input type="radio"/>	<input type="radio"/>
✓ 00-27	Base pressure	0.0~100.0%	0.1	<input type="radio"/>	<input type="radio"/>	<input type="radio"/>
✓ 00-28	Depressurization speed	0~100%	25	<input type="radio"/>	<input type="radio"/>	<input type="radio"/>
✓ 00-29	Ramp up rate of pressure command	0~1000ms	0	<input type="radio"/>	<input type="radio"/>	<input type="radio"/>
✓ 00-30	Ramp down rate of pressure command	0~1000ms	100	<input type="radio"/>	<input type="radio"/>	<input type="radio"/>
✓ 00-31	Ramp up rate of flow command	0~1000 ms	80	<input type="radio"/>	<input type="radio"/>	<input type="radio"/>
✓ 00-32	Ramp down rate of flow command	0~1000 ms	80	<input type="radio"/>	<input type="radio"/>	<input type="radio"/>
✓ 00-33	Valve opening delay time	0~200 ms	0 (motor ID is 40 during 300 ~399 ms)	<input type="radio"/>	<input type="radio"/>	<input type="radio"/>
00-34	Reserved					
✓ 00-35	Over-pressure detection level	0~400Bar	230	<input type="radio"/>	<input type="radio"/>	<input type="radio"/>
✓ 00-36	Detection of disconnection of pressure feedback	0 : No function 1: Enable (only for the pressure feedback output signal within 1~5V)	0	<input type="radio"/>	<input type="radio"/>	<input type="radio"/>
✓ 00-37	Differential gain	0.0~100.0 %	0.0	<input type="radio"/>	<input type="radio"/>	<input type="radio"/>

Pr.	Function of the parameter	Settings	Default value	VF	FOCPG	FOCPM
00-38	Pressure/flow control function selection	Bit 0: 0: Switch to the Pressure PI Gain and to speed bandwidth according to the pressure feedback level 1: Switch to the Pressure PI Gain and to speed bandwidth according to the multi-function input terminal Bit 1: 0: No pressure/flow rate control switch 1: Switch between the pressure and flow control. Bit 2: 0: Use the original pressure overshoot suppression 1: Use the new pressure overshoot suppression Bit3: 0: 0: Switch to the Pressure PI Gain and to speed bandwidth according to the pressure feedback level	0	<input type="radio"/>	<input type="radio"/>	<input type="radio"/>
↗ 00-39	I gain of pressure overshoot 1	0.00~500.00 seconds	0.2	<input type="radio"/>	<input type="radio"/>	<input type="radio"/>
↗ 00-40	differential gain 2	0.0~100%	0.0	<input type="radio"/>	<input type="radio"/>	<input type="radio"/>
↗ 00-41	differential gain 3	0.0~100%	0.0	<input type="radio"/>	<input type="radio"/>	<input type="radio"/>
↗ 00-42	Pressure overshoot level	0~100%	2	<input type="radio"/>	<input type="radio"/>	<input type="radio"/>
↗ 00-43	Percentage of maximum flow	0~100%	100	<input type="radio"/>	<input type="radio"/>	<input type="radio"/>
↗ 00-44	Pressure command	0~400.0 bar	0	<input type="radio"/>	<input type="radio"/>	<input type="radio"/>
↗ 00-45	Percentage of flow command	0.0~100.0%	0	<input type="radio"/>	<input type="radio"/>	<input type="radio"/>
↗ 00-46	Pressure reference S1 time	0~1000ms	0	<input type="radio"/>	<input type="radio"/>	<input type="radio"/>
↗ 00-47	Pressure reference S2 time	0~1000ms	0	<input type="radio"/>	<input type="radio"/>	<input type="radio"/>
↗ 00-48	Flow reference S1 time	0~1000ms	0	<input type="radio"/>	<input type="radio"/>	<input type="radio"/>
↗ 00-49	Flow reference S2 time	0~1000ms	0	<input type="radio"/>	<input type="radio"/>	<input type="radio"/>
↗ 00-50	Speed bandwidth 2	0~40Hz	20	<input type="radio"/>	<input type="radio"/>	<input type="radio"/>
↗ 00-51	Speed bandwidth 3	0~40Hz	20	<input type="radio"/>	<input type="radio"/>	<input type="radio"/>
↗ 00-52	Overpressure detection time	0.000~1.000sec	0.01	<input type="radio"/>	<input type="radio"/>	<input type="radio"/>
↗ 00-53	Oil shortage detection time	0.0~60.0sec	0.0	<input type="radio"/>	<input type="radio"/>	<input type="radio"/>
↗ 00-54	Pump running reversely detection time	0.0~60.0sec	0.0	<input type="radio"/>	<input type="radio"/>	<input type="radio"/>
00-55 ~ 00-58	Reserved					

✎	00-59	Minimum Flow	0.00~ 100.00%	5.00	○	○	○
✎	00-60	Oil Shortage Detecting Time at Startup	0 ~10 min	0	○	○	○
	00-61	Minimum Pressure 2	0.0 ~ 100.0%	0.1	○	○	○
	00-62	Minimum Flow 2	0.00 ~ 100.00%	5.00	○	○	○
	00-63	Pressure Releasing Valve Opening Time Interval	0.000 ~ 0.100 sec	0.100	○	○	○
	00-64 ~ 00-65	For specific customers only	For certain customers only				
	00-66	Multi-flow rate / speed command 1	0.00~599.00Hz	0	○	○	○
	00-67	Multi-flow rate / speed command 2	0.00~599.00Hz	0	○	○	○
	00-68	Multi-flow rate / speed command 3	0.00~599.00Hz	0	○	○	○
	00-69	Multi-flow rate / speed command 4	0.00~599.00Hz	0	○	○	○
	00--70	Multi-flow rate / speed command 5	0.00~599.00Hz	0	○	○	○
	00-71	Multi-flow rate / speed command 6	0.00~599.00Hz	0	○	○	○
	00-72	Multi-flow rate / speed command 7	0.00~599.00Hz	0	○	○	○
	00-73 ~ 00-90	For specific customers only	For certain customers only				
	00-91	Output quantity of oil pump	0~500 cc / rev 0: Turn off pressure loss detection	Default set at the factory according to the model name			
	00-92	Pressure loss detectiing time	0~60.0 sec 0: Turn off pressure dete	0.2			
	00-93	Pressure limit percentage	0~100%	10			

01 Motor Parameters

⚡ You can set this parameter during operation.

Pr.	Function of the parameter	Settings	Default value	VF	FOCPG	FOCPM
01-00	Control mode	0: VF 1: Reserved 2: Reserved 3: FOCPGIM (Induction Motor) 4: Reserved 5: FOCPGPM (Permanent Motor) 6: Reserved 7: Reserved	5	<input type="radio"/>	<input type="radio"/>	<input type="radio"/>
⚡ 01-01	Source of operation Command	0: Operation by using the digital keypad 1: Operation by using the external terminals. The Stop button on the keypad is disabled. 2: Communication using RS-485. The Stop button on the keypad is disabled 3: By CANopen	1	<input type="radio"/>	<input type="radio"/>	<input type="radio"/>
01-02	Motor's maximum operating Frequency	50.00~599Hz	Default set at the factory according to the model name	<input type="radio"/>	<input type="radio"/>	<input type="radio"/>
01-03	Motor's rated frequency	0.00~599Hz	Default set at the factory according to the model name	<input type="radio"/>	<input type="radio"/>	<input type="radio"/>
01-04	Motor's rated voltage	230V Series: 0.1V~255.0V 460V Series: 0.1V~510.0V	220.0 440.0	<input type="radio"/>	<input type="radio"/>	
⚡ 01-05	Acceleration time setting	0.00~600.00 seconds	0.00	<input type="radio"/>	<input type="radio"/>	<input type="radio"/>
⚡ 01-06	Deceleration time setting	0.00~600.00 seconds	0.00	<input type="radio"/>	<input type="radio"/>	<input type="radio"/>
01-07	Motor Parameter Auto Tuning	0: No function	0	<input type="radio"/>	<input type="radio"/>	
		1: Rolling test for induction motor(IM) (Rs, Rr, Lm, Lx, no-load current)		<input type="radio"/>	<input type="radio"/>	
		2: Static test for induction motor(IM)		<input type="radio"/>	<input type="radio"/>	
		3: Reserved		<input type="radio"/>	<input type="radio"/>	
		4: Measuring the angle between magnetic pole and PG origin by the dynamic test of SPM motor			<input type="radio"/>	<input type="radio"/>
		5: Parameter measurement by the dynamic test of SPM motor (Surface-mounted Permanent Magnet synchronous Motor)				<input type="radio"/>
		9: Angle measurement between magnetic pole and PG origin and parameter measurement by the dynamic test of SPM motor.			<input type="radio"/>	<input type="radio"/>
		13: Dynamic test for IPM motor (Interior permanent magnet synchronous motor)			<input type="radio"/>	<input type="radio"/>
		14: Correction of pressure feedback offset			<input type="radio"/>	<input type="radio"/>
01-08	Rated current of the induction motor (A)	40~120% of the drive's rated current	###		<input type="radio"/>	
⚡ 01-09	Rated power of the induction motor	0~655.35kW	###		<input type="radio"/>	

Pr.	Function of the parameter	Settings	Default value	V/F	FOCPG	FOCPM
01-10	Rated speed of the induction motor	0~65535rpm 1710 (60Hz 4-pole); 1410 (50Hz 4-pole)	1710		<input type="radio"/>	
01-11	Number of poles of the induction motor	2~20	4		<input type="radio"/>	
01-12	No-load current of the induction motor (A)	0~Default value of Parameter 01-08	###		<input type="radio"/>	
01-13	Stator resistance (Rs) of the induction Motor	0~65.535Ω	0		<input type="radio"/>	
01-14	Rotor resistance (Rr) of the induction Motor	0~65.535Ω	0		<input type="radio"/>	
01-15	Magnetizing inductance (Lm) of the induction Motor	0.0~6553.5mH	0		<input type="radio"/>	
01-16	Total leakage inductance (Lx) of the induction motor	0.0~6553.5mH	0		<input type="radio"/>	
01-17	Rated current of the synchronous motor	0~655.35 Amps	We've set up Pr.01-17 to Pr.01-24 of each hybrid servo drive before shipping it to you.			<input type="radio"/>
01-18	Rated power of the synchronous motor	0.00 – 655.35kW				<input type="radio"/>
01-19	Rated speed of the synchronous motor	0~65535rpm				<input type="radio"/>
01-20	Number of poles of the synchronous motor	2~20				<input type="radio"/>
01-21	Inertia of the synchronous motor's rotor	0.0~6553.5 *10 ⁻⁴ kg.m ²				<input type="radio"/>
01-22	Stator's phase resistance (Rs) of the synchronous motor	0.000~65.535Ω				<input type="radio"/>
01-23	Stator's phase inductance (Ld) of the synchronous motor	0.00.0~655.35mH				<input type="radio"/>
01-24	Stator's phase inductance (Lq) of the synchronous motor	0.00.0~655.35mH				<input type="radio"/>
01-25	Back EMF of the synchronous motor	0~65535 V/ krpm	0			<input type="radio"/>
01-26	Encode type	3: Resolver	3			<input type="radio"/>
01-27	PG Offset angle of synchronous motor	0.0~360.0°	0.0			<input type="radio"/>
01-28	Number of poles of the resolver	1~5	1			<input type="radio"/>
01-29	Encoder pulse	1~20000	1024		<input type="radio"/>	<input type="radio"/>

Pr.	Function of the parameter	Settings	Default value	VF	FOCPG	FOCPM
01-30	Encoder's input type setting	0: No function 1: Phase A leads in a forward run command and phase B leads in a reverse run command 2: Phase B leads in a forward run command and phase A leads in a reverse run command 3: Phase A is a pulse input and phase B is a direction input. (low input=reverse direction, high input=forward direction) 4: Phase A is a pulse input and phase B is a direction input. (low input=forward direction, high input=reverse direction) 5: Single-phase input	1		<input type="radio"/>	<input type="radio"/>
01-31	System control	0: No function 1: ASR automatic tuning 2: Estimation of inertia 2049: For HES-C only	HES-A: 1 HES-C: 2049, Default set at the factory according to the model name		<input type="radio"/>	<input type="radio"/>
⚡ 01-32	Unity value of the system inertia	1~65535 (256 = 1 per unit)	260		<input type="radio"/>	<input type="radio"/>
01-33	Carrier frequency	4~10kHz	5	<input type="radio"/>	<input type="radio"/>	<input type="radio"/>
⚡ 01-34	Reserved					
01-35	Motor ID	0 : Disabled See 4-2 Description of Parameter Settings for more information	Default set at the factory according to the model name	<input type="radio"/>	<input type="radio"/>	<input type="radio"/>
01-36	Change the rotation direction	0: When the driver runs forward, the motor rotates counterclockwise. When the driver runs reverse, the motor rotates clockwise. 1: When the driver runs forward, the motor rotates clockwise. When the driver runs reverse, the motor rotates counterclockwise.	0	<input type="radio"/>	<input type="radio"/>	<input type="radio"/>
01-37	HES ID #	0: Disabled See 4-2 Description of Parameter Settings for more information	Default set at the factory according to the model name	<input type="radio"/>	<input type="radio"/>	<input type="radio"/>
⚡ 01-38	Maximum Output Voltage	0~100V	10V	<input type="radio"/>	<input type="radio"/>	<input type="radio"/>

02 Parameters for Protection

✎ You can set this parameter during operation.

Pr.	Function of the parameter	Settings	Default value	VF	FOCPG	FOCPM
✎ 02-00	Software brake level	230V models: 350.0~450.0V _{DC} 460V models: 700.0~900.0V _{DC}	380.0 760.0	<input type="radio"/>	<input type="radio"/>	<input type="radio"/>
02-01	Present fault record	0: No error record	0	<input type="radio"/>	<input type="radio"/>	<input type="radio"/>
02-02	Second most recent fault record	1: Over-current during acceleration (ocA)	0	<input type="radio"/>	<input type="radio"/>	<input type="radio"/>
02-03	Third most recent fault record	2: Over-current during deceleration (ocd)	0	<input type="radio"/>	<input type="radio"/>	<input type="radio"/>
02-04	Fourth most recent fault record	3: Over-current during constant speed (ocn)	0	<input type="radio"/>	<input type="radio"/>	<input type="radio"/>
02-05	Fifth most recent fault record	4: Ground fault (GFF)	0	<input type="radio"/>	<input type="radio"/>	<input type="radio"/>
02-06	Sixth most recent fault record	5: IGBT short-circuit (occ)	0	<input type="radio"/>	<input type="radio"/>	<input type="radio"/>
		6: Over-current at stop (ocS)		<input type="radio"/>	<input type="radio"/>	<input type="radio"/>
		7: Over-voltage during acceleration (ovA)		<input type="radio"/>	<input type="radio"/>	<input type="radio"/>
		8: Over-voltage during deceleration (ovd)		<input type="radio"/>	<input type="radio"/>	<input type="radio"/>
		9: Over-voltage during constant speed (ovn)		<input type="radio"/>	<input type="radio"/>	<input type="radio"/>
		10: Over-voltage at stop (ovS)		<input type="radio"/>	<input type="radio"/>	<input type="radio"/>
		11: Low-voltage during acceleration (LvA)		<input type="radio"/>	<input type="radio"/>	<input type="radio"/>
		12: Low-voltage during deceleration (Lvd)		<input type="radio"/>	<input type="radio"/>	<input type="radio"/>
		13: Low-voltage during constant speed (Lvn)		<input type="radio"/>	<input type="radio"/>	<input type="radio"/>
		14: Low-voltage at stop (LvS)		<input type="radio"/>	<input type="radio"/>	<input type="radio"/>
		15: Phase loss protection (PHL)		<input type="radio"/>	<input type="radio"/>	<input type="radio"/>
		16: IGBT over-heat (oH1)		<input type="radio"/>	<input type="radio"/>	<input type="radio"/>
		17: Capacitor over-heat (oH2)		<input type="radio"/>	<input type="radio"/>	<input type="radio"/>
		18: TH1 open: IGBT over-heat protection circuit error (tH1o)		<input type="radio"/>	<input type="radio"/>	<input type="radio"/>
		19: TH2 open: Capacitor over-heat protection circuit error (tH2o)		<input type="radio"/>	<input type="radio"/>	<input type="radio"/>
		20: IGBT over heated and unusual fan function (oHF)		<input type="radio"/>	<input type="radio"/>	<input type="radio"/>
		21: Hybrid Servo Controller overload (oL)		<input type="radio"/>	<input type="radio"/>	<input type="radio"/>
		22: Motor over-load (EoL1)		<input type="radio"/>	<input type="radio"/>	<input type="radio"/>
		23: Reserved				
		24: Motor over-heat, detect by PTC (oH3)		<input type="radio"/>	<input type="radio"/>	<input type="radio"/>
		25: Reserved				
		26: Reserved		<input type="radio"/>	<input type="radio"/>	<input type="radio"/>
		27: Reserved		<input type="radio"/>	<input type="radio"/>	<input type="radio"/>
		28: Reserved		<input type="radio"/>	<input type="radio"/>	<input type="radio"/>
		29: Reserved		<input type="radio"/>	<input type="radio"/>	<input type="radio"/>
		30: Memory write error (cF1)		<input type="radio"/>	<input type="radio"/>	<input type="radio"/>
		31: Memory read error (cF2)		<input type="radio"/>	<input type="radio"/>	<input type="radio"/>
		32: Isum current detection error (cd0)		<input type="radio"/>	<input type="radio"/>	<input type="radio"/>
		33: U-phase current detection error (cd1)		<input type="radio"/>	<input type="radio"/>	<input type="radio"/>
		34: V-phase current detection error (cd2)		<input type="radio"/>	<input type="radio"/>	<input type="radio"/>
		35: W-phase current detection error (cd3)		<input type="radio"/>	<input type="radio"/>	<input type="radio"/>
		36: Clamp current detection error (Hd0)		<input type="radio"/>	<input type="radio"/>	<input type="radio"/>
		37: Over-current detection error (Hd1)		<input type="radio"/>	<input type="radio"/>	<input type="radio"/>
		38: Over-voltage detection error (Hd2)		<input type="radio"/>	<input type="radio"/>	<input type="radio"/>
39: Ground current detection error (Hd3)	<input type="radio"/>	<input type="radio"/>	<input type="radio"/>			
40: Auto tuning error (AuE)		<input type="radio"/>	<input type="radio"/>			
41: Reserved	<input type="radio"/>	<input type="radio"/>	<input type="radio"/>			
42: PG feedback error (PGF1)		<input type="radio"/>	<input type="radio"/>			
43: PG feedback loss (PGF2)		<input type="radio"/>	<input type="radio"/>			
44: PG feedback stall (PGF3)		<input type="radio"/>	<input type="radio"/>			

Pr.	Function of the parameter	Settings	Default value	VF	FOCPG	FOCPM
		45: PG slip error (PGF4)			<input type="radio"/>	<input type="radio"/>
		46: Reserved		<input type="radio"/>	<input type="radio"/>	<input type="radio"/>
		47: Reserved		<input type="radio"/>	<input type="radio"/>	<input type="radio"/>
		48: Reserved				
		49: External fault input (EF)		<input type="radio"/>	<input type="radio"/>	<input type="radio"/>
		50: Emergency stop (EF1)		<input type="radio"/>	<input type="radio"/>	<input type="radio"/>
		51: Reserved				
		52: Password input error for 3 consecutive times (PcodE)		<input type="radio"/>	<input type="radio"/>	<input type="radio"/>
		53: CPU error (cccod)		<input type="radio"/>	<input type="radio"/>	<input type="radio"/>
		54: Communication error (wrong command)(cE1)		<input type="radio"/>	<input type="radio"/>	<input type="radio"/>
		55: Communication error (wrong data address) (cE2)		<input type="radio"/>	<input type="radio"/>	<input type="radio"/>
		56: Communication error (wrong data) (cE3)		<input type="radio"/>	<input type="radio"/>	<input type="radio"/>
		57: Communication error (wrong data written address) (cE4)		<input type="radio"/>	<input type="radio"/>	<input type="radio"/>
		58: RS-485 Communication time out (cE10)		<input type="radio"/>	<input type="radio"/>	<input type="radio"/>
		59:Reserved		<input type="radio"/>	<input type="radio"/>	<input type="radio"/>
		60: Braking transistor error (bF)		<input type="radio"/>	<input type="radio"/>	<input type="radio"/>
		61~63: Reserved		<input type="radio"/>	<input type="radio"/>	<input type="radio"/>
		Reserved		<input type="radio"/>	<input type="radio"/>	<input type="radio"/>
		65: PG card information error or magnetic pole angle tuning error (PGF5)				<input type="radio"/>
		66: Over pressure (ovP)		<input type="radio"/>	<input type="radio"/>	<input type="radio"/>
		67: Pressure feedback fault (PfbF)		<input type="radio"/>	<input type="radio"/>	<input type="radio"/>
		68: Oil pump runs reversely (Prev)				
		69: Oil shortage warning (noil)				
		70: Reserved				
		71: Over current at Braking chopper (ocbs)				
		72: Braking resistor is open-circuit (bro)				
		73: Resistance of braking resistor is too small (brF)				
		74: Braking chopper overheated (oH4)				
		75: Error occurred on Brake chopper's thermal protection line (tH4o)				
		76~81: Reserved				
		82: Output Phase Loss on Phase U (oPL1)				
		83: Output Phase Loss on Phase V (oPL2)				
		84: Output Phase Loss on Phase W (oPL3)				
		85, 86, 88~100: Reserved				
		87: Hybrid servo drive overloading while running at low frequency (oL3)				
		101: Software error 1 occurred on CANopen (CGdE)				
		102: Software error 2 occurred on CANopen (CHbE)				
		103: Reserved				
		104: Hardware error occurred on CANopen (CbFE)				
		105: Index setting error occurred on CANopen (CIdE)				
		106: Slave # setting error occurred on CANopen (CAde)				
		107: CANopen index is out of range (CFrE)				
⚡	02-07	Low voltage level	160.0~220.0V _{DC} 320.0.0~440.0V _{DC}	180.0 360.0	<input type="radio"/>	<input type="radio"/>
⚡	02-08	Motor temperature	0: Warn and keep operation	1	<input type="radio"/>	<input type="radio"/>

Pr.	Function of the parameter	Settings	Default value	V/F	FOCPG	FOCPM
	protection action selection	1: Warn and ramp to stop 2: Warn and coast to stop				
02-09	Motor Temperature Protection level	0.0~150.0% 0.0~150.0°C	HES-A:120°C, HES-C:140°C	<input type="radio"/>	<input type="radio"/>	<input type="radio"/>
02-10	Reserved			<input type="radio"/>	<input type="radio"/>	<input type="radio"/>
02-11	Motor temperature protection type	0: Not assigned 1: KTY84-130 2: PTC130 3: Switch (N.C. model)	1	<input type="radio"/>	<input type="radio"/>	<input type="radio"/>
02-12	Motor fan activation level	0.0~150.0°C	50.0	<input type="radio"/>	<input type="radio"/>	<input type="radio"/>
02-13	Electronic thermal relay selection 1	0: Inverter motor 1: Standard motor 2: Disable	2	<input type="radio"/>	<input type="radio"/>	<input type="radio"/>
02-14	Electronic thermal characteristic for motor	30.0~600.0 seconds	60.0	<input type="radio"/>	<input type="radio"/>	<input type="radio"/>
02-15	Output frequency at malfunction	0.00~655.35 Hz	Read only	<input type="radio"/>	<input type="radio"/>	<input type="radio"/>
02-16	Output voltage at malfunction	0.0~6553.5 V	Read only	<input type="radio"/>	<input type="radio"/>	<input type="radio"/>
02-17	DC voltage at malfunction	0.0~6553.5 V	Read only	<input type="radio"/>	<input type="radio"/>	<input type="radio"/>
02-18	Output current at malfunction	0~655.35 Amps	Read only	<input type="radio"/>	<input type="radio"/>	<input type="radio"/>
02-19	IGBT temperature at malfunction	0.0~6553.5 °C	Read only	<input type="radio"/>	<input type="radio"/>	<input type="radio"/>
02-20	Clear errors automatically(LvX)	0: Disable, 1: Enable	0	<input type="radio"/>	<input type="radio"/>	<input type="radio"/>
02-21	Input the parameter protection password	1 ~ 9998	0			
02-22	Set up a parameter protection password	1~9988, 10000 ~ 65535	0			
02-32~02-31	Reserved					
02-32	Frequency Command at malfunction	0.00 ~ 599.00 Hz	Read only	<input type="radio"/>	<input type="radio"/>	<input type="radio"/>
02-33	Capacitor's temperature at malfunction	-3276.7~3276.7 °C	Read only	<input type="radio"/>	<input type="radio"/>	<input type="radio"/>
02-34	Motor's rotating speed at malfunction	-3276.7~3276.7 rpm	Read only	<input type="radio"/>	<input type="radio"/>	<input type="radio"/>
02-35	Torque command at malfunction	-3276.7~3276.7 %	Read only	<input type="radio"/>	<input type="radio"/>	<input type="radio"/>
02-36	Input Terminals' Status at malfunction	0 ~ 65535	Read only	<input type="radio"/>	<input type="radio"/>	<input type="radio"/>
02-37	Output Terminals' Status at malfunction	0 ~ 65535	Read only	<input type="radio"/>	<input type="radio"/>	<input type="radio"/>
02-38	Hybrid servo drive's status at malfunction	0 ~ 65535	Read only	<input type="radio"/>	<input type="radio"/>	<input type="radio"/>
02-39	Detecting Braking Resistor at startup	0: Disable, 1: Enable	1	<input type="radio"/>	<input type="radio"/>	<input type="radio"/>
02-40	Braking resistance	0.0 ~ 6553.5Ω	0.0	<input type="radio"/>	<input type="radio"/>	<input type="radio"/>
02-41	Limit of current	0 ~ 250%	200			
02-42	Maintenance period of the soft-start relay	0 ~ 65535 (X10) 0: Turn off the reminder of the remaining lifespan of the soft-start relay.	0			
02-43	Maintenance period of the cooling fan.	0 ~ 65535 hour 0: Turn off the reminder of the remaining maintenance hour of the cooling fan.	0			

03 Digital/Analog Input/Output Parameters

⚡ You can set this parameter during operation.

Pr.	Function of the parameter	Settings	Default value	VF	FOCPG	FOCPM
03-00	Multi-function input command 3 (MI3)	0: No function 44: Injection signal input	0	<input type="radio"/>	<input type="radio"/>	<input type="radio"/>
03-01	Multi-function input command 4 (MI4)	45: Confluence/Diversion signal input 46: Reserved	0	<input type="radio"/>	<input type="radio"/>	<input type="radio"/>
03-02	Multi-function input command 5 (MI5)	47: Multi-level pressure PI command 1 48: Multi-level pressure PI command 2 51: flow command	0	<input type="radio"/>	<input type="radio"/>	<input type="radio"/>
⚡ 03-03	Digital input response time	0.001~ 30.000 sec	0.005	<input type="radio"/>	<input type="radio"/>	<input type="radio"/>
⚡ 03-04	Digital input operation direction	0~65535	0	<input type="radio"/>	<input type="radio"/>	
⚡ 03-05	Multi-function output 1 (Relay 1)	0: No function 1: Operation indication	11	<input type="radio"/>	<input type="radio"/>	<input type="radio"/>
⚡ 03-06	Multi-function Output 2 (MO1)	9: Hybrid Servo Controller is ready 11: Error indication	0	<input type="radio"/>	<input type="radio"/>	<input type="radio"/>
⚡ 03-07	Multi-function Output 3 (MO2)	14: MO1 software brake output 44: Displacement switch signal 45: Motor fan control signal 46: Pressure release valve control signal	0	<input type="radio"/>	<input type="radio"/>	<input type="radio"/>
⚡ 03-08	Multi-function output direction	0~65535	0		<input type="radio"/>	
⚡ 03-09	Low-pass filter time of keypad display	0.001~65.535 seconds	0.100	<input type="radio"/>	<input type="radio"/>	<input type="radio"/>
03-10	Maximum output voltage for pressure feedback	5.0~10.0 V	10.0	<input type="radio"/>	<input type="radio"/>	<input type="radio"/>
03-11	Minimum output voltage for pressure feedback	0.0~2.0 V	0.0	<input type="radio"/>	<input type="radio"/>	<input type="radio"/>
⚡ 03-12	Type of Pressure Feedback Selection	0: Current 1: Voltage	1			
03-13	Confluence Master/Slave Selection	0: No function 1: Master 1 2: Slave/Master 2 3: Slave/Master 3	0	<input type="radio"/>	<input type="radio"/>	<input type="radio"/>
03-14	Slave's proportion of the Master's flow	0.0~65535.5 %	100.0	<input type="radio"/>	<input type="radio"/>	<input type="radio"/>
⚡ 03-15	Source of frequency command	0: Digital keypad 1: RS485 Communication 2~5: Reserved	0	<input type="radio"/>	<input type="radio"/>	<input type="radio"/>
⚡ 03-16	Limit for the Slave reverse depressurization torque	0~500%	20	<input type="radio"/>	<input type="radio"/>	<input type="radio"/>
⚡ 03-17	Slave's activation level	0.0~100.0%	50.0	<input type="radio"/>	<input type="radio"/>	<input type="radio"/>
03-18	Reserved					
03-19	Reserved					
⚡ 03-20	Start-up display selection	0: F (frequency command) 1: H (actual frequency) 2: Multi-function display (user-defined 00-04) 3: A (Output current)	0	<input type="radio"/>	<input type="radio"/>	<input type="radio"/>
⚡ 03-21	Slave reverse operation for depressurization	0: Disabled 1: Enabled	0	<input type="radio"/>	<input type="radio"/>	<input type="radio"/>
⚡ 03-22	Slave closing level	0 ~ 400	400	<input type="radio"/>	<input type="radio"/>	<input type="radio"/>

04 Communication Parameters

✎ You can set this parameter during operation

Pr.	Function of the parameter	Settings	Default value	VF	FOCPG	FOCPM
✎ 04-00	Communication address	1~254	1	<input type="radio"/>	<input type="radio"/>	<input type="radio"/>
✎ 04-01	COM transmission speed	4.8~115.2 Kbps	19.2	<input type="radio"/>	<input type="radio"/>	<input type="radio"/>
✎ 04-02	COM transmission fault treatment	0: Warn and continue operation 1: Warn and ramp to stop 2: Warn and coast to stop 3: No warning and continue operation	3	<input type="radio"/>	<input type="radio"/>	<input type="radio"/>
✎ 04-03	COM time-out detection	0.0~100.0 sec.	0.0	<input type="radio"/>	<input type="radio"/>	<input type="radio"/>
✎ 04-04	COM1 communication protocol	0: 7N1 (ASCII) 1: 7N2 (ASCII) 2: 7E1 (ASCII) 3: 7O1 (ASCII) 4: 7E2 (ASCII) 5: 7O2 (ASCII) 6: 8N1 (ASCII) 7: 8N2 (ASCII) 8: 8E1 (ASCII) 9: 8O1 (ASCII) 10: 8E2 (ASCII) 11: 8O2 (ASCII) 12: 8N1 (RTU) 13: 8N2 (RTU) 14: 8E1 (RTU) 15: 8O1 (RTU) 16: 8E2 (RTU) 17: 8O2 (RTU)	13	<input type="radio"/>	<input type="radio"/>	<input type="radio"/>
✎ 04-05	Delay time of communication response	0.0~200.0 ms	2.0	<input type="radio"/>	<input type="radio"/>	<input type="radio"/>
04-06	Main frequency of the communication	0.00~ 599.00 Hz	60.00	<input type="radio"/>	<input type="radio"/>	<input type="radio"/>
✎ 04-07	Block transfer 1	0.00~655.35	0.00	<input type="radio"/>	<input type="radio"/>	<input type="radio"/>
✎ 04-08	Block transfer 2	0.00~655.35	0.00	<input type="radio"/>	<input type="radio"/>	<input type="radio"/>
✎ 04-09	Block transfer 3	0.00~655.35	0.00	<input type="radio"/>	<input type="radio"/>	<input type="radio"/>
✎ 04-10	Block transfer 4	0.00~655.35	0.00	<input type="radio"/>	<input type="radio"/>	<input type="radio"/>
✎ 04-11	Block transfer 5	0.00~655.35	0.00	<input type="radio"/>	<input type="radio"/>	<input type="radio"/>
✎ 04-12	Block transfer 6	0.00~655.35	0.00	<input type="radio"/>	<input type="radio"/>	<input type="radio"/>
✎ 04-13	Block transfer 7	0.00~655.35	0.00	<input type="radio"/>	<input type="radio"/>	<input type="radio"/>
✎ 04-14	Block transfer 8	0.00~655.35	0.00	<input type="radio"/>	<input type="radio"/>	<input type="radio"/>
✎ 04-15	Block transfer 9	0.00~655.35	0.00	<input type="radio"/>	<input type="radio"/>	<input type="radio"/>
✎ 04-16	Block transfer 10	0.00~655.35	0.00	<input type="radio"/>	<input type="radio"/>	<input type="radio"/>
04-17	CANopen slave address	0: Disable 1~127	0	<input type="radio"/>	<input type="radio"/>	<input type="radio"/>
04-18	CANopen speed	0: 1 Mbps 1: 500 Kbps 2: 250 Kbps 3: 125 Kbps 4: 100 Kbps (Delta only) 5: 50 Kbps	0	<input type="radio"/>	<input type="radio"/>	<input type="radio"/>
04-19	CANopen warning record	bit 0: CANopen Guarding Time out bit 1: CANopen Heartbeat Time out Bit 2: CANopen SYNC Time out bit 3: CANopen SDO Time out bit 4: CANopen SDO buffer overflow bit 5: CAN bus Off bit 6: Error protocol of CANopen bit 8: The setting value of CANopen index failed	0	<input type="radio"/>	<input type="radio"/>	<input type="radio"/>

Pr.	Function of the parameter	Settings	Default value	VF	FOCPG	FOCPM
		bit 9: The setting value of CANopen address failed bit10: The checksum value of CANopen index failed				
04-20	CANopen decoding method	0: Delta defined decoding method 1: CANopen Standard DS402 protocol	1	<input type="radio"/>	<input type="radio"/>	<input type="radio"/>
04-21	CANopen communication status	0: Node reset state 1: Com reset state 2: Boot up state 3: Pre operation state 4: Operation state 5: Stop state	0	<input type="radio"/>	<input type="radio"/>	<input type="radio"/>
04-22	CANopen control status	0: Not ready for use state 1: Inhibit start state 2: Ready to switch on state 3: Switched on state 4: Enable operation state 7: Quick stop active state 13: Error reaction activation state 14: Error state	0	<input type="radio"/>	<input type="radio"/>	<input type="radio"/>
04-23	Reserved					
04-24	Communication decoding method	0: Decoding method 1 (20xx) 1: Decoding method 2 (60xx)	1	<input type="radio"/>	<input type="radio"/>	<input type="radio"/>

4-2 Description of Parameter Settings

00 System Parameters

⚡ You can set this parameter during operation

00-00

Hybrid Servo Controller model code ID

Control mode VF FOC PG FOC PM

Factory default: Read only

Settings Read only

00-01

Display of rated current of the Hybrid Servo Controller

Control mode VF FOC PG FOC PM

Factory default: Read only

Settings Read only



Parameter 00-00 is used to determine the capacity of the Hybrid servo motor which has been configured in this parameter in factory. In addition, the current value of Parameter (00-01) can be read out to check if it is the rated current of the corresponding model. Display value of the current value of Parameter 00-01 for the related Parameter 00-00.

230V Series								
Power (KW)	5.5	7.5	11	15	18.5	22	30	37
Horse Power (HP)	7.5	10	15	20	25	30	40	50
Model ID	12	14	16	18	20	22	214	215

460V Series											
Power (KW)	5.5	7.5	11	15	18.5	22	30	37	45	55	75
Horse Power (HP)	7.5	10	15	20	25	30	40	50	60	75	100
Model ID	13	15	410	411	412	413	414	415	416	417	418

00-02

Reset parameter settings

Control mode VF FOC PG FOC PM

Factory default: 0

Settings

- 0: No function
- 1: Parameter locked
- 5: Rest the kWh at drive stop
- 7: Reset CANopen inde
- 10: Reset parameter values
- 21: Reset cooling fan maintenance time.



If it is necessary to restore the parameters to factory default, just set this parameter to "10".

00-03

Software version

Control mode VF FOC PG FOC PM

Factory default: ###

Settings Read only

⚡ **00-04**

Selection of multi-function display

Control mode VF FOC PG FOC PM

Factory default: 0

Settings

- 0: Display the output current (A)
- 1: Reserved
- 2: Display the actual output frequency (H)
- 3: Display the DC bus voltage (U)
- 4: Display the output voltage (E)
- 5: Display the output power angle (n)
- 6: Display the output power in kW (P)
- 7: Display the actual motor speed(r 00: forward speed; - 00: negative speed)



8: Display the estimated output torque (%) (t 0.0: positive torque; - 0.0: negative torque) (%)	
9: Display the PG feedback (G)	
10: Reserved	
11: Display the signal value of the analog input terminal PO with 0~10V mapped to 0~100%	
12: Display the signal value of the analog input terminal PI with 0~10V mapped to 0~100%	
13: Display the signal value of the analog input terminal PI with -10~10V mapped to 0~100%	
14: Display temperature of the heat sink in °C (t.)	
15: Display temperature of the IGBT power module °C	
16: The status of digital input (ON/OFF)	
17: The status of digital output (ON/OFF)	
18: Reserved	
19: The corresponding CPU pin status of the digital input	
20: The corresponding CPU pin status of the digital output	
21~24: Reserved	
25: Display the signal value of the analog input terminal OI with 0~10V mapped to 0~100%	
26: Display the actual pressure value (Bar)	
27: Display the kWh value (unit: kWh)	
28: Display the motor temperature (currently only support KTY84-130) (unit: °C)	
29: Over load rate of hybrid servo controller (OL occurred when reaching 100%)	
30: Over load rate of motor of HES (EOL1 occurred when reaching 100%)	
31: Display current at braking (A.) (unit: A)	
32: Display temperature of the braking chopper (4.) (unit: °C)	
33: Reserved	
34: Torque constant KT (unit: K)	
35: Reserved	
36: Reserved	
37: Reserved	
38: Reserved	
39: Reserved	
41: # of times to switch on/off of the soft start relays (L) (%)	
42: Amount of time to clean the cooling fans (F) %	

This parameter defines the contents to be displayed in the U page of the digital keypad KPVJ-LE02 (as shown in the images above).



00-05 Version # of the secondary edition of the control board firmware

00-06 Display the speed defined by the user

Control mode **VF** **FOCPG** **FOCPM**

Factory default: 0
(Factory default of type M is 2000)

Settings 0~39999 rpm



-  Set the maximum speed of the motor corresponding to the 100% flow.
-  When the control mode is FOCPM(Pr01-00=5), Pr00-06 will follow the setting at Pr01-20 <Number of poles of the synchronous motor> to modify Pr01-02<Motor's maximum operating frequency>. frequency = rpm*Pole/120

00-07 Maximum value for the pressure command

Control mode **VF** **FOCPG** **FOCPM**

Factory default: 180
HES250G23C:140

Settings 0~400Bar

-  The 0~10V for the pressure command on the controller is mapped to 0~the value of this parameter.
-  When setting up Pr00-07 and Pr00-08, Pr00-14<Percentage for the pressure command value (Max) and Pr00-15<Percentage for the pressure command value (Mid) will also be modified. However when the pressure command is bigger than the pressure feedback, Pr00-07 cannot be set up.
-  Pr00-07 can be set up while the motor drive is running, but Pr00-07 has to be smaller than Pr00-08.

00-08 Maximum pressure feedback value

Control mode **VF** **FOCPG** **FOCPM**

Factory default: 250

Settings 0~400Bar



-  The 0~10V for the pressure sensor is mapped to 0~the value of this parameter.

00-09 Pressure control mode

Control mode **VF** **FOCPG** **FOCPM**

Factory default: 1

Settings 0: Speed control
1: Pressure control

-  This parameter determines the control mode of the Hybrid Servo Controller. It is recommended to use the speed control at the initial start up. After the motor, pump, pressure sensor, and the entire system are checked without any error, switch to the pressure control mode to enter the process control.
-  When under Pr00-09<Pressure control mode>, Pr01-05<Acceleration time setting> and Pr01-06<Deceleration time setting> have to be set as 0 to make the pressure control mode stable.

00-10 Speed bandwidth

Control mode **FOCPG** **FOCPM**

Factory default: 20

Settings 0~40Hz

-  Set the speed response. The larger value indicates the faster response.

⚡ 00-50 Speed Bandwidth 2

Control mode **FOCPG FOCPM** Factory setting: 20
 Settings 0 ~ 40Hz

⚡ 00-51 Speed bandwidth 3

Control mode **FOCPG FOCPM** Factory setting: 20
 Settings 0 ~ 40Hz

📖 Set the speed response. The larger value indicates the faster response.

⚡ 00-11 Pressure feedback filtering time PS

⚡ 00-12 Pressure Command Filter Time PI

⚡ 00-13 Pressure Command Filter Time QI

Control mode **VF FOCPG FOCPM** Factory default: 0.000
 Settings 0.000~1.000 seconds

📖 Noises may reside in the analog input signals of the control terminals PO, PI, and QI. The noise may affect the control stability. Use an input filter to eliminate such noise.

📖 If the time constant is too large, a stable control is obtained with poorer control response. If it is too small, a fast response is obtained with unstable control. If the optimal setting is not known, adjust it properly according to the instability or response delay.

⚡ 00-14 Percentage of the pressure command (Max)

Control mode **VF FOCPG FOCPM** Factory default: H:72.0 /
 G: 56.0
 Settings 0.0 ~ 100.0%

⚡ 00-15 Percentage of the pressure command (Mid)

Control mode **VF FOCPG FOCPM** Factory default: H:36.0 /
 G: 28.0
 Settings 0.0 ~ 100.0%

⚡ 00-16 Percentage of the pressure command (Min)

Control mode **VF FOCPG FOCPM** Factory default: 0.0
 Settings 0.0 ~ 100.0%

📖 When setting up Pr00-07<Max. value for the pressure command> and Pr00-08<Max. pressure feedback value>, Pr00-14 and Pr00-15 will also be modified. However when the pressure command is bigger than the pressure feedback, Pr00-07 cannot be set up.

📖 Pr00-07 can be set up while the motor drive is running, but Pr00-07 has to be smaller than Pr00-08.

📖 To set these parameters, it is necessary to set Parameter 00-09 as 1
 Parameter 00-04 = 12 for PI input voltage

Send the maximum pressure command through the controller and then check the multi-function display page to enter this value into 00-14

Send a half pressure command through the controller and then check the multi-function display page to enter this value into 00-15

Send the minimum pressure command through the controller and then check the multi-function display page to enter this value into 00-16

Example: If the pressure sensor indicates 250bar at 10V. If the controller’s maximum pressure of 140bar corresponds to 10V, then Parameter 00-07=140. Set the pressure as 140bar by using the controller, the voltage value shown on the display is about 56.0 (140/250 * 100%). Enter this value into the Parameter 00-14. Then set the pressure as 70bar on the controller, and now the value displayed on the keypad is about 28.0 (70/250 * 100%). Enter this value to the Parameter 00-15. Then set the pressure as 0 bar on controller, and the voltage value shown on the keypad is about 0.0 (0/250 * 100%). Enter this value in the Parameter 00-16.

↗	00-17	Percentage of the flow command (Max)	Control mode	VF	FOCPG	FOCPM	Factory default: 100.0
			Settings	0.0~100.0%			
↗	00-18	Percentage of the flow command (Mid)	Control mode	VF	FOCPG	FOCPM	Factory default: 50.0
			Settings	0.0~100.0%			
↗	00-19	Percentage of the flow command (Min)	Control mode	VF	FOCPG	FOCPM	Factory default: 0.0
			Settings	0.0~100.0%			

📖 To set these parameters, it is necessary to set Parameter 00-09 as 1

📖 Parameter 00-04 = 25 for QI input voltage

Send the 100% flow rate through the controller and then check the multi-function display page to enter this value into 00-17

Send the 50% flow rate through the controller and then check the multi-function display page to enter this value into 00-18

Send the 0% flow rate through the controller and then check the multi-function display page to enter this value into 00-19

↗	00-20	P gain 1	Control mode	VF	FOCPG	FOCPM	Factory default: 50.0
			Settings	0.0~1000.0			
↗	00-22	P gain 2					
↗	00-24	P gain 3					
↗	00-21	I integration time 1	Control mode	VF	FOCPG	FOCPM	Factory default: 2.00
			Settings	0.00~500.00 seconds			
↗	00-23	I integration time 2					
↗	00-25	I integration time 3					

↗	00-37	Differential gain	Control mode	VF	FOCPG	FOCPM	Factory setting: 0.0
			Settings	0.0~100.0 %			
↗	00-40	Differential gain 2					
↗	00-41	Differential gain 3					

📖 This parameter is functional only when Bit0 and Bit2 = 1 at Pr00-38.

00-26 Pressure stable region

Control mode **VF** **FOCPG** **FOCPM**
 Settings 0~100%

Factory default: 25

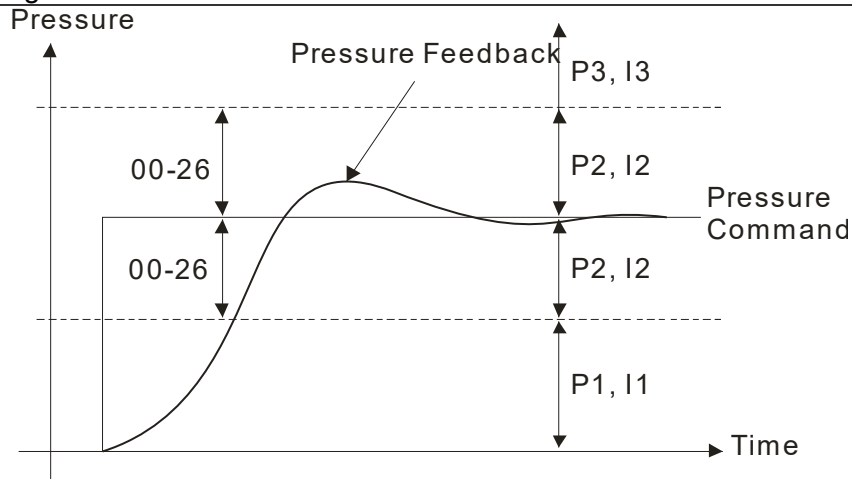

Adjust the Kp value to a proper level first, and then adjust the Ki value (time). If the pressure has overshoot, adjust the kd value.

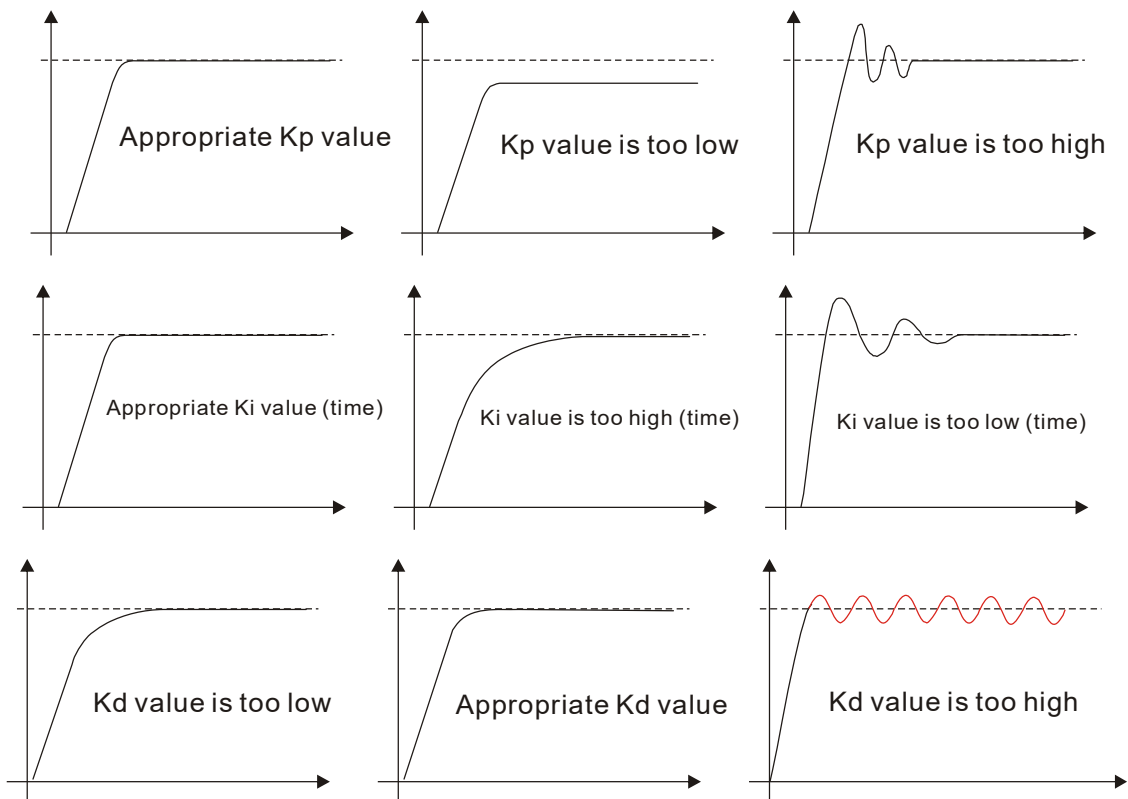

00-27 Minimum pressure

Control mode **VF** **FOCPG** **FOCPM**
 Settings 0.0~100.0%

Factory default: 2

Set the minimum pressure value 100% corresponding to Parameter 00-08

Typically, it is necessary to maintain a certain base pressure to ensure that the oil pipe is in fully filled condition so as to avoid the activation delay of the cylinder when a pressure/flow command is activated.

00-28 Depressurization speed

Control mode **VF** **FOCPG** **FOCPM**
 Settings 0~100%

Factory default: 25

Set the highest rotation speed at depressurization. The 100% value is mapped to Pr.01-02 (the maximum rotation speed of the motor)

↗ **00-29** Ramp up rate of pressure command
 Control mode **VF** **FOCPG** **FOCPM** Factory default: 0
 Settings 0~1000ms

↗ **00-30** Ramp down rate of pressure command
 Control mode **VF** **FOCPG** **FOCPM** Factory default: 100
 Settings 0~1000ms

- 📖 Ramp the pressure value for the pressure command so as to reduce the vibration of the machine.
- 📖 Set the time required for ramping the pressure from 0~the maximum pressure (Pr.00-08).

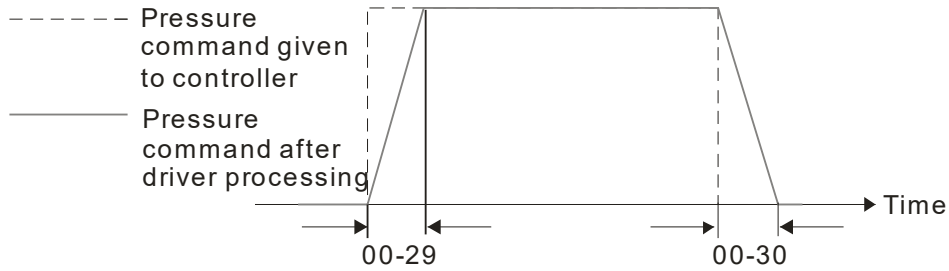

↗ **00-31** Ramp up rate of flow command
↗ **00-32** Ramp down rate of flow command
 Control mode **VF** **FOCPG** **FOCPM** Factory default: 80
 Settings 0~1000ms

- 📖 Ramp the flow value for the flow command so as to reduce the vibration of the machine.
- 📖 Set the time required for ramping the flow from 0~the maximum flow (Pr.01-02).

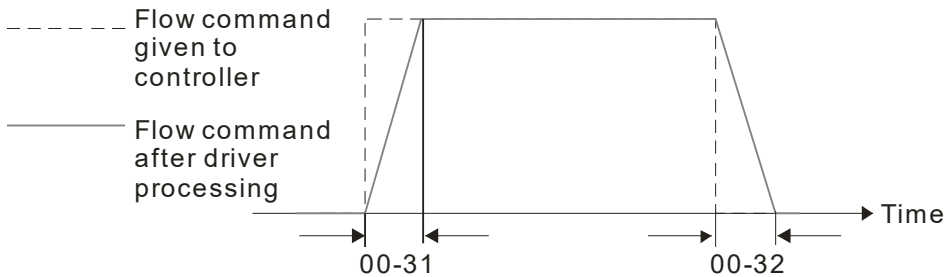

↗ **00-33** Valve opening delay time
 Control mode **VF** **FOCPG** **FOCPM** Factory default: 0
 Settings 0~200ms

- 📖 When both the pressure command and flow command activate the machine to start from idle, the flow starts to output. However, due to the slower response of the valve in the hydraulic circuit, the sudden surge of the pressure may occur. The pressure may recover to normal till the valve is fully opened. To avoid the aforementioned effect, set this parameter to increase time for the flow output delay.

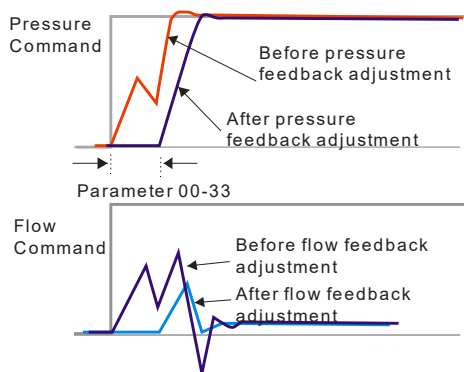

00-34 Reserved

00-35 Overpressure detection level

Control mode **VF** **FOCPG** **FOCPM**
 Settings 0~400 Bar

Factory default: 230

When the pressure feedback exceeds this parameter setting, an “ovP over pressure” error message may occur.

00-52 Overpressure Detection Time

Control mode **VF** **FOCPG** **FOCPM**
 Settings 0.0000~ 1.0000 sec

Factory default: 0.01

When Pr00-35=0, the overpressure detection is disable.

00-36 Detection of disconnection of pressure feedback

Control mode **VF** **FOCPG** **FOCPM**
 Settings 0: No function

Factory default: 0

1: Enable (only for the pressure feedback output signal within 1~5V and 4~20mA)

When this parameter is set as 1 and if the pressure feedback signal is below 1V or 4mA, an “Pfbf pressure feedback fault” message may occur.

00-38 Pressure/flow control function selection

Control mode **VF** **FOCPG** **FOCPM**

Factory default: 0

Settings

Bit 0:
 0: Switch the PI Gain according to the pressure feedback level
 1: Switch the PI Gain according to the multi-function input terminal

Bit 1:
 0: No pressure/flow control switch
 1: Switch between the pressure and flow control

Bit 2:
 0: Use the old pressure overshoot suppression
 1: Use the new pressure overshoot suppression

Bit3:
 0: Switch the PI Gain and single speed bandwidth according to the pressure feedback level.
 1: Switch the PI Gain and speed bandwidth according to the pressure command.

When the Bit 0 of this parameter is set as 1, the PI Gain for the pressure can be switched in conjunction with the multi-function input terminal

Set Bit2 = 0		
Multi-function input terminal = 47	Multi-function input terminal = 48	
OFF	OFF	PI1 (Pr.00-20 and Pr.00-21) and Pr.00-10: Speed Bandwidth
ON	OFF	PI2 (Pr.00-22 and Pr.00-23) and Pr.00-50: Speed Bandwidth 2
OFF	ON	PI3 (Pr.00-24 and Pr.00-25) and Pr.00-51: Speed Bandwidth
Set Bit2 = 1		
Multi-function input terminal = 47	Multi-function input terminal = 47	
OFF	OFF	PID1 (Pr.00-20, Pr.00-21 and Pr.00-37) and

		Pr.00-10: Speed Bandwidth
ON	OFF	PID2 (Pr.0-22, Pr.02-23 and Pr.00-40) and Pr.00-50 Speed Bandwidth 2
OFF	ON	PID3 (Pr.00-24, Pr.00-25 and Pr.00-41) and Pr.00-51: Speed Bandwidth 3

- 📖 When the Bit 1 of this parameter is set as 1, the pressure feedback is lower than the pressure stable region (please refer to the description of Pr.00-26) so the flow control will be performed. When it enters the pressure stable region, the pressure control will be applied.
- 📖 When Bit1= 0, the Pressure Response is slow and the pressure overshoot is weak. When Bit1 = 1, the Pressure Response is fast and the pressure overshoot is strong.
- 📖 Set Bit2 = 0, the setting at Pr.00-39 and Pr.00-42 are used to suppress pressure overshoot. But when Bit2 = 1, the setting at Pr.00-37 is used to suppress pressure overshoot.
- 📖 When Bit3 =1:

Pressure Command	P, I Gain and Speed Bandwidth	D (Set Bit2 =1)
Smaller than or equal to the maximum pressure command (Pr.00-07)*25%	PI1 (Pr.00-20 and Pr.00-21) and Pr.00-10: Speed Bandwidth	Pr.00-37
Equal to the maximum value for pressure command (Pr.00-07)	PI2 (Pr.00-22 and Pr.00-23) and Pr.00-50: Speed Bandwidth 2	
Pressure command between 25% and 100%.	The PI Gain and Speed Bandwidth can be obtained by calculating the linear interpolation.	

- ⚡ **00-39** Integration Time – Pressure Overshoot 1
Control mode VF FOC PG FOC PM Factory default : 0.2
Settings 0.00~500.00 seconds
- ⚡ **00-42** Level of the pressure overshoot
Control mode VF FOC PG FOC PM Factory default : 2
Settings 0~100%

- 📖 By using the factory setting 250 bar of the Pr.00-08 Maximum Pressure Feedback, when the pressure is over 5 bar (250*2%=5 bar), another integral time of Pr00-39 will do overshoot protection.
- 📖 When the bit2 of Pr.00-38=1 , Pr.00-42 is disabled.

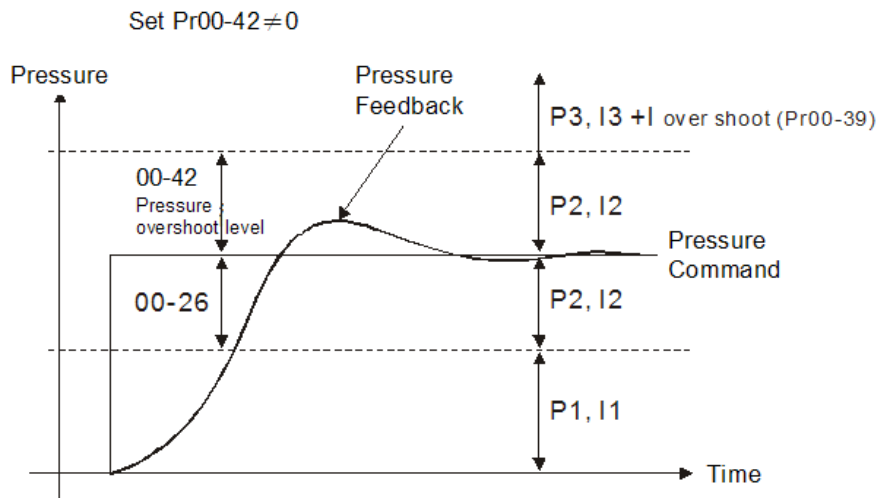
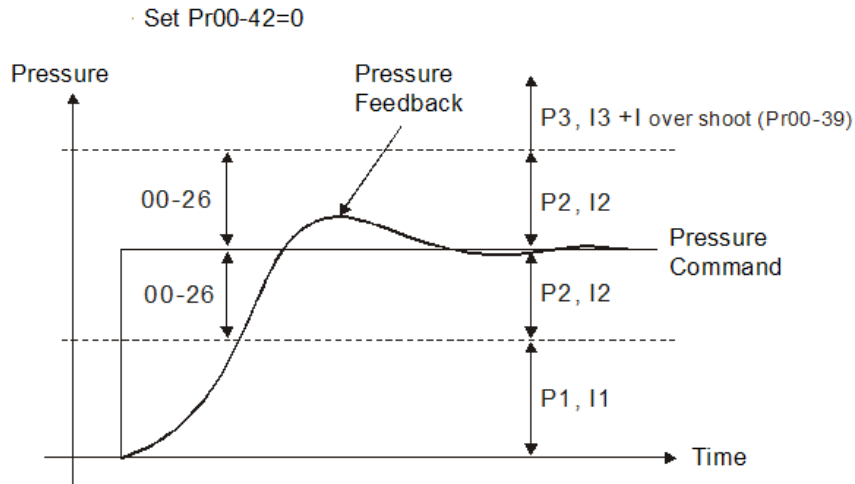

⚡ **00-43** Percentage of the maximum flow

Control mode VF FOC PG FOC PM

Factory default : 100

Settings 0~100%

📖 Set up this parameter to adjust the maximum rotation frequency (maximum flow rate). It is not necessary to stop the motor drive to set up this parameter. When this parameter is set to be 100%, it corresponds to the maximum rotation frequency of Pr01-02.

⚡ **00-44** Pressure Command

Control mode VF FOC PG FOC PM

Factory default : 0

Settings 0~400bar

⚡ **00-45** Percentage of Flow command

Control mode VF FOC PG FOC PM

Factory default: 0

Settings 0~100%

- 📖 When Pr.00-44 ≠ 0, Pressure Command will not be given by the analog signal but input by Pr.00-44.
- 📖 When Pr.00-45 ≠ 0, Flow Command will not be given by the analog signal but input by Pr.00-45.
- 📖 Pr.00-44 & Pr.00-45 can be applied in an environment without input of analog signal to do simple test.

↗ **00-46** Pressure Command Rising/ Descending S1 curve
 Control mode **VF FOC PG FOC PM** Factory default : 0
 Settings 0~1000ms

↗ **00-47** Pressure Command Rising/ Descending S2 Curve
 Control mode **VF FOC PG FOC PM** Factory default : 50
 Settings 0~1000ms

📖 To increase the smoothness at start or stop while increasing or decreasing the percentage of the pressure command. The longer the pressure reference time, the smoother it will be.

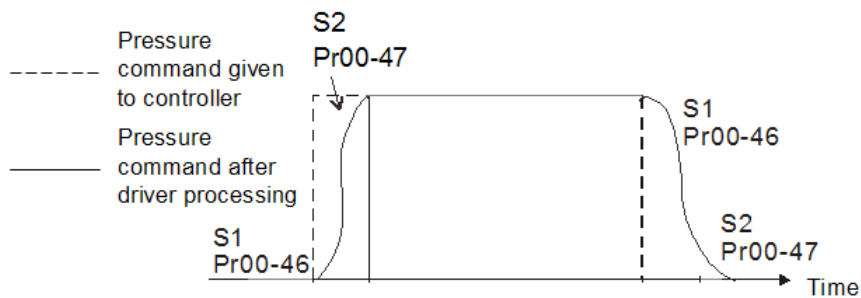

↗ **00-48** Pressure Command Rising/ Descending S1 Curve
 Control mode **VF FOC PG FOC PM** Factory default : 50
 Settings 0~1000ms

↗ **00-49** Flow Command Rising/.Descending S2 Curve
 Control mode **VF FOC PG FOC PM** Factory default : 50
 Settings 0~1000ms

📖 To increase the smoothness at start or stop while increasing or decreasing the percentage of the flow command. The longer the flow reference time, the smoother it will be.

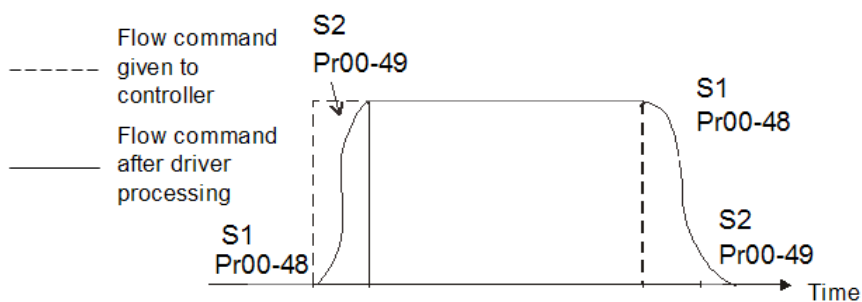

⚡	00-50	Speed bandwidth 2
Control mode	FOCPG FOCPM	Factory default : 20
Settings	0 ~ 40Hz	

⚡	00-51	Speed bandwidth 3
Control mode	FOCPG FOCPM	Factory default : 20
Settings	0 ~ 40Hz	

📖 To set up the response speed, the larger the value, the faster the response.

⚡	00-53	Oil shortage detection time
Control mode	VF FOCPG FOCPM	Factory default : 0.0
Settings	0.0 ~ 60.0 sec	

📖 When the actual pressure is lower than the minimum pressure (Pr.00-27) and exceeds the time set at Pr00-53, an oil shortage warning will pop up on the keypad.

📖 This parameter is functional only when Pr00-09 (Pressure control mode) = 1.

📖 When this parameter is set to 0, it is disabled.

⚡	00-54	Oil pump running reversely detection time
Control mode	VF FOCPG FOCPM	Factory default : 0.0
Settings	0.0 ~ 60.0 sec	

📖 When the oil pump runs reversely and exceeds the time set at Pr00-54, a reverse running pops up.

📖 When this parameter is set to 0, it is disabled.

00-55	Reserved
~	
00-58	

⚡	00-59	Minimum Flow
Control mode	VF FOCPG FOCPM	Factory setting: 5.00
Settings	0.00 ~ 100.00%	

📖 To set the minimum pressure, the 100% of Pr.00-27 matches the setting at Pr.00-08 and the 100% of Pr.00-55 matches the setting at Pr.01-02.

📖 It is necessary to maintain a minimum flow to make sure that the oil passage is filled with oil at all times. So that there will not be a delay on oil tank activation when sending a pressure/ flow command.

⚡	00-61	Minimum Pressure 2
Control mode	VF FOCPG FOCPM	Factory setting: 0.1
Settings:	0.0 ~ 100.0%	

📖 The setting value of Pr.00-08 Maximum Feedback Pressure is the 100% of this parameter Pr.00-61.

↗ **00-62** Minimum Flow 2

Control mode	VF FOC PG FOC PM	Factory setting: 5.00
	Settings 0.00 ~ 100.00%	

📖 The setting value at Pr.01-02 Maximum Operating Frequency is the 100% of this parameter Pr.00-62.

↗ **00-63** Pressure Releasing Valve Opening Time Interval

Control mode	VF FOC PG FOC PM	Factory setting: 0.100
	Settings 0.000 ~ 0.100 sec	

📖 The output signal MO-46 opens the pressure releasing valve when:

- 1) Speed command is to run reversely,
- 2) Pressure command is to decrease the pressure
- 3) The elapsed time is longer than time set at Pr.00-63.
- 4) The feedback pressure doesn't reach yet the stable pressure zone.

📖 Use Pr.00-63 to set up the time interval between opening and closing pressure releasing valve to avoid unnecessary valve opening and closing (ON / OFF)

00-64
~
00-65 For specific customers only

↗ **00-66** Multi-flow rate / speed command 1

Control mode	VF FOC PG FOC PM	Factory setting: 0
	Settings 0.00 ~ 599.00Hz	

↗ **00-67** Multi-flow rate / speed command 2

Control mode	VF FOC PG FOC PM	Factory setting: 0
	Settings 0.00 ~ 599.00Hz	

↗ **00-68** Multi-flow rate / speed command 3

Control mode	VF FOC PG FOC PM	Factory setting: 0
	Settings 0.00 ~ 599.00Hz	

↗ **00-69** Multi-flow rate / speed command 4

Control mode	VF FOC PG FOC PM	Factory setting: 0
	Settings 0.00 ~ 599.00Hz	

↗	00-70	Multi-flow rate / speed command 5
Control mode	VF FOC PG FOC PM	Factory setting: 0
Settings	0.00 ~ 599.00Hz	

↗	00-71	Multi-flow rate / speed command 6
Control mode	VF FOC PG FOC PM	Factory setting: 0
Settings	0.00 ~ 599.00Hz	

↗	00-72	Multi-flow rate / speed command 7
Control mode	VF FOC PG FOC PM	Factory setting: 0
Settings	0.00 ~ 599.00Hz	

📖 You can set up multi-function input commands (Pr.03-00 to Pr.03-02) to choose different multi-flowrate / speed commands (MI functions #52, #53, #54).

📖 The multi-flow rate / speed commands 1~7 (Pr.00-66 ~ Pr.00-72) correspond to the MI functions (#52, #53, #54) in binary code.

📖 When MI functions #52, #53 and #54 are set to 0, the flowrate command becomes the setting value of Pr.00-45.

📖 Use Pr.00-66 to Pr.00-72 to set up multi-flow rate / speed commands 1~7.

00-73	~ For specific customers only
00-90	

↗	00-91	Output quantity of oil pump
Control mode	VF FOC PG FOC PM	Factory setting: 0
Settings	0 ~ 500cc/rev	

📖 0: Turn off pressure loss detection

📖 To detect if there is a pressure loss.

↗	00-92	Pressure loss detecting time
Control mode	VF FOC PG FOC PM	Factory setting: 0
Settings	0 ~ 60.0 sec	

📖 0: Turn off pressure loss detection

📖 To detect if there is a pressure loss.

📖 The larger the value, the less sensitive to detect the pressure loss. The smaller the value, the more sensitive to detect the pressure loss.

↗	00-93	Pressure limit percentage
Control mode	VF FOC PG FOC PM	Factory setting: 10
Settings	0 ~ 100%	

📖 Pressure limit = Pressure command x Pressure limit %

📖 Set MI =44 as ON, when the pressure error is smaller than the pressure limit, the hybrid servo motor switches to pressure more. When the pressure error is larger than the pressure limit, the hybrid servo drive switches to flowrate mode.

01 Motor Parameters

↗ You can set this parameter during operation.

01-00 Control mode

Control mode	VF	FOCPG	FOCPM	Factory default: 5
			0 : V/F	
			1: Reserved	
			2: Reserved	
Settings			3: FOCPGIM (Induction Motor) (New for HES-C)	
			4: Reserved	
			5: FOCPGPM (Synchronous Motor)	
			6: Reserved	
			7: Reserved	

📖 This parameter determines the control mode of this AC motor.

0: V/F control, the user can design the required V/F ratio. It is used for induction motors.

1: Reserved

2: Reserved

3: FOC vector control + Encoder. It is used for induction motors.

4: Reserved

5: FOC vector control + Encoder. It is used for synchronous motors.

6: Reserved

7: Reserved

↗ 01-01 Source of operation command

Control mode	VF	FOCPG	FOCPM	Factory default: 1
Settings			0: The operation command is controlled by the digital keypad	
			1: The operation command is controlled by the external terminals. The STOP button on the keypad panel is disabled	
			2: The operation command is controlled by RS4845. The STOP button on the keypad panel is disabled	
			03: Reserved	

📖 For the operation command, press the PU button to allow the “PU” indicator to be lit. In this case, the RUN, JOG, and STOP button are enabled.

01-02 Motor’s maximum operating frequency

Control mode	VF	FOCPG	FOCPM	Factory default: Default set at the factory according to the model name
Settings			50.00~599.00Hz	

📖 Set the maximum operation frequency range of the motor. This setting is corresponding to the maximum flow for the system.

📖 When the control mode is FOCPM (Pr01-00=5), Pr00-06 will follow the setting at Pr01-20 <Number of poles of the synchronous motor> to modify Pr01-02<Motor’s maximum operating frequency>. frequency = rpm*Pole/120

01-03 Motor’s rated frequency

Control mode	VF	FOCPG	FOCPM	Factory default: Default set at the factory according to the model name
Settings			0.00~599.00Hz	

📖 Typically, this setting is configured according to the rated voltage and frequency listed in the

specifications on the motor's nameplate. If the motor is intended for 60Hz, set this value as 60Hz; if the motor is intended for 50Hz, set this value as 50Hz.

 The motor's rated frequency will be different as Rated speed of the synchronous motor (Pr01-19) and Number of poles of the synchronous motor (Pr.01-20) change.

01-04 Motor's rated voltage

Control mode	VF	FOCPG	Factory default: 220.0/440.0
Settings	230V models: 0.1~255.0V 460V models: 0.1~510.0V		

 Typically, this setting is configured according to the rated operation voltage shown on the motor's nameplate. If the motor is intended for 220V, set this value as 220.0V; if the motor is intended for 200V, set this value as 200.0V.

01-05 Acceleration time setting

Control mode	VF	FOCPG	FOCPM	Factory default: 0.00
Settings	0.00~600.00 seconds			

01-06 Deceleration time setting

Control mode	VF	FOCPG	FOCPM	Factory default: 0.00
Settings	0.00~600.00 seconds			

 The acceleration time determines the time required for the Hybrid servo motor to accelerate from 0.0Hz to [the motor's maximum frequency] (Pr.01-02). The deceleration time determines the time required for the Hybrid servo motor to decelerate from [the motor's maximum frequency] (Pr.01-02) to 0.0Hz.

01-07 Motor Parameter Auto Tuning

Settings	Factory default: 0			
	Control mode	VF	FOCPG	FOCPM
0: No function		<input type="radio"/>	<input type="radio"/>	
1: Rolling test for induction motor(IM) (Rs, Rr, Lm, Lx, no-load current)		<input type="radio"/>	<input type="radio"/>	
2: Static test for induction motor(IM)		<input type="radio"/>	<input type="radio"/>	
3: Reserved				
4: Auto measure the angle between magnetic pole and PG origin				<input type="radio"/>
5: Parameter measurement by the dynamic test of SPM motor (Surface-mounted Permanent Magnet synchronous Motor)				<input type="radio"/>
9: Angle measurement between magnetic pole and PG origin and parameter measurement by the dynamic test of SPM motor.				
13: Dynamic test for IPM motor (Interior permanent magnet synchronous motor)				
14: Correction of pressure feedback offset				

 If this parameter is set to 5, it will perform the parameter automatic tuning for the synchronous motor. In this case, press the [Run] button to perform the automatic measurement operation immediately. After the measurement is complete, the values are filled into Pr.01-22 (Rs), Pr.01-23 & Pr.01-24 (Ld & Lq), Pr.01-25 (Back EMF of the synchronous motor), respectively.

Synchronous motor *AUTO-Tuning procedure*: (static measurement)

- All parameters of the Hybrid Servo Controller are set to factory settings and the motor is connected correctly.
- Set the rated current Pr.01-17, rated power Pr.01-18, rated speed Pr.01-19, and number

of poles Pr.01-20 of the motor with correct values, respectively. For the acceleration/deceleration time, set the values according to the motor's capacity.

3. Set Pr.01-07 to 5 and then press the RUN button. The auto tuning process for the motor is carried out immediately. (Note: the motor starts running slightly).
4. After the process is finished, check if the motor's parameters (Pr.01-22 ~ Pr.01-25) have been automatically entered with the measurement data.

 If this parameter is set to 4, the automatic measurement of the angle between magnetic pole and the PG origin for the synchronous motor is performed. In this case, press the [Run] button to immediately perform automatic measurement. The measured data will be entered into Pr.01-27.

Auto-Tuning process for Synchronous Motor of the Angle between Magnetic Poles and PG Origin:

1. Set Pr.01-07 as 5 <Rolling test for PM motor> and run this setting. Or input the correct values to Pr.01-03, Pr.01-17 to Pr.01-25.
2. Before tuning, it is recommended to separate the motor and the load.
3. Set Pr.01-07 to 4 and then press the RUN button on the keypad. The auto tuning process for the motor is carried out immediately. (Note: the motor starts running).
4. After the process is complete, check if the values for the angle between magnetic poles and PG origin have been automatically entered in Pr.01-27.

01-08 Rated current of the induction motor (A)

Control mode	FOCPG	Unit: Ampere
		Factory default: ###
	Settings 40~120% of the rated driving current	

 To set this parameter, the user can set the rated motor current range shown on the motor's nameplate. The factory default is 90% of the rated current of the Hybrid Servo Controller.
 For example: For the 7.5HP (5.5kW) motor, the rated current is 25, the factory settings: 22.5A.
 The customers can set the parameter within the range 10 ~ 30A.
 $25 \times 40\% = 10$ $25 \times 120\% = 30$

01-09 Rated power of the induction motor

Control mode	FOCPG	Factory default: ###
	Settings 0 – 655.35kW	

 Set the motor's rated power. The factory default value is the power of the Hybrid Servo Controller.

01-10 Rated speed of the induction motor

Control mode	FOCPG	Factory default: 1710 (60Hz 4-pole) 1410 (50Hz 4-pole)
	Settings 0~65535 rpm	

 This parameter sets the rated speed of the motor. It is necessary to refer to the specifications shown on the motor's nameplate.

01-11 Number of poles of the induction motor

Control mode	FOCPG	Factory default: 4
	Settings 2~20	

 This parameter sets the number of motor number of poles (odd number is not allowed).

01-12 No-load current of the induction motor (A)

Control mode	FOCPG	Unit: Ampere Factory default: #.##
Settings	0~ Default value of Parameter 01-08	

 The factory default is 40% of the rated current of the Hybrid Servo Controller.

01-13 Stator resistance (Rs) of the induction motor

Control mode	FOCPG	Factory default: 0
--------------	-------	--------------------

01-14 Rotor resistance (Rr) of the induction motor

Control mode	FOCPG	Factory default: 0
--------------	-------	--------------------

Settings 0~65.535Ω

01-15 Magnetizing inductance (Lm) of the induction motor

Control mode	FOCPG	Factory default: 0
--------------	-------	--------------------

01-16 Total leakage inductance (Lx) of the induction motor

Control mode	FOCPG	Factory default: 0
--------------	-------	--------------------

Settings 0.0~6553.5mH

01-17 Rated current of the synchronous motor

Control mode	FOCPM	Factory default: Default set at the factory according to the model name.
--------------	-------	--------------------------------------------------------------------------

Settings 0~655.35 Amps

 The user can set the rated current shown on the synchronous motor's nameplate.

01-18 Rated power of the synchronous motor

Control mode	FOCPM	Factory default: Default set at the factory according to the model name.
--------------	-------	--------------------------------------------------------------------------

Settings 0.00 – 655.35kW

 This Parameter sets the rated power of the synchronous motor.

01-19 Rated speed of the synchronous motor

Control mode	FOCPM	Factory default: Default set at the factory according to the model name.
--------------	-------	--------------------------------------------------------------------------

Settings 0~65535

 This parameter sets the rated speed of the synchronous motor. It is necessary to refer to the specifications shown on the motor's nameplate.

01-20 Number of poles of the synchronous motor

Control mode	FOCPM	Factory default: Default set at the factory according to the model name.
--------------	-------	--------------------------------------------------------------------------

Settings 2~20

 This parameter sets the number of the synchronous motor's number of poles (odd number is not allowed).

01-21 Inertia of the synchronous motor's rotor

Control mode

FOCPM

Factory default: Default set at the factory according to the model name.

Settings 0.0~6553.5 *10⁻⁴ kg.m²**01-22 Stator's phase resistance (Rs) oth the synchronous motor**

Control mode

FOCPM

Factory default: Default set at the factory according to the model name.

Settings 0~65.535Ω

 Enter the phase resistance of the synchronous motor.**01-23 stator's phase inductance(Ld) of the synchronous motor****01-24 stator's phase inductance(Lq) of the synchronous motor**

Control mode

FOCPM

Factory default: Default set at the factory according to the model name.

Settings 0.0~655.35mH

 Enter the synchronous motor's phase inductance. For surface type magnets (SPM), Ld = Lq; for built-in magnets (IPM), Ld ≠ Lq.**01-25 Back EMF of the synchronous motor**

Control mode

FOCPM

Factory default: 0

Settings 0~65535 V/krpm

 Enter the back EMF of the synchronous motor.**01-26 Encoder selection**

Control mode

FOCPM

Factory default: 3

Settings

3: Resolver

01-27 Magnetic pole offset angle of the synchronous motor

Control mode

FOCPM

Factory default: 0.0

Settings 0.0~360.0°

 The origin of PG corresponds to the offset angle of the synchronous motor**01-28 Number of poles of the resolver**

Control mode

FOCPM

Factory default: 1

Settings 1~5

01-29 Encoder Pulse

Control mode

FOCPG



FOCPM

Factory default: 1024

Settings 1~20000

 This parameter can be set the encoder's number of pulses per revolution (PPR).

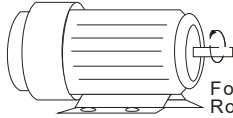
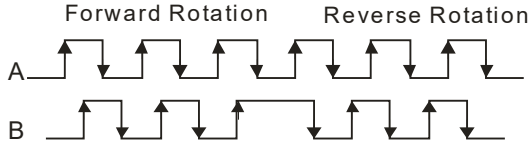
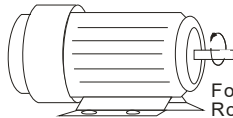
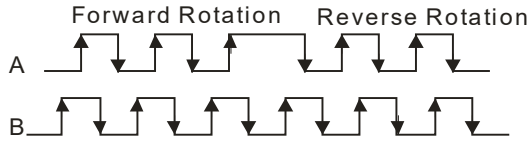
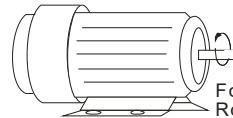
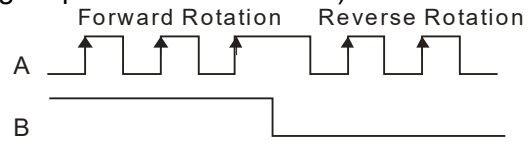
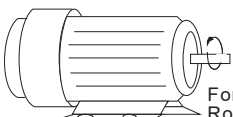
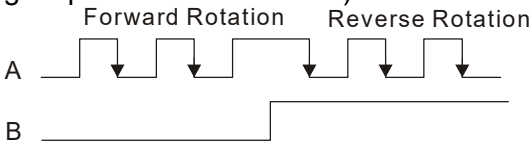
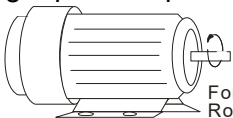
01-30 Encoder's input type setting

Control mode	FOCPG	FOCPM	Factory default: 1
Settings	0: No function 1: Phase A leads in a forward run command and phase B leads in a reverse run command.		
			
			
			
			
			

Enter the correct setting for the pulse type is helpful in controlling the stability.

01-31 System control

Control mode	FOCPG	FOCPM	Factory default: HES-A :1; HES-C:2049; Default set at the factory according to the model name.
Settings	0: No function 1: ASR automatic tuning 2: Estimation of inertia 2049: For HES-C only		

If the setting value is 1: The speed control gain is determined by Parameters 00-10
 If the setting value is 2: The system inertia is estimated. Please refer to descriptions in Chapter 3

01-32 Unity value of the system inertia

Control mode	FOCPG	FOCPM	Factory default: 260
Settings	1~65535 (256 = 1 per unit)		

01-33 Carrier frequency

Control mode	FOCPG	FOCPM	Factory default: 5
Settings	5 kHz; 10kHz		

The carrier frequency of the PWM output has a significant influence on the electromagnetic

noise of the motor. The heat dissipation of the Hybrid Servo Controller and the interference from the environment may also affect the noise. Therefore, if the ambient noise is greater than the motor noise, reducing the carrier frequency of the drive may have the benefits of reducing a temperature rise; if the carrier frequency is high, even if the operation is quiet, the overall wiring and interference control should be taken into consideration.

 When the carrier frequency increases, the rated current decreases as shown in the table below. So the overload capacity also decreases.

Carrier Frequency (kHz)	Rated Current (Pr.00-01)
4	100%
5	100%
6	90%
7	82%
8	75%
9	68%
10	62%

 **01-34** Reserved

01-35 Motor ID

Control mode

FOCPG FOCPM

Factory default: 0

Settings

Delta Hybrid Servo Motor ID		
0	Disabled	
16	ECMA-ER181BP3	11kW220V motor
17	ECMA-KR181BP3	11kW380V motor
18	ECMA-ER221FPS	15kW220V motor
19	ECMA-KR221FPS	15kW380V motor
20	ECMA-ER222APS	20kW220V motor
21	ECMA-ER222APS	20kW380V motor
125	MSJ-KR133AE48B	30kW380V motor
216	MSJ-DR201AE42C	10.4kW220V motor
217	MSJ-IR201AE42C	10.3kW380V motor
218	MSJ-DR201EE43C	14.6kW380V motor
219	MSJ-IR201EE42C	14.2kW380V motor
220	MSJ-DR201IE42C	18.4kW220V motor
221	MSJ-IR201IE42C	18.3kW380V motor
222	MSJ-GR202DE42C	23.1kW220V motor
223	MSJ-OR202DE42C	23kW380V motor
224	MSJ-DR202HE42C	27.6kW220V motor
225	MSJ-LR202FE42C	25kW380V motor
227	MSJ-IR203CE42C	32kW/380V motor
229	MSJ-OR264FE48C	45.2kW380V motor
231	MSJ-IR265CE48C	52.5kW380V motor
233	MSJ-IR266IE48	68kW, 380V motor
245	MSJ-IR202HE42	27kW, 380V motor

02 Parameters for Protection

↗ You can set this parameter during operation.

↗ **02-00** z

Software brake level

Control mode

VF FOC PG FOC PM

Factory default:
380.0/760.0

Settings 230V series: 350.0~450.0V_{DC}
460V series: 700.0~900.0V_{DC}

📖 Sets the reference point of software brake. The reference value is the DC bus voltage.

02-01 Present fault record

02-02 Second most recent fault record

02-03 Third most recent fault record

02-04 Fourth most recent fault record

02-05 Fifth most recent fault record

02-06 Sixth most recent fault record

Settings	Control mode	VF	FOCPG	FOCPM
0: No error record		○	○	○
1: Over-current during acceleration (ocA)		○	○	○
2: Over-current during deceleration (ocd)		○	○	○
3: Over-current during constant speed (ocn)		○	○	○
4: Ground fault (GFF)		○	○	○
5: IGBT short-circuit (occ)		○	○	○
6: Over-current at stop (ocS)		○	○	○
7: Over-voltage during acceleration (ovA)		○	○	○
8: Over-voltage during deceleration (ovd)		○	○	○
9: Over-voltage during constant speed (ovn)		○	○	○
10: Over-voltage at stop (ovS)		○	○	○
11: Low-voltage during acceleration (LvA)		○	○	○
12: Low-voltage during deceleration (Lvd)		○	○	○
13: Low-voltage during constant speed (Lvn)		○	○	○
14: Low-voltage at stop (LvS)		○	○	○
15: Phase loss protection (PHL)		○	○	○
16: IGBT over-heat (oH1)		○	○	○
17: Capacitor over-heat(oH2)		○	○	○
18: TH1 open: IGBT over-heat protection circuit error (tH1o)		○	○	○
19: TH2 open: heat sink over-heat protection circuit error (tH2o) TH2 open: Capacitor over-heat protection circuit error (tH2o)		○	○	○
20: IGBT over heated and unusual fan function (oHF)		○	○	○
21: Hybrid Servo Controller overload (oL)		○	○	○
22: Motor 1 overload (EoL1)		○	○	○
23: Reserved				
24: Hybrid servo motor over-heat(oH3)		○	○	○
25: Reserved				
26: Reserved		○	○	○
27: Reserved		○	○	○
28: Reserved				
29: Reserved				
30: Memory write error (cF1)		○	○	○
31: Memory read error (cF2)		○	○	○
32: Isum current detection error (cd0)		○	○	○
33: U-phase current detection error (cd1)		○	○	○
34: V-phase current detection error (cd2)		○	○	○
35: W-phase current detection error (cd3)		○	○	○
36: Clamp current detection error (Hd0)		○	○	○
37: Over-current detection error (Hd1)		○	○	○

38: Over-voltage current detection error (Hd2)	○	○	○
39: Ground current detection error (Hd3)	○	○	○
40: Auto tuning error (AuE)			○
41: Reserved	○	○	○
42: PG feedback error (PGF1)		○	○
43: PG feedback loss (PGF2)		○	○
44: PG feedback stall (PGF3)		○	○
45: PG feedback slip (PGF4)		○	○
46: Reserved	○	○	○
47: Reserved	○	○	○
48: Reserved			
49: External fault input (EF)	○	○	○
50: Emergency stop (EF1)	○	○	○
51: Reserved			
52: Password input error for 3 consecutive times (PcodE)	○	○	○
53: CPU error (cccod)			
54: Communication error (wrong command) (cE1)	○	○	○
55: Communication error (wrong data address) (cE2)	○	○	○
56: Communication error (wrong data) (cE3)	○	○	○
57: Communication error (wrong data written address) (cE4)	○	○	○
58: RS485 communication time out (cE10)	○	○	○
59: Reserved	○	○	○
60: Braking transistor error (bF)	○	○	○
61~64: Reserved	○	○	○
65: PG card information error (PGF5)			○
66: Over pressure (ovP)	○	○	○
67: Pressure feedback fault (PfbF)	○	○	○
68: Oil pump runs reversely (Prev)			
69: Oil shortage warning (noil)			
70: Reserved			
71: Over current at Braking chopper (ocbs)			
72: Braking resistor is open-circuit (bro)			
73: Resistance of braking resistor is too small (brF)			
74: Braking chopper overheated (oH4)			
75: Error occurred on Brake chopper's thermal protection line (tH4o)			
76~81: Reserved			
82: Output Phase Loss on Phase U (oPL1)			
83: Output Phase Loss on Phase V (oPL2)			
84: Output Phase Loss on Phase W (oPL3)			
85, 86, 88~100: Reserved			
87: Hybrid servo drive overloading while running at low frequency (oL3)			
101: Software error 1 occurred on CANopen (CGdE)			
102: Software error 2 occurred on CANopen (CHbE)			
103: Reserved			
104: Hardware error occurred on CANopen (CbFE)			
105: Index setting error occurred on CANopen (CIdE)			
106: Slave # setting error occurred on CANopen (CAdE)			
107: CANopen index is out of range (CFrE)			

As a fault occurs and the machine is forced shutting down, the event will be recorded. During shutting down, the LvS is not recorded.

02-07 Low voltage level

Control mode	VF	FOCPG	FOCPM	Factory default: 180/360
Settings	230V models: 160.0 – 220.0V _{DC}			
	460V Series: 320 – 440.0V _{DC}			

This parameter is used to set the LV discrimination level.

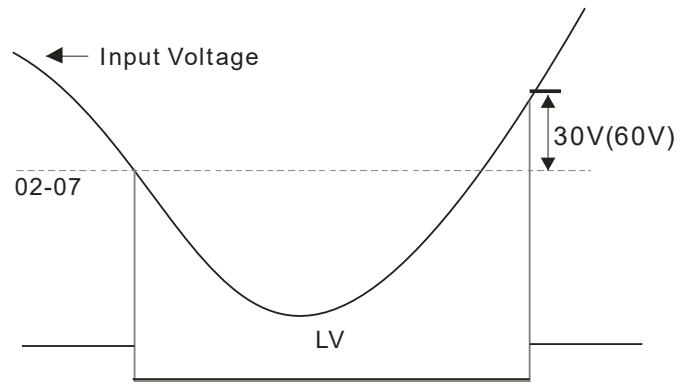

02-08 Motor temperature protection action selection

Control mode	VF	FOCPG	FOCPM	Factory default:
Settings			0: Warn and keep operation 1: Warn and ramp to stop 2: Warn and coast to stop	1

Parameter 02-08 is used to define the operation mode of the drive after the PTC is activated.

02-09 Motor temperature protection level

Control mode	VF	FOCPG	FOCPM	Factory default:
Settings			0.0~150.0% 0.0~150.0°C	HES-A: 120°C HES-C: 140°C

This parameter defines the maximum value of the analog input for 100% of the activation level of the PTC.

02-10 Reserved

02-11 Motor temperature protection type

Control mode	VF	FOCPG	FOCPM	Factory default:
Settings			0: Not assigned 1: KTY84-130 2: PTC100 3: Switch (N.C. model)	1

When this parameter is set to 1: KTY84-130, the unit of Pr02-09 and Pr.02-12 will be changed from % to °C.

.When this parameter is set to 1: KTY84-130, the default setting of Pr.02-09 will change from 50% to HES-A:120°C.. HES-C: 140°C..

There are three types of temperature rising protection: KTY84, PTC and Switch (N.C. model). When you use one of them, wrap the final wires of another type to avoid short-circuiting by touching the wires.

1) When you use KTY84:

Connect the Red/White wire to the T+ connector of I/O terminal on the control board. Then connect the Black/ White wire to the T- connector. And then switch Jumper (J7) to the position of KTY84

2) When you use PTC:

Connect the Yellow wire on encoder to the T+ connector of I/O terminal on the control board.

Then connect the Yellow/Black wire to the T- connector. .

And then switch the Jumper(J7) to the position of OFF

The temperature rising protection by PTC needs to go with the setting at Pr.02-11 =0 and Pr.02-09 PTC level = 62.5%.

(This is a trip-out protection when the motor reaches 130°C)

02-12	Motor fan activation level
Control mode	VF FOC PG FOC PM
Settings	0.0~150.0°C
	Factory default: 50.0

When the Parameters 03-05 to 03-07 for the multi-function output terminal are set to 45, the motor fan will start or stop according to this parameter setting.

02-13	Electronic thermal relay selection 1
Control mode	VF FOC PG FOC PM
Settings	0: Inverter motor 1: Standard motor 2: Disable
	Factory default: 2

02-14	Electronic thermal characteristic for motor
Control mode	VF FOC PG FOC PM
Settings	30.0~600.0 seconds
	Factory default: 60.0

To prevent self-cooled motor from over heating at low speed operation, the user can set the electronic thermal relay to limit the allowed output power of the Hybrid Servo Controller.

02-15	Output frequency at malfunction
Control mode	VF FOC PG FOC PM
Settings	0.00~655.35Hz
	Factory default: Read only

02-16	Output voltage at malfunction
Control mode	VF FOC PG FOC PM
Settings	0.0~6553.5V
	Factory default: Read only

02-17	DC side voltage at malfunction
Control mode	VF FOC PG FOC PM
Settings	0.0~6553.5V
	Factory default: Read only

02-18	Output current at malfunction
Control mode	VF FOC PG FOC PM
Settings	0.00~655.35Amp
	Factory default: Read only

02-19	IGBT temperature at malfunction
Control mode	VF FOC PG FOC PM
Settings	0.0~6553.5°C
	Factory default: Read only

02-20	Auto-reset LvX error
Control mode	VF FOC PG FOC PM
Settings	0: Disable 1: Enable
	Factory setting: 0

When this parameter is enabled and when there is RUN signal, the hybrid servo drive will automatically restart after repowering on.

02-21	Decode the parameter protection with the password
Control mode	
Settings	1~9998
Display	0~3 times of entering wrong password
	Factory setting: 0

- 📖 Enter the password set at Pr02-21 into Pr02-22 to unlock the parameters to make modifications.
- 📖 Write down the setting value after you set up this parameter to avoid inconveniences.
- 📖 Use Pr02-21 and Pr02-22 to prevent any unauthorized personnel to modify/ delete parameters.
- 📖 If you forget the password, input 9999 and press ENTER, then repeat inputting 9999 and pressing ENTER to complete the decoding procedure (This procedure has to be done in 10 seconds, if you don't finish that in 10 seconds, repeat the same procedure until you finish the procedure in 10 sec.). Once you finish this decoding process, all the parameters will be back to the factory settings.
- 📖 When setting up a password, all the parameters will be read as 0, except Pr02-22.

⚡ **02-22 Set up a parameter protection password**

Control mode

Factory setting: 0

Settings 1~ 9998, 10000~65535

Display 0: No password set or password entered successfully in Pr02-30.

1: Parameters are locked

- 📖 This parameter is for setting up a password to protect parameters. When you finish setting up a password, keypad will display 1, which means the password protection is now effective.
- 📖 Once you input the correct password into Pr.02-21, the hybrid servo drive is temporarily unlocked. To cancel the parameter protection, set Pr.02-22 =0. Once the parameter protection is cancelled, the hybrid servo drive is without password protection even after reboot.
- 📖 Decode temporarily or cancel the password then you will be able to use keypad to copy parameters. But the password set at Pr.02-22 will not be copied. When the parameters saved in the keypad are transferred to the hybrid servo drive, you will need to set up a password at Pr.02-22 to enable parameter protection.

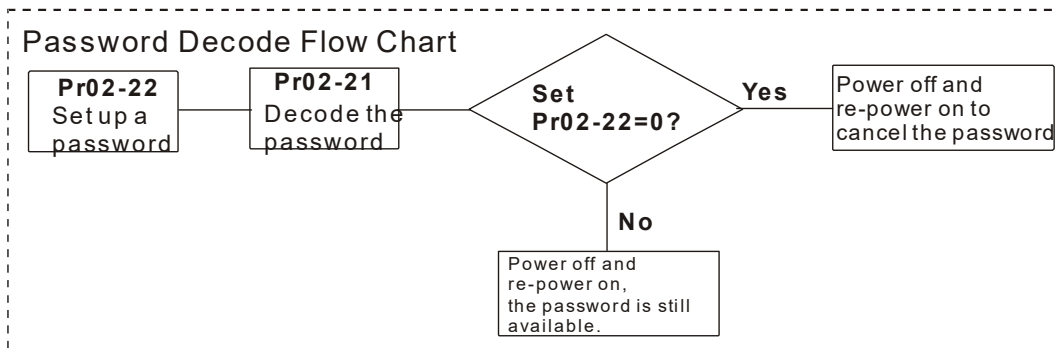
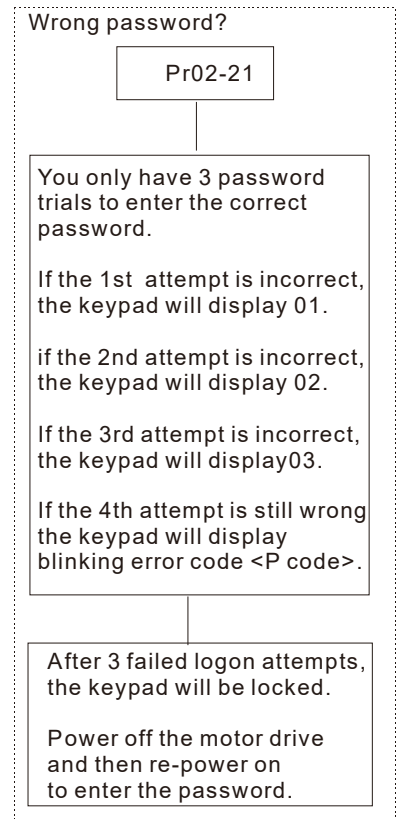
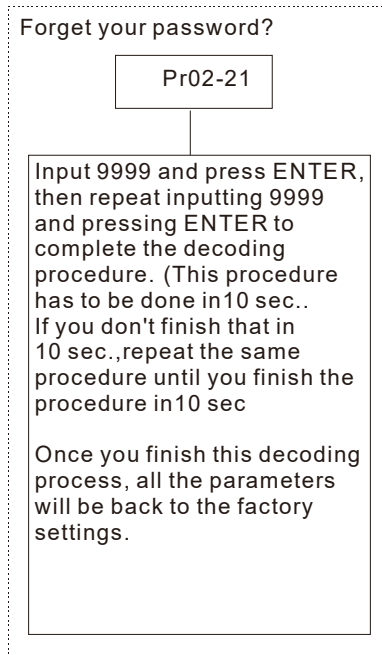
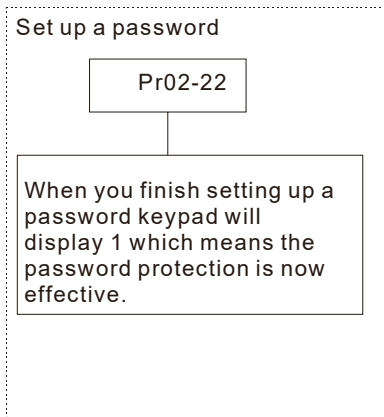





02-23 ~ 02-31 Reserved

02-32	Frequency command at malfunction	Control mode VF FOC PG FOC PM Settings 0.00 – 599.00Hz	Factory setting: Read only
02-33	Capacitors' temperature at malfunction	Control mode VF FOC PG FOC PM Settings -3276.7~3276.7°C	Factory setting: Read only
02-34	Motor's rotating speed at malfunction	Control mode VF FOC PG FOC PM Settings -32767~32767rpm	Factory setting: Read only
02-35	Torque command at malfunction	Control mode VF FOC PG FOC PM Settings -32767~32767%	Factory setting: Read only
02-36	Input terminals status at malfunction	Control mode VF FOC PG FOC PM Settings 0~65535	Factory setting: Read only

02-37	Output terminals status at malfunction	
Control mode	VF FOC PG FOC PM	Factory setting: Read only
Settings	0~65535	
02-38	Hybrid servo drive status at malfunction	
Control mode	VF FOC PG FOC PM	Factory setting: Read only
Settings	0~65535	



02-39	Detecting Braking Resistor at startup	
Control mode	VF FOC PG FOC PM	Factory setting: 1
Settings	0: Disable 1: Enable	

02-40	Braking resistance	
Control mode	VF FOC PG FOC PM	Factory setting: 0.0
Settings	0.0 ~ 6553.5Ω	



-  Set Pr.02-39 =1 (Enable detection of braking resistor at startup), then as soon as the hybrid servo drive is powered on, a checkup will be performed to know if the braking resistance is appropriate and if the braking resistor is working properly.
-  If the braking resistance is too small, the braking resistor could be on an open circuit or is not properly installed. The error code <bro> will be displayed on the keypad.
-  If the braking resistance is smaller than the allowable minimum resistance or is on a short circuit, the error code <brF > or <ocbS> will be displayed on the keypad.
-  Pr.02-40 is the detected braking resistance.

02-41	Limit of current	
Control mode	FOC PG FOC PM	Factory setting: 200
Settings	0 ~ 250%	

02-42	Maintenance period of the soft-start relay	
Settings	0~65535(x10)	Factory setting: 0
	0: Disable the reminder of the remaining lifetime of the soft-start relay.	

-  Soft-start relay start relay reminds the remaining lifetime by counting the number of times of Relay ON. Then compare this number to the setting at Pr.02-42. And then the warning code (L.rEL) pops up..
-  Troubleshooting: Set Pr00-02 = 21 < Reset counting time.> or set Pr.02-42 = 0 to disable this warning.

02-43	Maintenance period of the cooling fan	
Settings	0~65535 hour	Factory setting: 0
	0: Disable the reminder of the remaining maintenance hour of the cooling fan.	

-  The cooling fan maintenance reminder. By calculating the running time of the cooling fan. Then when the length of time has reached the time set at Pr.02-43, the warning code (S.FAn) pops up.
-  Troubleshooting: Set Pr.00-02 = 21 < Reset counting time.> or set Pr.02-43 = 0 to diable this warning.

03 Digital/Analog Input/Output Parameters

✎ You can set this parameter during operation.

03-00	Multi-function input command 3 (MI3)			
03-01	Multi-function input command 4 (MI4)			
03-02	Multi-function input command 5 (MI5)			
Control mode	VF	FOCPG	FOCPM	Factory default: 0
Settings		0: No function 44: Injection signal input 45: Confluence/Diversion signal input 46: Reserved 47: Multi-level pressure PI command 1 48: Multi-level pressure PI command 2 51: flow rate mode		

- 📖 When this parameter is set to 44, the pressure error is bigger than the pressure limit percentage (Pr.00-93), the controller carry out flow rate control. But when it is smaller than the pressure percentage limit, the controller does the pressure control..
- 📖 If the setting value is 45, the confluence (OFF)/diversion (ON) function will be performed. For detailed operation, please refer to Chapter 2 for wiring and Chapter 3 for tuning.
- 📖 New protection mechanism of HES-C: When Pr.03-00, Pr.03-01 and Pr.03-02 are set to 45, Pr.01-01 is automatically set to 2 and Pr.03-15 is automatically set to 1. This mechanism is to prevent users from forgetting to make settings or make wrong settings.
- 📖 Please refer to the description Pr.00-36 if the setting value is 47 and 48,
- 📖 When Pr.00-09 is set to 1 <Pressure Control>, Pr.03-00, Pr.03-01 and Pr.03-02 are set to 51 <Flow rate mode>and the external terminal is ON, the speed command is the flow rate command. It is no longer necessary to learn what the flow command is through the calculation of PI pressure.

✎ 03-03	Digital input response time			
Control mode	VF	FOCPG	FOCPM	Factory default: 0.005
Settings		0.001~30.000 sec		

- 📖 This parameter is used to delay and confirm the signal on the digital input terminal.

✎ 03-04	Digital input operation direction			
Control mode	VF	FOCPG	FOCPM	Factory default: 0
Settings		0~65535		

- 📖 This parameter defines the activation level of the input signal.
- 📖 Bit 0 for the SON terminal, bit 2 for the EMG terminal, bit 3 for the RES terminal, bits 4~6 correspond to MI3~MI5, respectively.

✎ 03-05	Multi-function output 1 (Relay 1)			
Control mode	VF	FOCPG	FOCPM	Factory default: 11

✎ 03-06	Multi-function Output 2 (MO1)			
Control mode	VF	FOCPG	FOCPM	Factory default: 0

✎ 03-07	Multi-function Output 3 (MO2)			
Control mode	VF	FOCPG	FOCPM	Factory default: 0
Settings		0: No function 1: Operation indication 9: Hybrid Servo Controller is ready		

11: Error indication
 14: MO1 software brake output
 44: Displacement switch signal
 45: Motor fan control signal
 46: Pressure release valve control signal

03-08 Multi-function output direction

Control mode	VF	FOCPG	FOCPM	Factory default: 0
Settings	0~65535			

This parameter is used for bit-wise setting. If the corresponding bit is 1, the multi-function output is set as reverse direction.

03-09 Low-pass filtering time of keypad display

Control mode	VF	FOCPG	FOCPM	Factory default: 0.100
Settings	0.001~65.535 seconds			

This parameter can be set to reduce the fluctuation of the readings on the keypad.

03-10 Maximum output voltage for pressure feedback

Control mode	VF	FOCPG	FOCPM	Factory default: 10.0
Settings	5.0~10.0 V			

03-11 Minimum output voltage for pressure feedback

Control mode	VF	FOCPG	FOCPM	Factory default: 0.0
Settings	0.0~2.0V			

This parameter defines the pressure feedback output voltage type.

If the pressure feedback has a bias, can adjust this parameter to eliminate the bias.

03-12 Type of Pressure Feedback Selection

Control mode	VF	FOCPG	FOCPM	Factory default: 1
Settings	0: Current 1: Voltage			

VJ-C: PS (Pressure Feedback) terminal: Add a current-fed pressure feedback (4~20mA)

The following are required when using it:

Switch the SW100 on the I/O board to "PS-I". (As shown in the image below.)



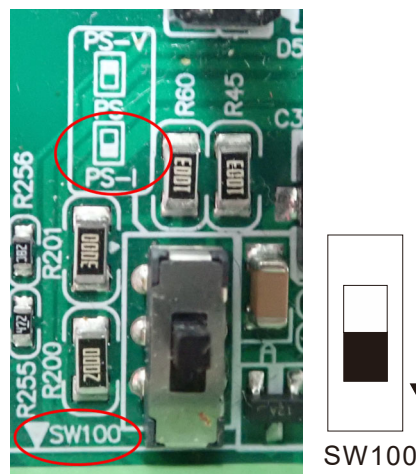

Set Pr.03-12 = 0 (4~20mA)

Set Pr.00-36 = 1 (Enable detection of the pressure feedback disconnection)





03-13 Confluence Master/Slave Selection

Control mode	VF	FOCPG	FOCPM	Factory default: 0
Settings		0: No function		
		1: Master 1		
		2: Slave/Master 2		
		3: Slave/Master 3		

-  In a stand-alone system, this parameter is set as 0
-  In a confluence system, the parameter is set as 1 for the Master and 2 for the Slave
-  With multi-function input terminal function 45, the confluence/diversion can be configured. For detailed operation, please refer to Chapter 2 for wiring and Chapter 3 for tuning.
-  The difference between Master 2 and Master 3 is that the Master 3 can be configured as confluent with other Slaves during confluence; however, the Master 2 can be configured for stand-alone operation.
-  When Pr.03-13 is set as 2: Slave, at the same time, Pr.01-01 will be set as 2 and Pr.03-15 will be set as 1 automatically.



03-14 Slave's proportion of the Master's flow

Control mode	VF	FOCPG	FOCPM	Factory default: 100.0
Settings		0.0~65535.5 %		

-  This parameter setting is required only for the Master but not needed for the Slave.
-  In a confluence system, this parameter value defines the Slave's portion of the Master's flow.
Example: Slave is 60L/min and Master is 40L/min, so the setting is $60/40 * 100\% = 150\%$
For confluence of more than 2 pumps, the values for the slaves must be the same. For example, if the total flow for a three-pump system is 200L/min, where the Master is 40L/min, then the two Slaves should be 80L/min. The setting of Parameter 03-14 should be $160/40 = 400\%$

03-15 Source of frequency command

Control mode	VF	FOCPG	FOCPM	Factory default: 0
Settings		0: Digital Operation Panel		
		1: RS485 Communication		
		2~5: Reserved		
		6: CANopen (new for VJ-C)		

-  EMVJ-MF01 is not required for VJ-C
-  In a confluence system, if the Slave's frequency command is given through the RS485 communication, the setting value should be 1.



03-16 Limit for the Slave reverse depressurization torque

Control mode	VF	FOCPG	FOCPM	Factory default: 20
Settings		0~500%		

-  Set the torque limit of the Slave when running reversely

03-17 Slave's activation level

Control mode	VF	FOCPG	FOCPM	Factory default: 50
Settings		0~100%		

-  This parameter setting is required only for the Master but not needed for the Slave.
-  This parameter determines the activation level for the Slave. A 100% value corresponds to the full flow of the Master.

03-18 Reserved**03-19** Reserved**03-20 Start-up display selection**

Control mode	VF	FOCPG	FOCPM	Factory default: 0
Settings		0: F (frequency command)		
		1: H (actual frequency)		
		2: Multi-function display (user-defined 00-04)		
		3: A (Output current)		

 This parameter is used to set the contents of the start-up screen. The content of the user-defined option is displayed in accordance with the setting value of Parameter 00-04.

03-21 Slave reverse operation for depressurization

Control mode	VF	FOCPG	FOCPM	Factory default: 0
Settings		0: Disabled		
		1: Enabled		

 This parameter setting is required only for the Slave but not needed for the Master.

 When the parameter is set as 1, it is necessary to make sure that the outlet end of the Slave is not installed with any one-way valve and the parameter 03-16 is set as 500.

03-22 Slave closing level

Settings	0~ 400 Bar	Factory setting: 400
----------	------------	----------------------

 Set up this parameter from a Master. The slave pump(s) will be shut down when the master pump detects the pressure higher than the setting value at this parameter. The slave pump(s) will resume to run after the hybrid servo drive goes into stand by.

04 Communication Parameters

✎ You can set this parameter during operation.

The communication port is defined as shown in the figure on the right. We recommend using Delta IFD6500 or IFD6530 as your communication converter between the hybrid servo drive and your computer. See wiring diagram in Ch02 to know the position of this communication port.

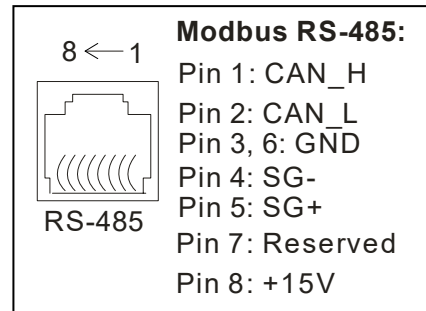

✎ **04-00** COM1 Communication Address Factory Setting: 1

Settings 1~254

📖 If the hybrid servo drive is controlled by RS-485 serial communication, the communication address for this drive must be set via this parameter and each hybrid servo drive's communication address must be different.

✎ **04-01** COM1 Transmission Speed Factory Setting: 19.2

Settings 4.8~115.2 Kbps

📖 This parameter is for setting up the transmission speed of computer and the hybrid servo drive.

📖 Please set 4.8 Kbps, 9.6 Kbps, 19.2 Kbps, 38.4 Kbps, 57.6 Kbps, or 115.2 Kbps. Otherwise the transmission speed will be replaced by 19.2 Kbps.

✎ **04-02** COM1 Transmission Fault Treatment Factory Setting: 3

Settings 0: Warn and keep operation
 1: Warn and ramp to stop
 2: Warn and coast to stop
 3: No warning and continue operation

📖 This parameter is to set the response to the transmission errors such as a disconnection.

✎ **04-03** COM1 Time-out Detection Factory Setting: 0.0

Settings 0.0~100.0 sec.

📖 Use this parameter to set the communication transmission time-out.

04-04 COM1 Communication Protocol

Factory Setting: 13

- Settings
- 0) 7, N, 1 for ASCII
 - 1) 7, N, 2 for ASCII
 - 2) 7, E, 1 for ASCII
 - 3) 7, O, 1 for ASCII
 - 4) 7, E, 2 for ASCII
 - 5) 7, O, 2 for ASCII
 - 6) 8, N, 1 for ASCII
 - 7) 8, N, 2 for ASCII
 - 8) 8, E, 1 for ASCII
 - 9) 8, O, 1 for ASCII
 - 10) 8, E, 2 for ASCII
 - 11) 8, O, 2 for ASCII)
 - 12) 8, N, 1 for RTU)
 - 13) 8, N, 2 for RTU
 - 14) 8, E, 1 for RTU
 - 15) 8, O, 1 for RTU
 - 16) 8, E, 2 for RTU
 - 17) 8, O, 2 for RTU

Control by PC (Computer Link)

When using RS-485 serial communication interface, each drive must be pre-specified its communication address in Pr.09-00, the computer can implement control according to their individual address.

 Modbus ASCII (American Standard Code for Information Interchange): Each byte data is the combination of two ASCII characters. For example, a 1-byte data: 64 Hex, shown as '64' in ASCII, consists of '6' (36Hex) and '4' (34Hex).

1. Code Description

Communication protocol is in hexadecimal, ASCII: "0" ... "9", "A" ... "F", every 16 hexadecimal represent ASCII code. For example:

Character	'0'	'1'	'2'	'3'	'4'	'5'	'6'	'7'
ASCII code	30H	31H	32H	33H	34H	35H	36H	37H

Character	'8'	'9'	'A'	'B'	'C'	'D'	'E'	'F'
ASCII code	38H	39H	41H	42H	43H	44H	45H	46H

2. Data Format

10-bit character frame (For ASCII):

(7, N, 2)

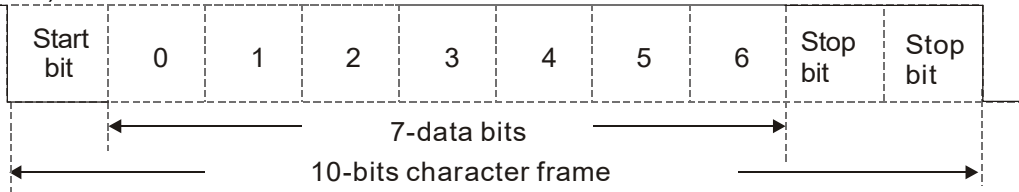

(7, E, 1)

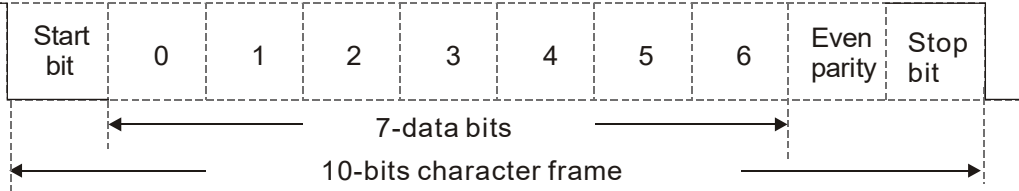

(7, O, 1)

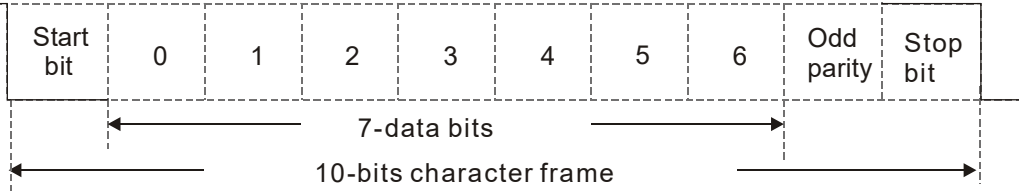

11-bit character frame (For RTU):

(8, N, 2)

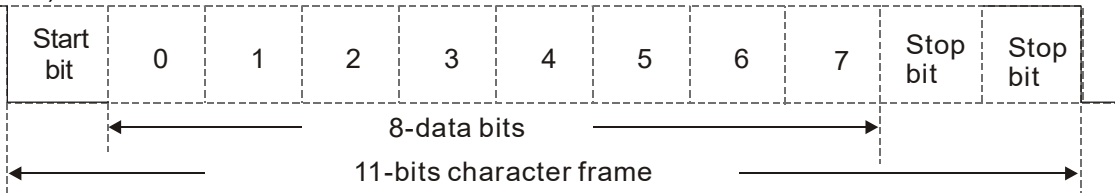

(8, E, 1)

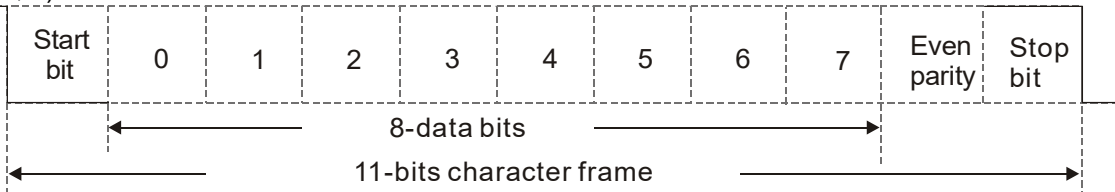

(8, O, 1)

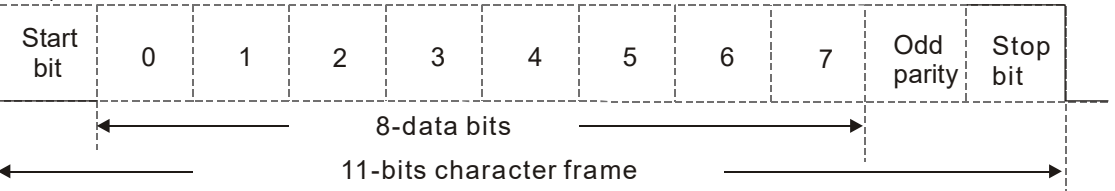

3. Communication Protocol

Communication Data Frame

ASCII mode :

STX	Start character = ':' (3AH)
Address Hi	Communication address: 8-bit address consists of 2 ASCII codes
Address Lo	
Function Hi	Command code: 8-bit command consists of 2 ASCII codes
Function Lo	
DATA (n-1)	Contents of data: N x 8-bit data consist of 2n ASCII codes N ≤ 16, maximum of 32 ASCII codes (20 sets of data)
.....	
DATA 0	
LRC CHK Hi	LRC check sum: 8-bit check sum consists of 2 ASCII codes
LRC CHK Lo	
END Hi	End characters: END Hi = CR (0DH), END Lo = LF (0AH)
END Lo	

RTU mode:

START	A silent interval of more than 10 ms
Address	Communication address: 8-bit address
Function	Command code: 8-bit command
DATA (n-1)	Contents of data: N × 8-bit data, n ≤ 16
.....	
DATA 0	
CRC CHK Low	CRC check sum: 16-bit check sum consists of 2 8-bit characters
CRC CHK High	
END	A silent interval of more than 10 ms

Communication Address (Address)

00H: broadcast to all hybrid servo drives

01H: hybrid servo drive of address 01

0FH: hybrid servo drive of address 15

10H: hybrid servo drive of address 16

:

FEH: Hybrid servo drive of address 254

Function code (Function) and DATA (Data characters)

03H: read data from register

06H: write single register

Example: reading continuous 2 data from register address 2102H, AMD address is 01H.

ASCII mode:

Command Message:		Response Message	
STX	'.'	STX	'.'
Address	'0'	Address	'0'
	'1'		'1'
Function	'0'	Function	'0'
	'3'		'3'
Starting register	'2'	Number of register (count by byte)	'0'
	'1'		'4'
	'0'	Content of starting register 2102H	'1'
	'2'		'7'
Number of register (count by word)	'0'	Content of register 2103H	'7'
	'0'		'0'
	'0'		'0'
	'2'		'0'
LRC Check	'D'	LRC Check	'0'
	'7'		'0'
END	CR	END	'7'
	LF		'1'
			CR
			LF

RTU mode:

Command Message:		Response Message	
Address	01H	Address	01H
Function	03H	Function	03H
Starting data register	21H	Number of register (count by byte)	04H
	02H		
Number of register (count by world)	00H	Content of register address 2102H	17H
	02H		70H
CRC CHK Low	6FH	Content of register address 2103H	00H
CRC CHK High	F7H		00H
		CRC CHK Low	FEH
		CRC CHK High	5CH

06H: single write, write single data to register.

Example: writing data 6000 (1770H) to register 0100H. AMD address is 01H.

ASCII mode:

Command Message:		Response Message	
STX	‘:’	STX	‘:’
Address	‘0’	Address	‘0’
	‘1’		‘1’
Function	‘0’	Function	‘0’
	‘6’		‘6’
Target register	‘0’	Target register	‘0’
	‘1’		‘1’
	‘0’		‘0’
	‘0’		‘0’
Register content	‘1’	Register content	‘1’
	‘7’		‘7’
	‘7’		‘7’
	‘0’		‘0’
LRC Check	‘7’	LRC Check	‘7’
	‘1’		‘1’
END	CR	END	CR
	LF		LF

RTU mode:

Command Message:		Response Message	
Address	01H	Address	01H
Function	06H	Function	06H
Target register	01H	Target register	01H
	00H		00H
Register content	17H	Register content	17H
	70H		70H
CRC CHK Low	86H	CRC CHK Low	86H
CRC CHK High	22H	CRC CHK High	22H

10H: write multiple registers (write multiple data to registers) (at most 20 sets of data can be written simultaneously)

Example: Set the multi-stage speed of hybrid servo drive (address is 01H):

Pr.04-00 = 50.00 (1388H), Pr.04-01 = 40.00 (0FA0H)

ASCII Mode

Command Message:		Response Message	
STX	':'	STX	':'
ADR 1	'0'	ADR 1	'0'
ADR 0	'1'	ADR 0	'1'
CMD 1	'1'	CMD 1	'1'
CMD 0	'0'	CMD 0	'0'
Target register	'0'	Target register	'0'
	'5'		'5'
	'0'		'0'
Number of register (count by word)	'0'	Number of register (count by word)	'0'
	'0'		'0'
	'2'		'2'
Number of register (count by Byte)	'0'	LRC Check	'E'
	'4'		'8'
The first data content	'1'	END	CR
	'3'		LF
	'8'		
The second data content	'0'		
	'F'		
	'A'		
LRC Check	'9'		
	'A'		
END	CR		
	LF		

RTU mode:

Command Message:		Response Message:	
ADR	01H	ADR	01H
CMD	10H	CMD 1	10H
Target register	05H	Target register	05H
	00H		00H
Number of register (Count by word)	00H	Number of register (Count by word)	00H
	02H		02H
Quantity of data (Byte)	04	CRC Check Low	41H
The first data content	13H	CRC Check High	04H
	88H		
The second data content	0FH		
	A0H		
CRC Check Low	'9'		
CRC Check High	'A'		

Check sum

ASCII mode:

LRC (Longitudinal Redundancy Check) is calculated by summing up, module 256 and the values of the bytes from ADR1 to last data character then calculating the hexadecimal representation of the 2's-complement negation of the sum.

For example:

01H + 03H + 21H + 02H + 00H + 02H = 29H, the 2's-complement negation of 29H is **D7H**.

RTU mode:

CRC (Cyclical Redundancy Check) is calculated by the following steps:

Step 1: Load a 16-bit register (called CRC register) with FFFFH.

- Step 2:** Exclusive OR the first 8-bit byte of the command message with the low order byte of the 16-bit CRC register, putting the result in the CRC register.
- Step 3:** Examine the LSB of CRC register.
- Step 4:** If the LSB of CRC register is 0, shift the CRC register one bit to the right with MSB zero filling, then repeat step 3. If the LSB of CRC register is 1, shift the CRC register one bit to the right with MSB zero filling, Exclusive OR the CRC register with the polynomial value A001H, then repeat step 3.
- Step 5:** Repeat step 3 and 4 until eight shifts have been performed. When this is done, a complete 8-bit byte will be processed.
- Step 6:** Repeat step 2 to 5 for the next 8-bit byte of the command message. Continue doing this until all bytes are processed. The final contents of the CRC register are the CRC value. When transmitting the CRC value in the message, the upper and lower bytes of the CRC value must be swapped, i.e. the lower order byte will be transmitted first.

The following is an example of CRC generation using C language. The function takes two arguments:

Unsigned char* data ← a pointer to the message buffer

Unsigned char length ← the quantity of bytes in the message buffer

The function returns the CRC value as a type of unsigned integer.

```
Unsigned int crc_chk(unsigned char* data, unsigned char length)
{
    int j;
    unsigned int reg_crc=0Xffff;
    while(length--){
        reg_crc ^= *data++;
        for(j=0;j<8;j++){
            if(reg_crc & 0x01){ /* LSB(b0)=1 */
                reg_crc=(reg_crc>>1) ^ 0Xa001;
            }else{
                reg_crc=reg_crc >>1;
            }
        }
    }
    return reg_crc;                // return register CRC
}
```

4. Address list

Content	Register	Function	
Hybrid servo drive parameters	GGnnH	GG means parameter group, nn means parameter number, for example, the address of Pr.04-01 is 0401H.	
Command write only	2000H	bit 1~0	00B: No function
			01B: Stop
			10B: Run
			11B: Enable JOG
		bit 3~2	Reserved
		bit 5~4	00B: No function
			01B: FWD
	10B: REV		
	bit 14~13	00B: No function	
		01B: Operated by digital keypad	
		10B: Operated by Pr.00-21	
	bit 15	Reserved	
	2001H	Frequency command(Set Pr.00-06=0, Input XXX.XX Hz)	
2002H	bit 0	1: EF (external fault) on	
	bit 1	1: Reset	
	bit 2	1: B.B ON	
	bit 15~3	Reserved	
Status monitor read only	2100H	High byte: Warn code Low Byte: Error code	
	2101H	bit 1~0	Hybrid servo drive operation status
			00B: Drive stops 01B: Drive decelerating 10B: Drive standby 11B: Drive in operation
		bit 2	1: Reserved
	bit 4~3	Operation direction	
00B: FWD run 01B: From REV run to FWD run 10B: From FWD run to REV run 11B: REV run			
		bit 8	1: Master frequency controlled by communication interface
		bit 9	1: Master frequency controlled by analog signal or external input terminals.
		bit 10	1: Operation command controlled by communication interface
		bit 11	1: Parameter locked
		bit 12~15	Reserved
	2102H	Frequency command (XXX.XX Hz)	
	2103H	Output frequency (XXX.XX Hz)	
	2104H	Output current (XX.XX A).	
	2105H	DC bus voltage (XXX.X V)	
	2106H	Output voltage (XXX.X V)	
	2107H	Reserved	
	2108H	Reserved	
	2116H	Multi-function display (Pr.00-04)	
	2200H	Display output current (A)	
	2201H	Reserved	
2202H	Actual output frequency (XXX.XX Hz)		
2203H	DC bus voltage (XXX.X V)		
2204H	Output voltage (XXX.X V)		
2205H	Power angle (XXX.X)		
2206H	Display actual motor speed kW of U, V, W (XXXXX kW)		
2207H	Display motor speed in rpm estimated by the drive or encoder		

Content	Register	Function
		feedback (XXXXX rpm) (Pr.00-04 #7)
	2208H	Display positive / negative output torque in %, estimated by the motor drive (t0.0: positive torque, -0.0: negative torque) (XXX.X %) (Pr.00-04 #8)
	2209H	Display PG feedback (Pr.00-04 #9)
	220AH	Reserved
	220BH	Display the signal value of the analog input terminal PS with 4~20mA/ 0~10V mapped to 0~100%
	220CH	Display the signal value of the analog input terminal PI with 0~10V mapped to 0~100%
	220DH	Display the signal value of the analog input terminal AUI with -10~10V mapped to -100~100%
	220EH	Display the temperature of the power module IGBT (XXX.X °C)
	220FH	Display the temperature of the power capacitor (XXX.X °C)
	2210H	Display the status of digital input (ON / OFF)
	2211H	Display the status of digital output (ON / OFF)
	2212H	Reserved
	2213H	The corresponding CPU pin status of digital input (d.)
	2214H	The corresponding CPU pin status of digital output (O.)
	2215H	Reserved
	2216H	Reserved
	2217H	Reserved
	2218H	Reserved
	2219H	Display the signal value of the analog input terminal QI with 0~10V mapped to 0~100%
	221AH	Display the actual pressure value (XXX.X Bar)
	221BH	Display the kWh value (XXX.X kWh)
	221CH	Display the motor temperature (XXX.X °C)
	221DH	Over load rate of hybrid servo drive (XXX.X %)
	221EH	Over load rate of motor with last digit A of HES (XXX.X %)
	221FH	Display current at braking (XXX A)
	2220H	Display temperature of the braking chopper (XXX.X °C)

5. Exception response:

When drive is doing communication connection, if an error occurs drive will respond the error code and set the highest bit (bit 7) of code to 1 (function code AND 80H) then response to control system to know that an error occurred.

If keypad displays “CE-XX” as a warning message, “XX” is the error code at that time. Please refer to the meaning of error code in communication error for reference.

Example:

ASCII mode:		RTU mode:	
STX	‘.’	Address	01H
Address	‘0’	Function	86H
	‘1’	Exception code	02H
Function	‘8’	CRC CHK Low	C3H
	‘6’	CRC CHK High	A1H
Exception code	‘0’		
	‘2’		
LRC CHK	‘7’		
	‘7’		
END	CR		
	LF		

The explanation of exception codes:

Exception code	Explanation
1	Function code is not supported or unrecognized.
2	Address is not supported or unrecognized.
3	Data is not correct or unrecognized.
4	Fail to execute this function code

04-05 Delay Time of Communication Response Factory Setting: 2.0

Settings 0.0~200.0 ms

This parameter is the response delay time after hybrid servo drive receives communication command as shown in the following.

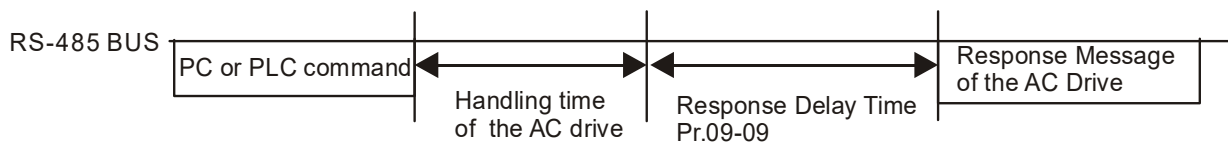

04-06 Main Frequency of the Communication Factory Setting: 60.00

Settings 0.00~599.00 Hz

When Pr.00-20 is set to 1 (RS-485 communication). The hybrid servo drive will save the last frequency command at Pr.04-06 when abnormal turn-off or momentary power loss.

After rebooting the power, if no new frequency command is given, the hybrid servo drive will continue to run by using the frequency set at Pr.04-06.

↗	04-07	Block Transfer 1
↗	04-08	Block Transfer 2
↗	04-09	Block Transfer 3
↗	04-10	Block Transfer 4
↗	04-11	Block Transfer 5
↗	04-12	Block Transfer 6
↗	04-13	Block Transfer 7
↗	04-14	Block Transfer 8
↗	04-15	Block Transfer 9
↗	04-16	Block Transfer 10

Factory Setting: 0.00

Settings 0.00~655.35

 There is a group of block transfer parameter available in the hybrid servo drive (Pr.04-07 to Pr.04-16). Through communication code 03H, you can use them (Pr.04-07 to Pr.04-16) to save those parameters that you want to read.

04-17 CANopen Slave Address

Factory Setting: 0

Settings 0: Disable
1~127**04-18** CANopen Speed

Factory Setting: 0

Settings 0) 1 Mbps
1) 500 kbps
2) 250 kbps
3) 125 kbps
4) 100 kbps (Delta only)
5) 50 kbps**04-19** CANopen Warning Record

Factory Setting: 0

Settings bit 0: CANopen software disconnection 1 (CANopen Guarding Time out)
bit 1: CANopen software disconnection 2 (CANopen Heartbeat Time out)
bit 2: CANopen SYNC time out
bit 3: CANopen SDO time out
bit 4: CANopen SDO buffer overflow
bit 5: CANopen hardware disconnection warning (CAN bus Off)
bit 6: Error protocol of CANopen
bit 8: The setting values of CANopen indexes fail.
bit 9: The setting value of CANopen address fails.
bit10: The checksum value of CANopen indexes fail.

04-20 CANopen Decoding Method

Factory Setting: 1

- Settings 0: Delta defined decoding method
1: CANopen Standard DS402 protocol

04-21 CANopen Communication Status

Factory Setting: Read Only

- Settings 0: Node Reset State
1: Com Reset State
2: Boot up State
3: Pre Operation State
4: Operation State
5: Stop State

04-22 CANopen Control Status

Factory Setting: Read Only

- Settings 0: Not ready for use state
1: Inhibit start state
2: Ready to switch on state
3: Switched on state
4: Enable operation state
7: Quick stop active state
13: Error reaction activation state
14: Error state

04-23 Reserved

04-24 Communication Decoding Method

Factory Setting: 1

- Settings 0: Decoding method 1
1: Decoding method 2

		Decoding Method 1	Decoding Method 2
Source of Operation Control	Digital Keypad	Digital keypad controls the drive action regardless decoding method 1 or 2.	
	External Terminal	External terminal controls the drive action regardless decoding method 1 or 2.	
	RS-485	Refer to address: 2000h~20FFh	Refer to address: 6000h ~ 60FFh
	CANopen	Refer to index: 2020-01h~2020-FFh	Refer to index:2060-01h ~ 2060-FFh

Chapter 5 Methods of Anomaly Diagnosis

5-1 Unusual signal

5-2 Dynamic fault processing and troubleshooting

5-3 Resolution for electromagnetic noise and induction noise

5-4 Environment and facilities for installation

5-5 Common Problems, Diagnosis and Troubleshooting

The hybrid servo controller is capable of displaying warning messages such as over voltage, low voltage, and over current and equipped with the protection function. Once any malfunction occurs, the protection function will be enabled and the hybrid servo controller will stop its input, followed by the action of the anomaly connection point and stopping of the servo oil pump. Please refer to the cause and resolution that corresponds to the error message displayed by the hybrid servo controller for troubleshooting. The error record will be stored in the internal memory of the hybrid servo controller (up to the last six error messages) and can be read by the digital keypad or communication through parametric readout.



- Upon the occurrence of anomaly, wait for five seconds after the anomaly is resolved before pressing the RESET key.
- Verify that the power indicator is off before opening the machine cover and starting the inspection.

5-1 Unusual Signal

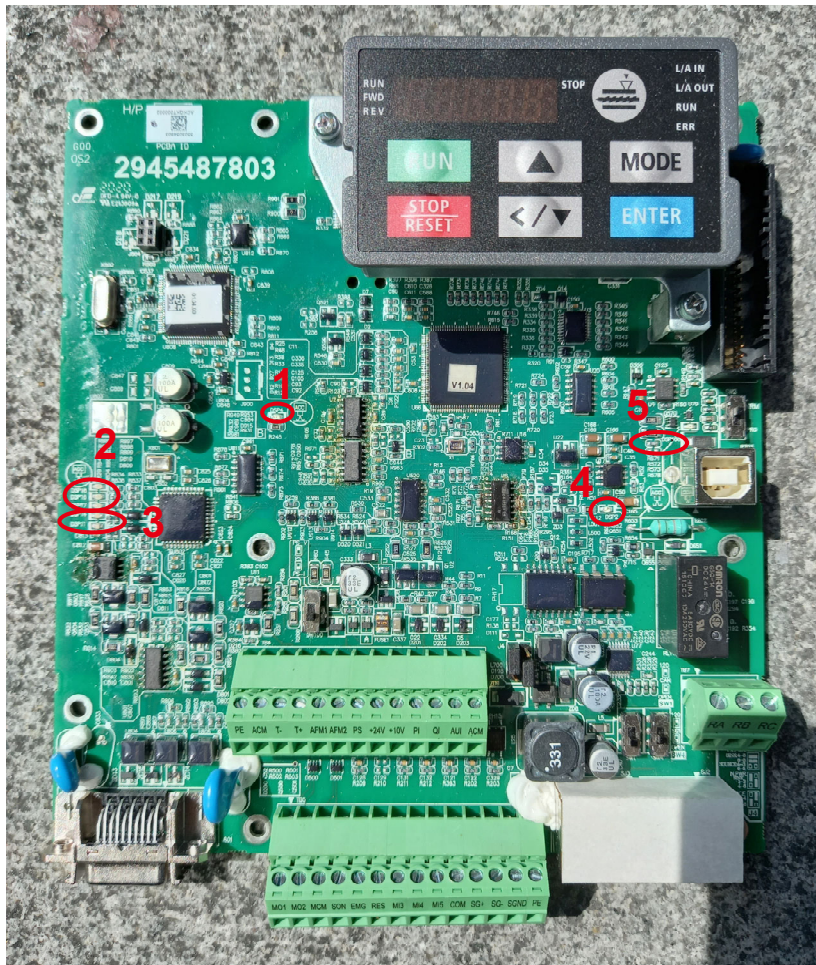

5-1-1 Indicator Display







1: Power Indicator, 2: Encoder Feedback Indicator, 3: Encoder Feedback Warning Indicator, 4: Brake Indicator







Here are two images of KPVJ-LE02 displaying unusual signals. On the left, it shows the number of the unusual signals. On the right, it shows the name of the unusual signal. The KPVJ-LE02 switches automatically back and forth between these two ways of displaying the unusual signal.



-  <E> = Error, press the RESET key to clear the error.
-  <F> = Fault, power off the hybrid servo controller, wait for 3 minutes before you repower on the servo controller
-  <A> = Alarm.













5-1-2 Error Messages Displayed on Digital Keypad KPVJ-LE02









No.	Display Code	Fault Description	Troubleshooting	Fault codes defined by Delta (2021H Low Byte)	CANopen Fault Register (1001H bit 0~7)	DS402 Fault Codes (603FH)
E1		Over current occurs in acceleration; output current exceeds by three times the rated current of the controller. (ocA)	<p>1. Check if the insulation of the wire from U-V-W to the hybrid servo controller is bad.</p> <p>2. Check if the hybrid servo controller is stalled.</p> <p>3. Such errors occur when the red light of PG card flashes. The causes of these errors could be loose contact/ disconnection between encoder, servo controller and motor.</p> <p>4. When such errors occur at the beginning, during or at the end of pressure/ flow command</p> <ul style="list-style-type: none"> ● Adjust also the ramp up/down rate of pressure/flow command (Pr00-29 to Pr00-32) or ● Adjust the pressure/ flow reference time (Pr00-46~ Pr00-49) or ● Adjust the slope from the hybrid servo controller. <p>5. When such errors occur while pressure/ flow command is constant, adjust PI value (Pr00-20 ~ Pr00-25)</p> <p>6. Make sure if there is any disturbance/ noise, set Pr00-04: #11 (Pressure feedback), #12(Pressure command), 25 (flow rate command). Then observe if the values fluctuate.</p> <p>7. Replace the hybrid servo controller with a larger output capacity model.</p>	0001H	1	2213H
E2		Over current occurs in deceleration; output current exceeds by three times the rated current of the controller. (ocD)		0002H	1	2213H
E3		Over current occurs during constant speed. Output current exceeds by three times the rated current of the controller. (ocN)		0003H	1	2214H
E4		Ground fault: Ground wire protection applies when one of the output terminal is grounded and the ground current is higher than its rated value by over 80%. Note that this protection is only for hybrid servo controller and not for human. (GFF)	<p>1. Check the wire of hybrid servo motor is shorted or grounded.</p> <p>2. Check if IGBT power module is damaged</p> <p>3. Check if the output side wire has bad insulation.</p>	0004H	1	2240H











No.	Display Code	Fault Description	Troubleshooting	Fault codes defined by Delta (2021H Low Byte)	CANopen Fault Register (1001H bit 0~7)	DS402 Fault Codes (603FH)
E5		IGBT short circuit between upper and lower bridge. (occ)	Short-circuit is detected between the upper and lower bridge of the IGBT module. Check the motor wiring. Cycle the power, if occ still exists, return to the factory for repair.	0005H	2	2250H
E6		Over-current or hardware failure in current detection at Stop. (ocs)	Send back to manufacturer for repair.	0006H	1	2214H
E7		DC BUS over-voltage during acceleration. (ovA)	230V: DC 415V 460V: DC 830V	0007H	2	3210H
E8		DC BUS over-voltage during deceleration.(ov d)	1. Check if the input voltage is within the range of voltage rating of Hybrid Servo Controller and monitor for any occurrence of surge voltage.	0008H	2	3210H
E9		DC BUS over-voltage at constant speed. (ovn)	2. The issue can be resolved by adjusting the software brake action level in Pr.02-00. 3. When such error occurred at the beginning, during or at the end of the pressure/ flow command, adjust Pr00-29 ~Pr0032 <Ramp up/down rate of pressure/ flow command> or Pr00-46 ~Pr00-49 <Pressure/ flow reference S1/S2 time>	0009H	2	3210H
E10		Over voltage occurs at stop and hardware failure. (ovS)	Check if the input voltage is within the range of voltage rating of hybrid servo controller and monitor for any occurrence of surge voltage.	000AH	2	3210H
E11		DC bus voltage is lower than the setting at Pr02-07 during acceleration. (LvA)	1. Check if the voltage of input power is normal. 2. Check if there is any sudden heavy load. 3. Adjust the low voltage level in Pr02-07.	000BH	2	3220H

No.	Display Code	Fault Description	Troubleshooting	Fault codes defined by Delta (2021H Low Byte)	CANopen Fault Register (1001H bit 0~7)	DS402 Fault Codes (603FH)
E12		DC bus voltage is lower than the setting in Pr02-07 during deceleration. (Lvd)	4. Lvn often occurs when the servo controller has a power failure while the operating signals are still being sent.	000CH	2	3220H
E13		DC bus voltage is lower than the setting at Pr02-07 when running at constant speed (Lvn)		000DH	2	3220H
E14		DC bus voltage is lower than the setting at Pr02-07 at stop (LvS)		000EH	2	3220H
E15		Phase loss protection (orP)	Check if only single phase power is sent or phase los occurs for three phase models	000FH	2	3130H
E16		IGBT's temperature exceeds the protection level (oH1)	<ol style="list-style-type: none"> 1. Check if ambient temperature is too high. 2. Check if there is any foreign object on the heat sink and if the fan is running. 3. Check if there is sufficient space for air circulation for Hybrid Servo Controller 	0010H	3	4310H
E17		Capacitors' temperature exceeds the protection level) (oH2)	<ol style="list-style-type: none"> 1. Check if ambient temperature is too high. 2. Check if there is any foreign object on the heat sink and if the fan is running. 3. Check if there is sufficient space for air circulation for hybrid servo controller 	0012H	3	FF00H
E18		Hardware failure (tH1o)	Send back to manufacturer for repair.	0012H	8	FF00H
E19		Hardware failure (tH2o)	Send back to manufacturer for repair.	0012H	8	FF01H
E20		IGBT overheated and cooling fan failure. (oHF)	Check the fan kit to see if it is blocked. Return to factory for repair.	0013H	4	FF02H







No.	Display Code	Fault Description	Troubleshooting	Fault codes defined by Delta (2021H Low Byte)	CANopen Fault Register (1001H bit 0~7)	DS402 Fault Codes (603FH)
E21		The hybrid motor controller detects excessive output current (oL)	<ol style="list-style-type: none"> 1. Check if the hybrid servo motor is stalled. 2. Replace the hybrid servo controller with a larger output capacity model. 3. Set Pr00-04=29, observe if the value returns to zero after every molding cycle. If the number accumulates to 100, OL occurs 4. The causes of this error could be loose contact/ disconnection between encoder, servo controller and the motor. This error also occurs when a motor or an oil pump is stalled which make unusual rotating speed and over current. 	0015H	1	2310H
E22		Servo motor overload (EoL1)	<ol style="list-style-type: none"> 1. Set Pr00-04=30 (v2.06 and above), observe if the value returns to zero after every molding cycle. If the number accumulates to 100, EoL occurs. Change the molding conditions. 2. Replace with the hybrid servo controller with a larger output capacity model. 3. If the pressure –flow is too high during the blending, such error occurs easily. To clear this error, decrease the pressure command and the flow command. 	0016H	1	2310H
E24		(02-09 PTC level) Overheating inside the servo controller detected by hybrid servo controller, exceeding the protection level (Pr02-09 PTC level) (oH3).	<ol style="list-style-type: none"> 1. Check if the servo controller is blocked. 2. Check if the ambient temperature is too high. 3. Increase the capacity of the servo controller. 	0018H	3	FF20H





No.	Display Code	Fault Description	Troubleshooting	Fault codes defined by Delta (2021H Low Byte)	CANopen Fault Register (1001H bit 0~7)	DS402 Fault Codes (603FH)
E30		Error on memory write-in (cF1)	Press RESET key to return all parameters to factory default values If the above does not work, send back to manufacturer for repair.	001EH	32	5530H
E31		Error on memory readout (cF2)		001FH	5	5530H
F32		Detection of abnormal output of three-phase total current (cd0)	Turn off the power and restart. If the same problem persists, send back to manufacturer for repair	0020H	2	FF03H
F33		Detection of abnormal current in phase U (cd1)		0021H	1	FF04H
F34		Detection of abnormal current in phase V (cd2)		0022H	1	FF05H
F35		Detection of abnormal current in phase W (cd3)		0023H	1	FF06H
F36		Clamp current detection error (Hd0)	Turn off the power and restart. If the same problem persists, send back to manufacturer for repair.	0024H	5	FF07H
F37		Over-current detection error (Hd1)		0025H	5	FF08H
F38		Over-voltage detection error (Hd2)		0026H	5	FF08H
F39		Ground current detection error (Hd3)		0027H	5	FF08H
E40		Auto tuning error (AuE)	1. Check if the wiring of the motor is correct. 2. Check if the motor's parameter settings are correct.	0028H	1	FF21H
E42		PG feedback error (PGF1)	The actual rotating speed doesn't follow speed command and the elapsed time longer than one second. In this case, check if Pr01-30 is not equal to zero and check PG feedback wiring	002AH	7	7301H
E43		PG feedback loss (PGF2)	Check the PG feedback wiring. It could be an open circuit.	002BH	7	7301H





No.	Display Code	Fault Description	Troubleshooting	Fault codes defined by Delta (2021H Low Byte)	CANopen Fault Register (1001H bit 0~7)	DS402 Fault Codes (603FH)
E44		Stalled PG feedback (the actual rotating speed is 115% faster than the maximum speed and the elapsed time longer than one second) (PGF3)	<ol style="list-style-type: none"> 1. Check the PG feedback wiring. 2. Check if PI gain and the settings for acceleration/ deceleration are suitable. 3. Check if there's an output phase loss. 4. The causes of these errors could be loose contact/ disconnection between encoder, hybrid servo motor controller and motor. (OC might also occur in different conditions.). 	002CH	7	7301H
E45		PG slip error (PGF4)	<ol style="list-style-type: none"> 5. Check if the connection between oil pump and motor is stuck. 6. Send back to manufacturer for repair. 	002DH	7	7301H
E49		When external terminals EF are closed, Hybrid servo controller stops its output (EF)	Troubleshoot and press "RESET"	0031H	5	9000H
E50		When external EMG terminal is not connected to the heating switch of hybrid servo motor or the motor is overheated (130 °C), hybrid servo controller stops its input (EF1)	Troubleshoot and press "RESET"	0032H	5	9000H
F52		Password is locked after three attempts (Pcod)	Shut down the servo controller, wait for certain time. Make sure that the power indicator is off. (≤ 22kW: wait for 5 min after shut down; ≥ 30kW: wait for 10 min after shut down). Then restart the servo controller and enter the right password	0034H	5	FF26H
F53		CPU fault (ccod)	Send back to manufacturer for repair.	0035H	4	7500H
E54		Illegal command (cE1)	Verify if the communication command is correct (Communication code must be 03, 06, 10)	0036H	4	7500H
E55		Illegal data address (cE2)	Verify if the communication data length is correct.	0037H	4	7500H

No.	Display Code	Fault Description	Troubleshooting	Fault codes defined by Delta (2021H Low Byte)	CANopen Fault Register (1001H bit 0~7)	DS402 Fault Codes (603FH)
E56		Illegal data value (cE3)	Verify if the data value is bigger than the maximum or smaller than the minimum value.	0038H	4	7500H
E57		Data is written to read-only address (cE4)	Verify if the communication address is correct.	0039H	4	7500H
E58		Modbus transmission time-out (cE10)	Verify the wiring and grounding of the communication circuit. Press RESET button on the keypad to clear this error code. If cE10 persists, send back to manufacturer for repair.	003AH	4	7500H
E60		Brake transistor error (bF)	Press RESET button on the keypad to clear this error code. If bF persists, send back to manufacturer for repair.	003BH	5	7110H
E65		Hardware error of PG card or magnetic pole tuning fault (PGF5)	Verify the setting of Pr.01-07 Motor Parameter Auto Tuning. If this fault is persistent, send it back to the manufacturer for repairing.	0041H	5	FF29H
E66		Overpressure (ovP)	<ol style="list-style-type: none"> 1. Check if the pressure sensor is working properly and if its specification is correct. 2. Adjust pressure PI control Pr.00-20~00-37 3. Check if the wiring of pressure sensor is correct. 4. Check the position of SW100 dip switch (current type or open collector) on the control board if correct. 	0042H	5	FF29H
E67		Pressure feedback fault (PfbF)	<ol style="list-style-type: none"> 1. Check if the wiring of pressure sensor is correct. It could be open-circuit. 2. Check if the pressure sensor signal is below 1V. 	0043H	5	FF29H
E68		Oil pump runs reversely (Prev)	<ol style="list-style-type: none"> 1. Check if there's any zero shift at the pressure sensor. 2. Check if the wiring of pressure sensor is correct. 	0044H	5	FF29H
E69		Oil shortage (noil)	<ol style="list-style-type: none"> 1. Check the amount of oil in the oil tank. 2. Check if any leakage at hydraulic circuit. 3. If there's a suction filter installed at the oil inlet, check if that suction filter is blocked up. 	0045H	5	FF29H
E70		Business hours end. (tUP)	Send back to manufacturer for repair.	0046H	32	FF29H

No.	Display Code	Fault Description	Troubleshooting	Fault codes defined by Delta (2021H Low Byte)	CANopen Fault Register (1001H bit 0~7)	DS402 Fault Codes (603FH)
E71		Over current at braking chopper (ocbs)	<ol style="list-style-type: none"> 1. Check if the braking chopper is short-circuit? 2. Is the resistance value too small? 3. Send back to manufacturer for repair 	0047H	1	FF29H
F72		Braking resistor is open-circuit (bro)	Check if the braking resistor is open-circuit or properly wired?	0048H	32	FF29H
F73		Braking resistor's resistance value is too small. (brF)	Check if the resistance value big enough?	0049H	32	FF29H
E74		Braking chopper overheated (oH4)	<ol style="list-style-type: none"> 1. Check if there are too many times of deceleration and pressure releasing during formation period? 2. Modify formation period 	004AH	3	FF29H
E75		Error occurred on braking chopper's thermo-protection line (tH4o)	Send back to manufacturer for repair.	004BH	3	FF29H
E78		.The ground short is detected before running the servo controller, because all the upper arms or all the lower arms are turned on.(b.GFF)	Only after this fault occurs for 5 seconds, you can reset the servo controller. If this fault is persistent, send it back to the manufacturer for repairing.	004Eh	2	0x2240H
E79		The U-phase short is detected before running the servo controller because U-phase and V-phase are turned on.(A.oc)	Only after this fault occurs for 5 seconds, you can reset the servo controller. If this fault is persistent, send it back to the manufacturer for repairing.	004Fh	2	0x2213H

No.	Display Code	Fault Description	Troubleshooting	Fault codes defined by Delta (2021H Low Byte)	CANopen Fault Register (1001H bit 0~7)	DS402 Fault Codes (603FH)
E80		The V-phase short is detected before running the servo controller because V-pase and W-phase are turned on.(b.oc)	Only after this fault occurs for 5 seconds, you can reset the servo controller. If this fault is persistent, send it back to the manufacturer for repairing.	0050h	2	0x2213H
E81		The W-phase short is detected before running the servo controller because U-pase and W-phase are turned on.(c.oc)	Only after this fault occurs for 5 seconds, you can reset the servo controller. If this fault is persistent, send it back to the manufacturer for repairing.	0051h	2	0x2213H
E82		Output Phase Loss on Phase U (oPL1)	1 Check if the wiring of motor to see if any loose or broken wires.	0052H	2	FF29H
E83		Output Phase Loss on Phase V (oPL2)	2. Check if the resistance of each phase is the same. 3. Use an ampere-meter to measure if the	0053H	2	FF29H
E84		Output Phase Loss on Phase W (oPL3)	three-phase current is in balance. If this error code still pops up when it is in balance, send back to manufacturer for repair. 4. Choose a motor and a servo controller which are compatible with each other.	0054H	2	FF29H
E87		Servo controller overloading while running at low frequency (oL3)	1. Reduce the ambient temperature of the operating controller. 2. Replace the controller with a larger power model. 3. Reset controller parameters or decrease carrier frequency. Send back to the manufacturer for repair if none of the above works.	0057H	2	2310H
E93		The current at U-phase is too small. (The IGBT at U-phase is open circuit or an error occurs on the current sensor.) (AUE.A)	1. Verify if the servo controller and the motor are properly connected 2. The magnetic contactor installed on the output side (U/V/W) of the servo controller is at open-circuit. Make sure that it has to be at close-circuit.	005Dh	2	3210H

No.	Display Code	Fault Description	Troubleshooting	Fault codes defined by Delta (2021H Low Byte)	CANopen Fault Register (1001H bit 0~7)	DS402 Fault Codes (603FH)
E94		The current at V-phase is too small. (The IGBT at V-phase is open circuit or an error occurs on the current sensor.) (AUE.b)	<ol style="list-style-type: none"> 1. Verify if the servo controller and the motor are properly connected 2. The magnetic contactor installed on the output side (U/V/W) of the servo controller is at open-circuit. Make sure that it has to be at close-circuit. 	005Eh	2	3210H
E95		The current at W-phase is too small. (The IGBT at W-phase is open circuit or an error occurs on the current sensor.) (AUE.c)	<ol style="list-style-type: none"> 1. Verify if the servo controller and the motor are properly connected 2. The magnetic contactor installed on the output side (U/V/W) of the servo controller is at open-circuit. Make sure that it has to be at close-circuit. 	005Fh	2	3210H
E96		Error occurred on the encoder (cable connection error) (AUE.P)	<ol style="list-style-type: none"> 1. Verify if the encoder is properly connected to the servo controller and if the parameters are correctly set. 2. Reboot the hybrid servo controller. 3. If this fault is persistent, sent it back to the manufacturer for repairing. 	0060h	128	7301H
E101		Software error 1 occurred on CANopen (CGdE) (CANopen guarding error)	<ol style="list-style-type: none"> 1. Increase guarding time (Index 100C). 2. Check the communication wiring and grounding. 90 degrees wiring layout or separation from main circuit is suggested to prevent interference. 3. Make sure the communication wiring is serial. 4. Use dedicated CANopen cable and install terminating resistor. 5. Check the status of communication cable or change new cable. 	0065H	4	8130H
E102		Software error 2 occurred on CANopen (CHbE) (CANopen heartbeat error.)	<ol style="list-style-type: none"> 1. Increase Heart beat time (Index 1016). 2. Check the communication wiring and grounding. 90 degrees wiring layout or separation from main circuit is suggested to prevent interference. 3. Make sure the communication wiring is serial. 4. Use dedicated CANopen cable and install terminating resistor. 5. Check the status of communication cable or change new cable. 	0066H	4	8130H

No.	Display Code	Fault Description	Troubleshooting	Fault codes defined by Delta (2021H Low Byte)	CANopen Fault Register (1001H bit 0~7)	DS402 Fault Codes (603FH)
E104		Hardware error occurred on CANopen (CbFE) (CANopen bus off error)	<ol style="list-style-type: none"> 1. Re-install CANopen card. 2. Check the communication wiring and grounding. 90 degrees wiring layout or separation from main circuit is suggested to prevent interference. 3. Make sure the communication wiring is serial. 4. Use dedicated CANopen cable and install terminating resistor. 5. Check the status of communication cable or change new cable. 	0068H	4	8140H
E105		Index setting error occurred on CANopen (CIdE) (CANopen index error)	<p>Disable CANopen (Pr.04-17=0) Reset CANopen Index (Pr.04-17)</p>	0069H	4	8100H
E106		Slave # setting error occurred on CANopen (CADE)	<p>Disable CANopen (Pr.04-17=0) Reset CANopen Index (Pr.04-17)</p>	006AH	4	8100H
E107		CANopen's Index is Out of Range (CFrE) (CANopen memory error)	<p>Disable CANopen(Pr.04-17=0) Reset CANopen Index (Pr.04-17)</p>	006BH	4	8100H

Reset Alarm:

Once the issue that tripped the system and triggers the alarm is eliminated, one can resume the system to normal status by pressing the RESET key on the digital keypad (as shown in the image below) to set the external terminal to "Anomaly reset command" and sending the command by turning on the terminal or via communication. Before any anomaly alarm is resolved, make sure the operation signal is at open circuit status (OFF) to avoid immediate machine running upon anomaly reset that may cause mechanical damage or personnel casualty.

Stop/ Reset key:
Press this button to stop running and reset abnormality

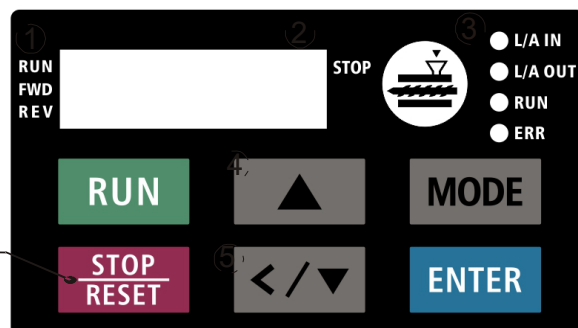

5-1-3 Warning Codes

No.	Display	Fault codes defined by Delta (2021H High Byte)	Descriptions
A1	CE 1	0001H	Modbus function code error (Illegal function code) (CE1) Corrective Actions <ul style="list-style-type: none"> ■ Check if the function code is correct. (Function code must be 03, 06, 10, 63)
A2	CE 2	0002H	Modbus data address is error (Illegal data address (00 H to 254 H) (CE2) Corrective Actions <ul style="list-style-type: none"> ■ Check if the communication address is correct.
A3	CE 3	0003H	Modbus data error (Illegal data value) (CE3) Corrective Actions <ul style="list-style-type: none"> ■ Check if the data value exceeds maximum / minimum value.
A4	CE 4	0004H	Modbus communication error (Data is written to read-only address) (CE4) Corrective Actions <ul style="list-style-type: none"> ■ Check if the communication address is correct.
A5	CE 10	0005H	Modbus transmission time-out (CE10)
A6	CP 10	0006H	Keypad transmission time-out (CP10)
A7	SE 1	0007H	Keypad COPY error 1 (SE1) Keypad simulation error, including communication delays, communication error (keypad receives error FF86) and parameter value error.
A8	SE 2	0008H	Keypad COPY error 2 (SE2) Keypad simulation done, parameter writes error.
A9	oH 1	0009H	IGBT is over-heated than protection level: 95°C (oH1) Corrective Actions <ul style="list-style-type: none"> ■ Ensure that the ambient temperature falls within the specified temperature range. ■ Make sure that the ventilation holes are not obstructed. ■ Remove any foreign objects from the heat sink and check for possible dirt in heat sink. ■ Provide enough spacing for adequate ventilation.

No.	Display	Fault codes defined by Delta (2021H High Byte)	Descriptions
A10	oH2	000AH	<p>Servo controller is over-heated than protection level: 95°C. This warning code is ONLY for frame E, NOT for other frames.(oH2)</p> <p>Corrective Actions</p> <ul style="list-style-type: none"> ■ Ensure that the ambient temperature falls within the specified temperature range. ■ Make sure that the ventilation holes are not obstructed. ■ Remove any foreign objects from the heat sink and check for possible dirt in heat sink. ■ Provide enough spacing for adequate ventilation.
A11	PI d	000BH	PID feedback loss (PID)
A14	AUE	000EH	<p>Motor parameters auto-tuning error (AuE)</p> <p>Corrective Actions</p> <ul style="list-style-type: none"> ■ Check if motor wiring is correct. ■ Check if motor capacity and parameters are correct.
A15	PGFb	000FH	<p>PG feedback error (PGFb)</p> <p>Corrective Actions</p> <ul style="list-style-type: none"> ■ Check if the encoder's wiring is correct. ■ Check if PG card's red light is on because of some interferences.
A17	oSPd	0011H	Over speed warning (oSPd)
A18	dAuE	0012H	Over speed deviation warning (dAuE)
A19	PHL	0013H	Input Phase Loss (PHL)
A22	oH3	0016H	Motor over-heating (oH3)
A24	oSL	0018H	Over slip (oSL)
A25	tUn	0019H	Auto-tuning in process (tUn)
A26	FAn	001AH	<p>Cooling fan jammed (FAn)</p> <p>Corrective Actions</p> <ul style="list-style-type: none"> ■ Check if the cooling spins or not. ■ Clean the cooling fan

No.	Display	Fault codes defined by Delta (2021H High Byte)	Descriptions
A27	bP	001BH	<p>The function of this warning code is to prevent oil pump from damaging while running without sucking in any hydraulic oil. When the hybrid servo controller goes from STOP to RUN, it starts to check if the pressure is over 0.5Bar within the time set at Pr.00-60. During this checking period, the servo controller refuses pressure command and flow command sent from keypad. The keypad displays bp (building pressure).</p> <p>If the pressure is still under 0.5bar after the checking period set at Pr.00-60, there will be an oil shortage warning and the hybrid servo controller will stop running. The keypad will display noil (no oil).</p> <p>If the pressure is over 0.5bar within the checking time set at Pr00-60, the hybrid servo controller continues to run normally. There won't be a bp warning. (bP)</p> <p>※ This function is effective when Pr.00-27 <minimum pressure> is set as higher than 0.3% and the time setting at Pr.00-60 is NOT 0.</p>
A28	oPHL	001CH	Output Phase Loss (oPHL)
A36	CGdn	0024H	Software error 1 occurred on CANopen (CGdn)
A37	CHbn	0025H	Software error 2 occurred on CANopen (CHbn)
A38	CSyn	0026H	CANopen Synchronization off (CSyn)
A39	CbFn	0027H	CANopen bus off (CbFn)
A40	CIdn	0028H	CANopen index error (CIdn)
A41	CAdn	0029H	CANopen station address error (CAdn)
A42	CFrn	002AH	CANopen memory error (CFrn)
A43	CSdn	002BH	CANopen SDO transmission time-out (CSdn)
A44	CSbn	002CH	CANopen SDO received register overflow (CSbn)

No.	Display	Fault codes defined by Delta (2021H High Byte)	Descriptions
A45	Cbtn	002DH	CANopen boot up fault (CBtn)
A46	CPtn	002EH	CANopen protocol format error (CPtn)
A50	SFAn	0032H	Reminder of the maintenance of the cooling fan. (S.FAn)
A60	LrEL	003CH	Reminder of the remaining lifespan of the soft-start relay. (L.rEL)
A61	LFAn	003DH	Reminder of the remaining lifespan of the cooling fan. (L.FAn)

5-2 Dynamic fault processing and troubleshooting

E1. ocA: Over current in Acceleration

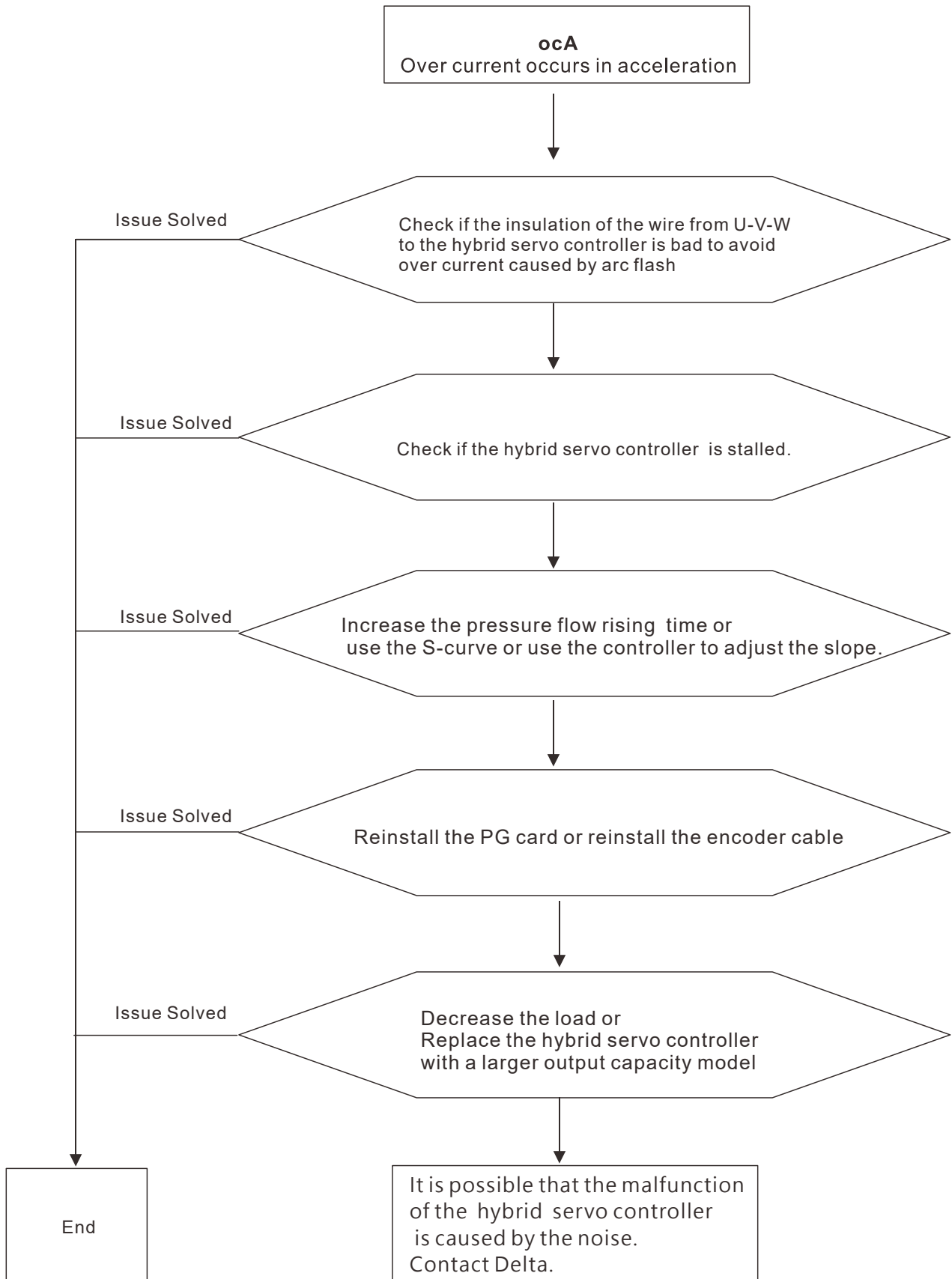

E2. ocd: Over current in Deceleration

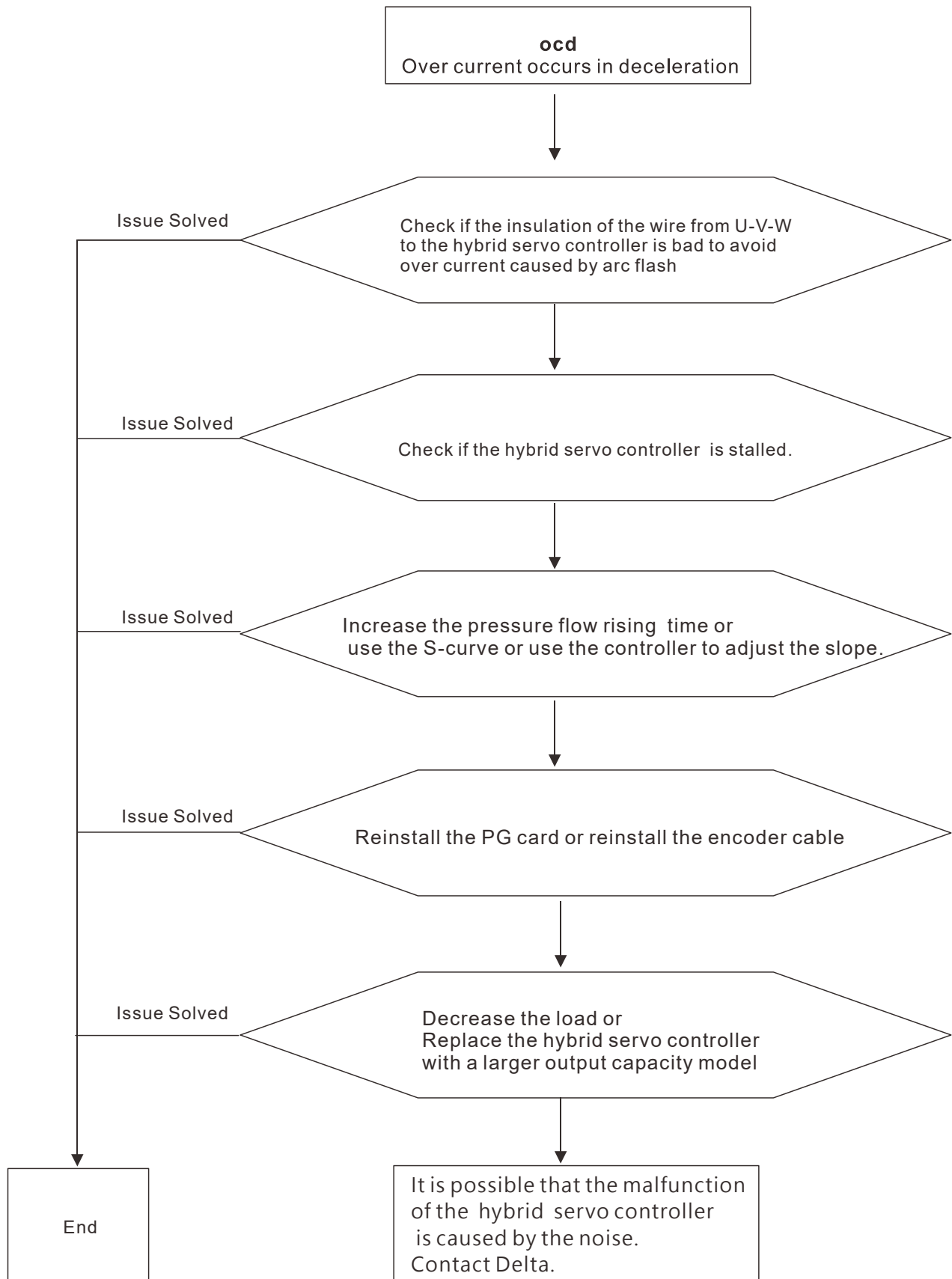

E3. ocn: Over current during Cconstant Speed.

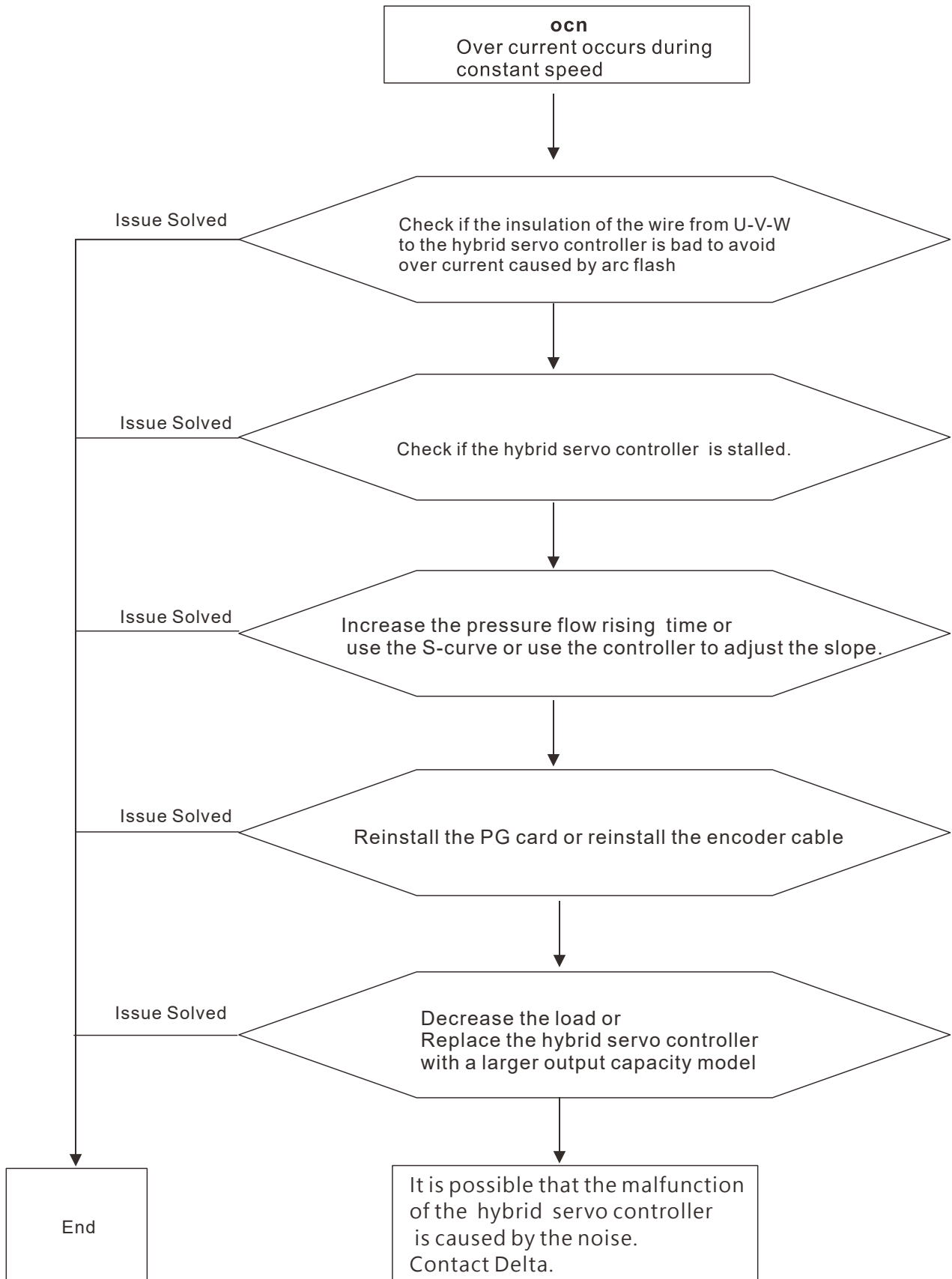

E4. GFF: Ground Fault: Ground wire protection

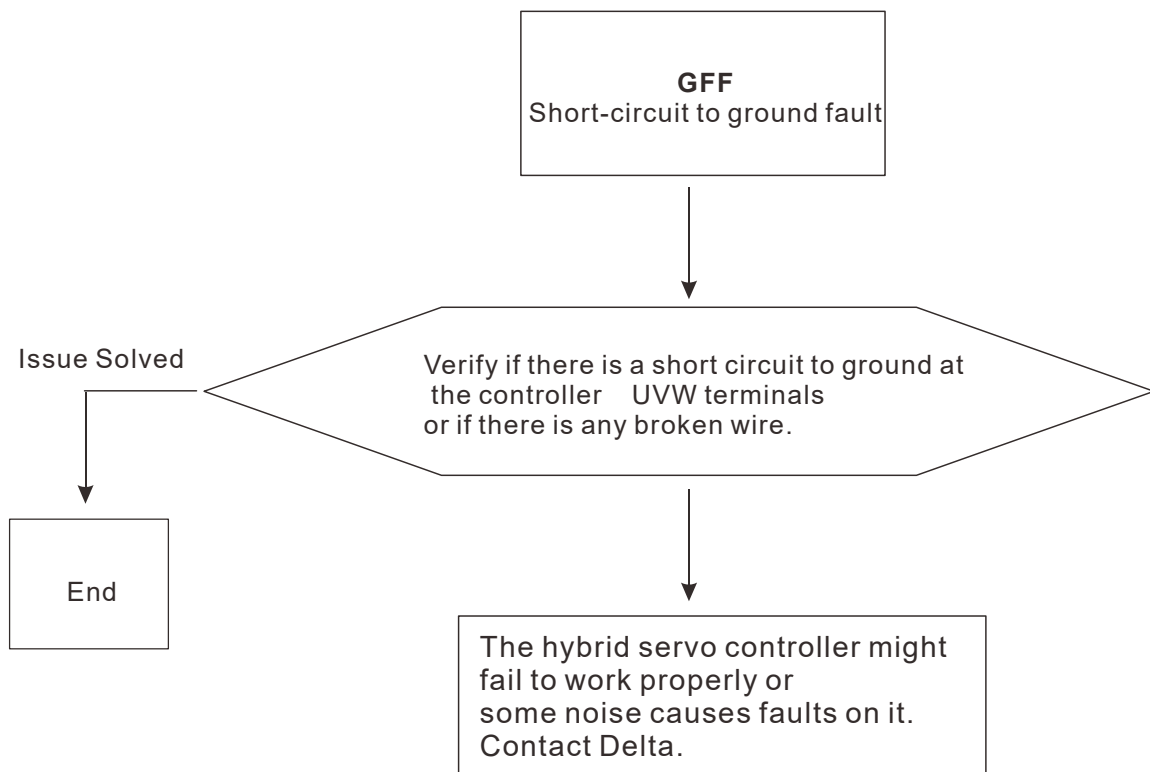

E5. occ: IGBT short circuit between upper and lower bridge

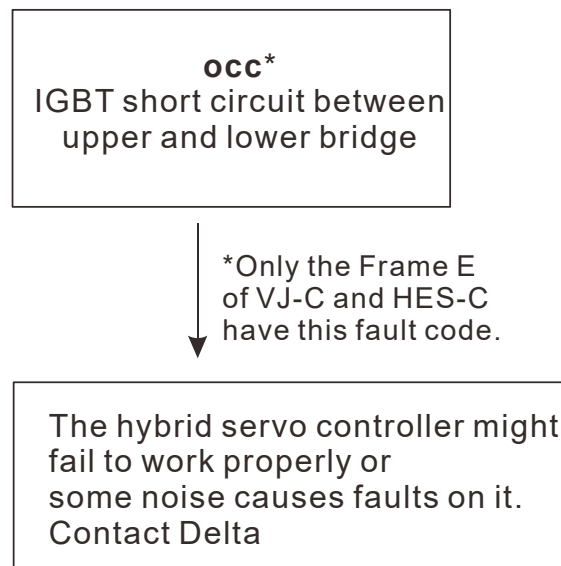

E6. ocS: Over-current or hardware failure in current detection at Stop.

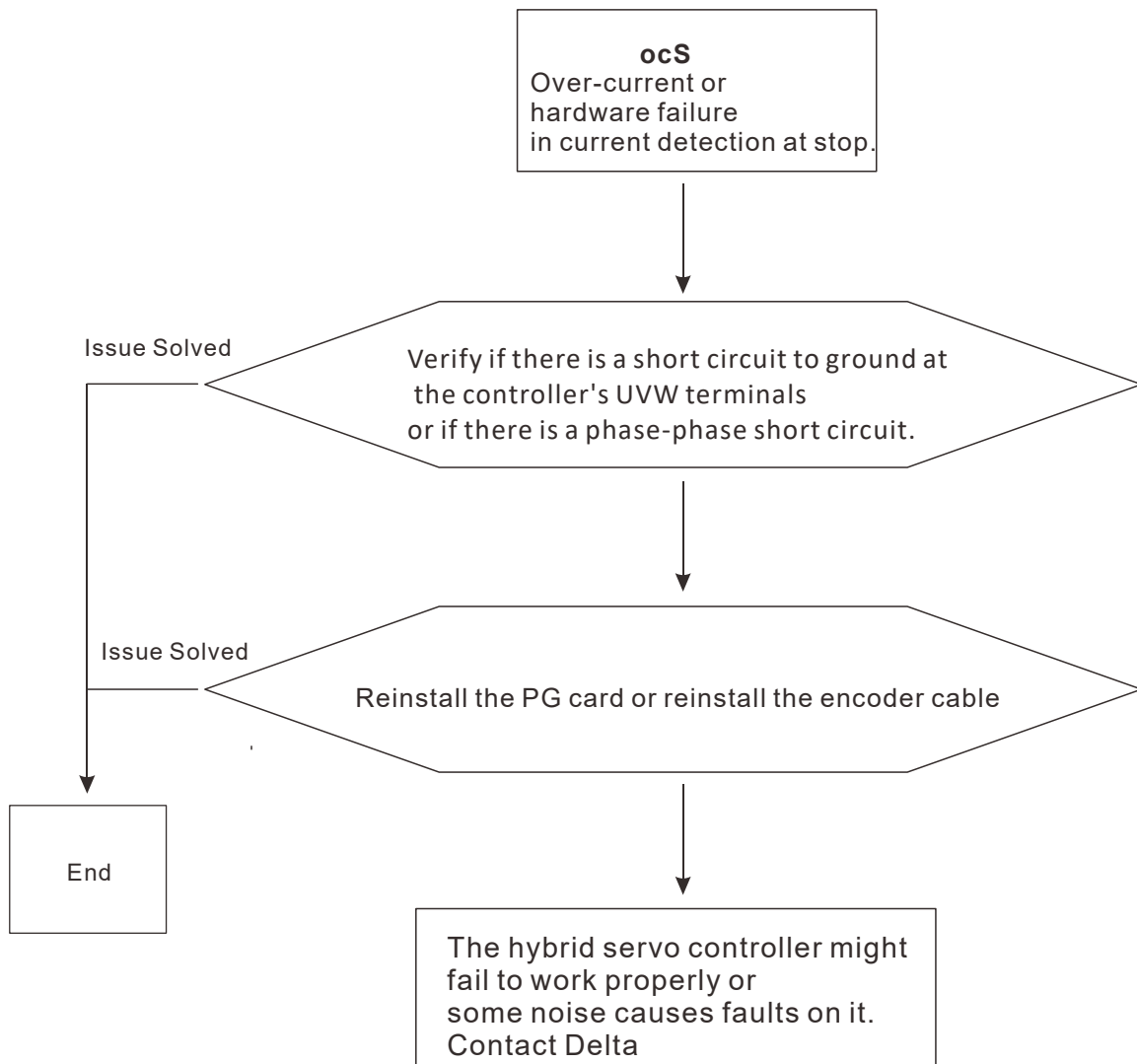

E7. ovA: DC bus over voltage during acceleration

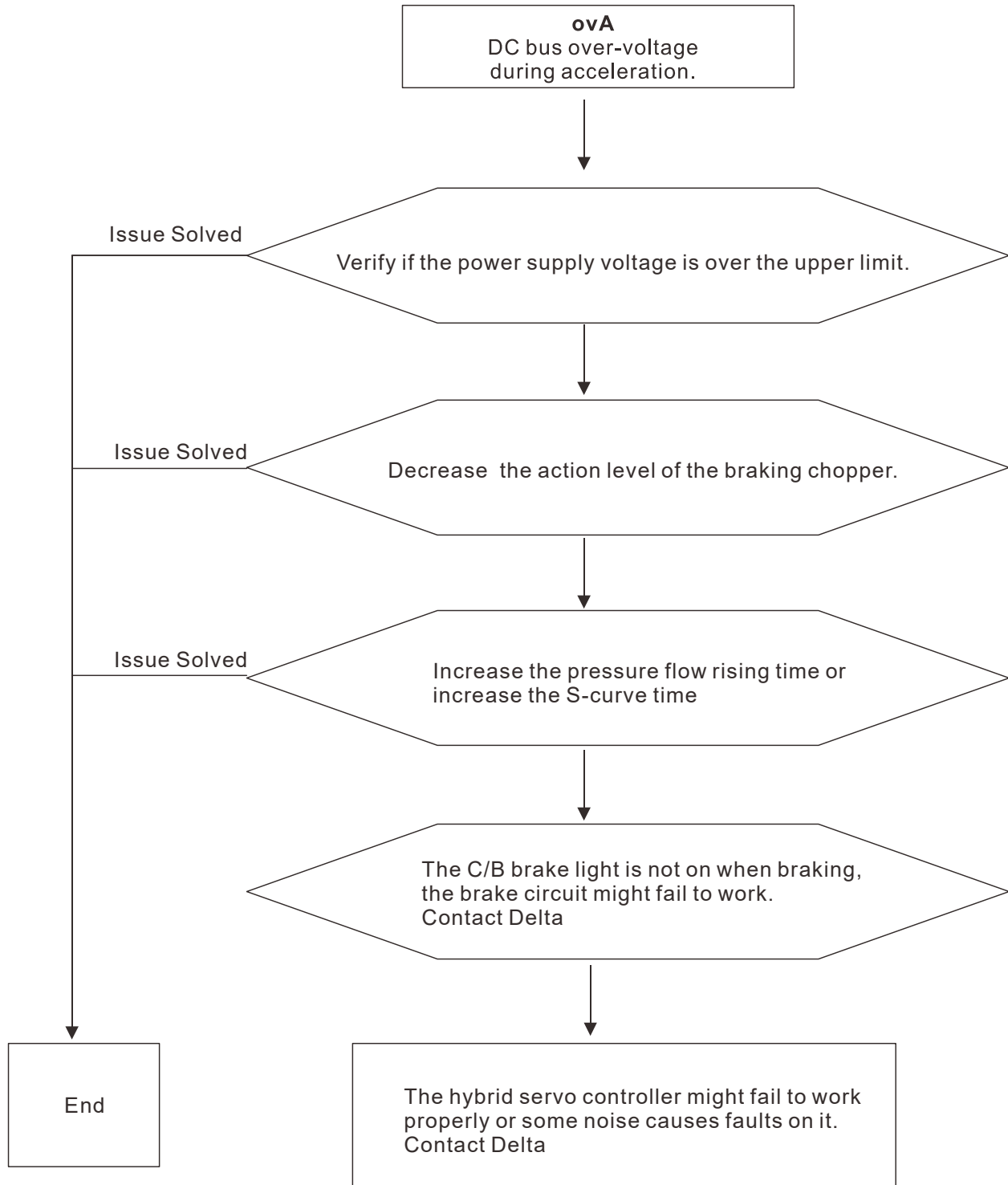

E8. ovd: DC bus over-voltage during deceleration

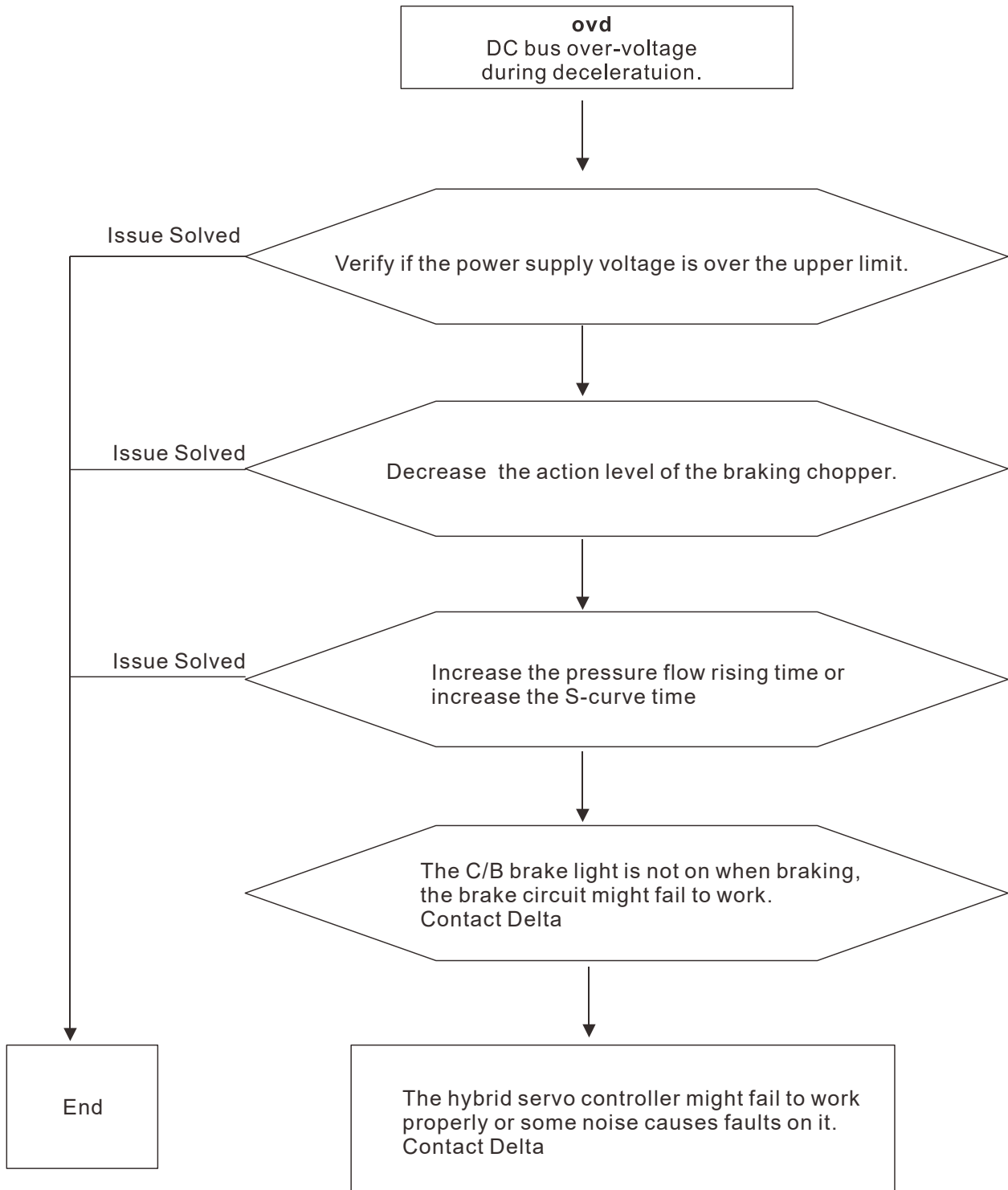

E9. ovn: DC bus over-voltage at constant speed.

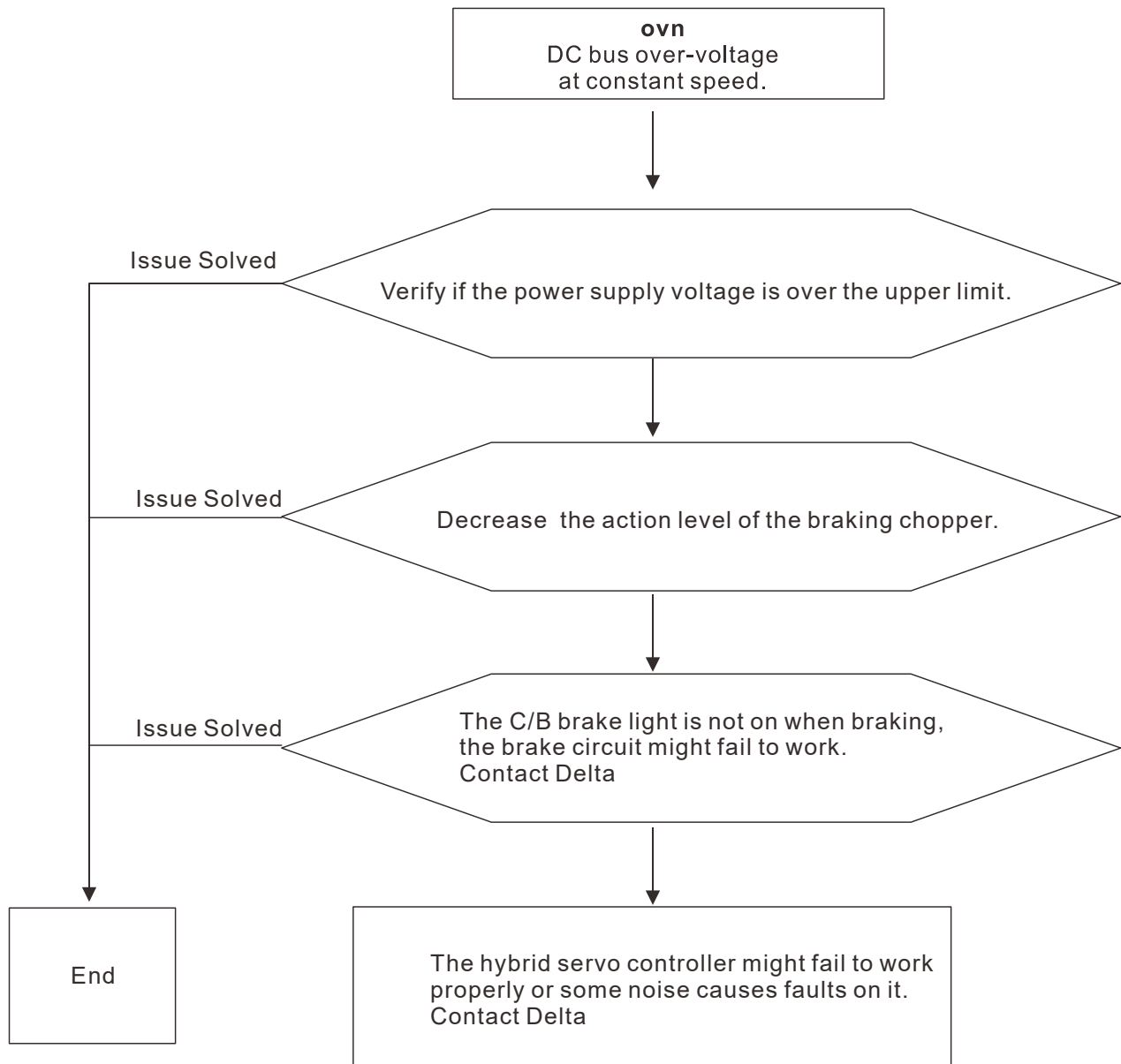

E11. LvA: DC bus voltage is lower than the setting at Pr.02-07 during acceleration.

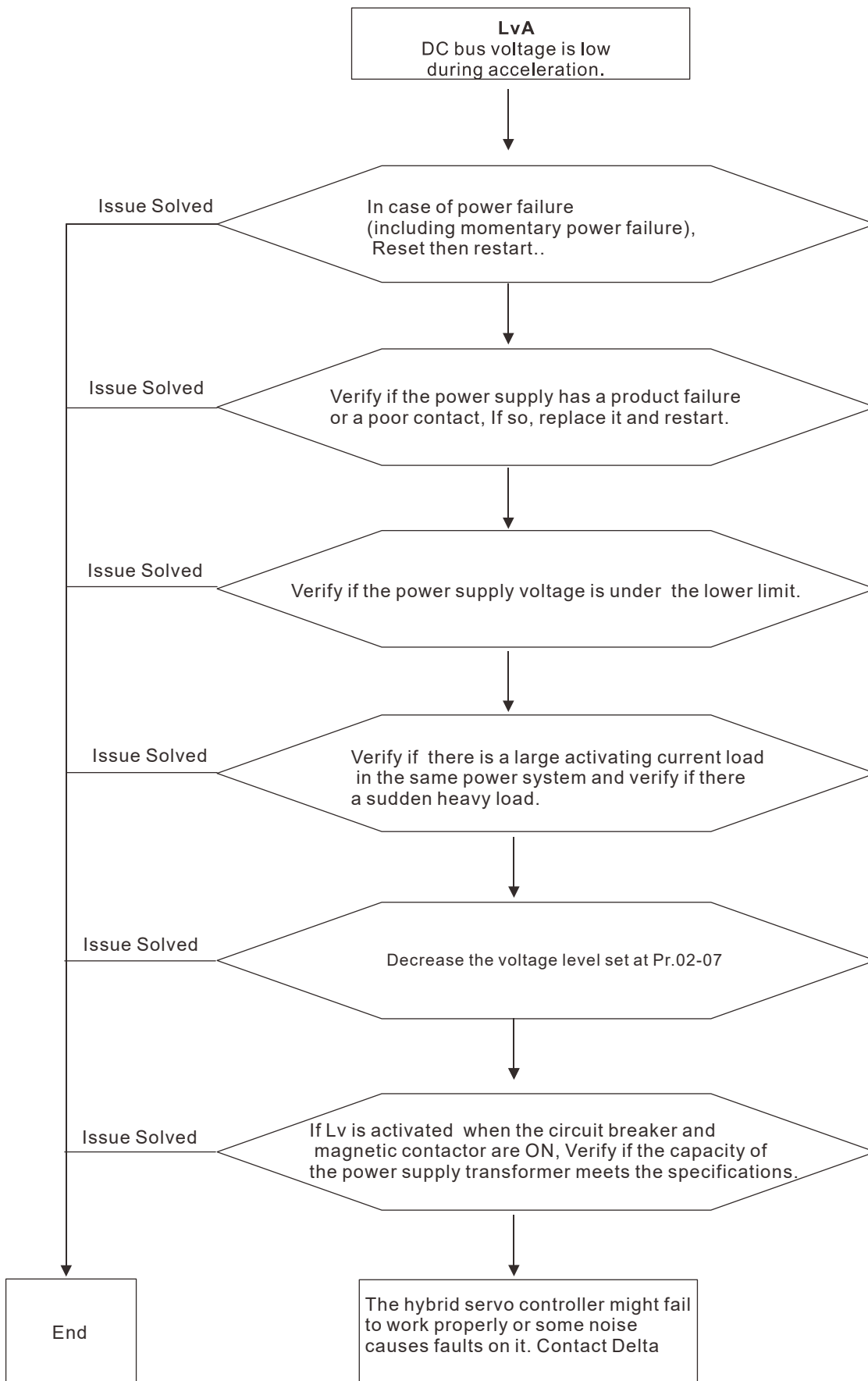

E12. Lvd: DC bus voltage is lower than the setting at Pr.02-07 during deceleration.

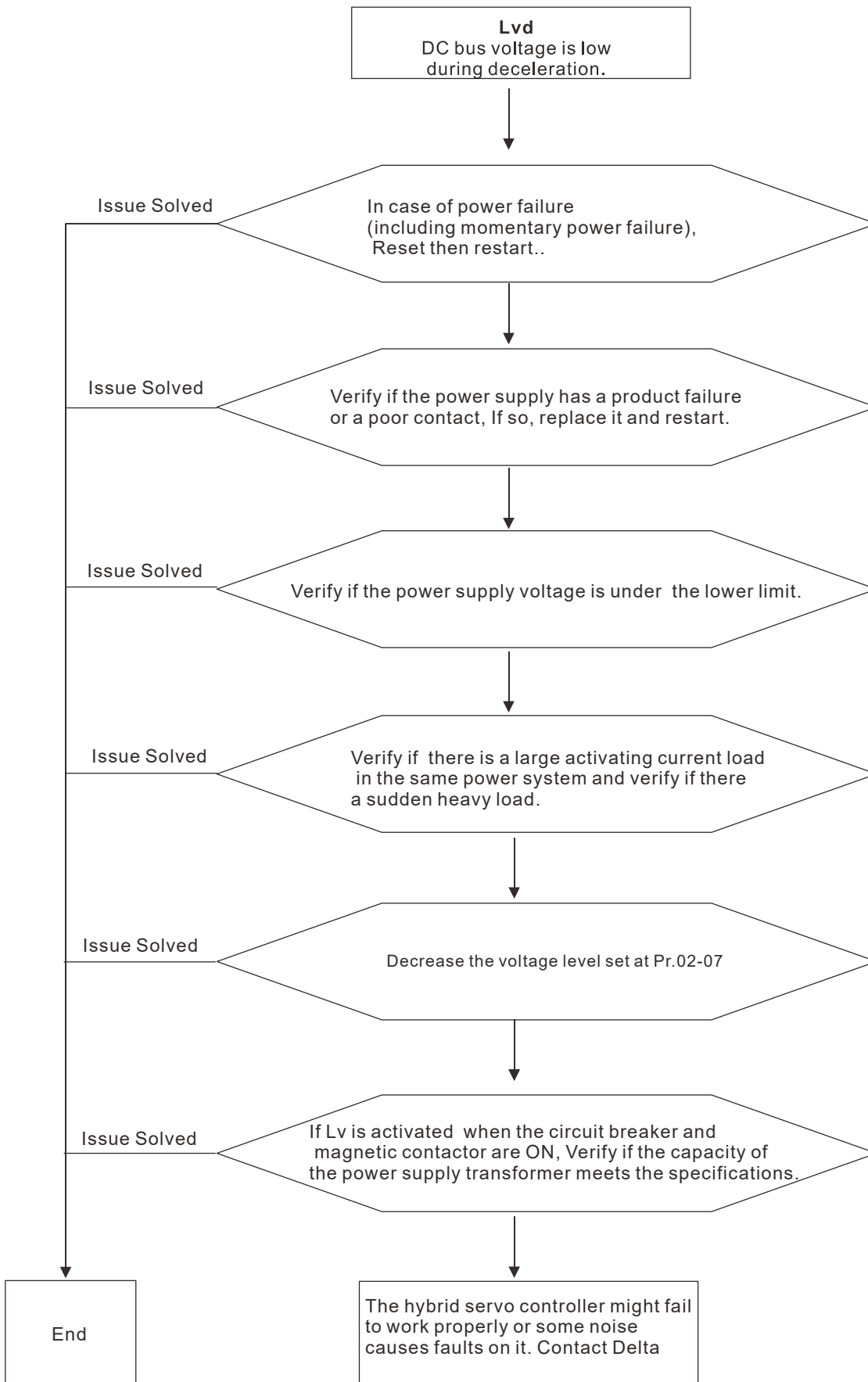

E13. Lvn: DC bus voltage is lower than the setting at Pr.02-07 when running at constant speed

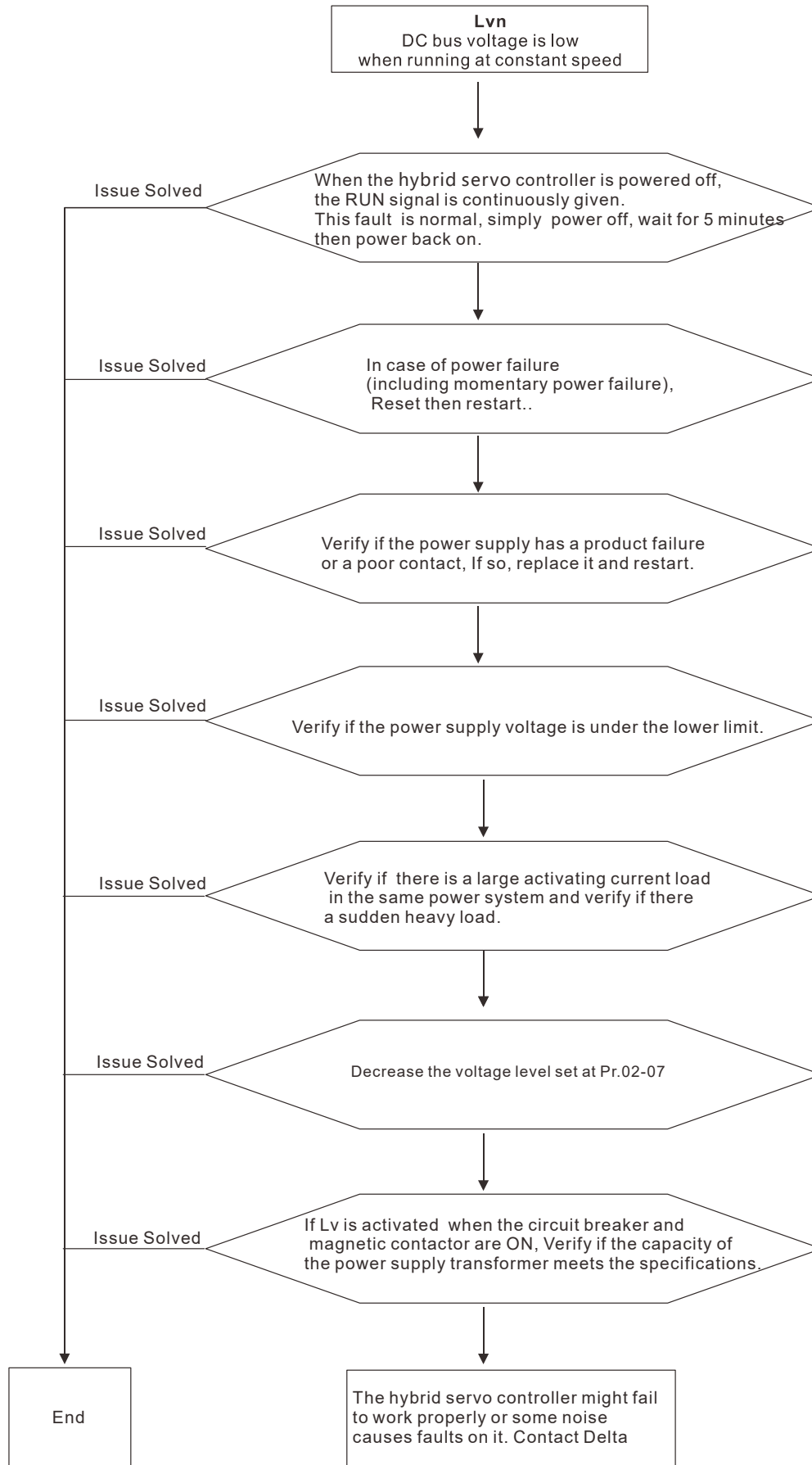

E14. LvS: DC bus voltage is lower than the setting at Pr02-07 at stop

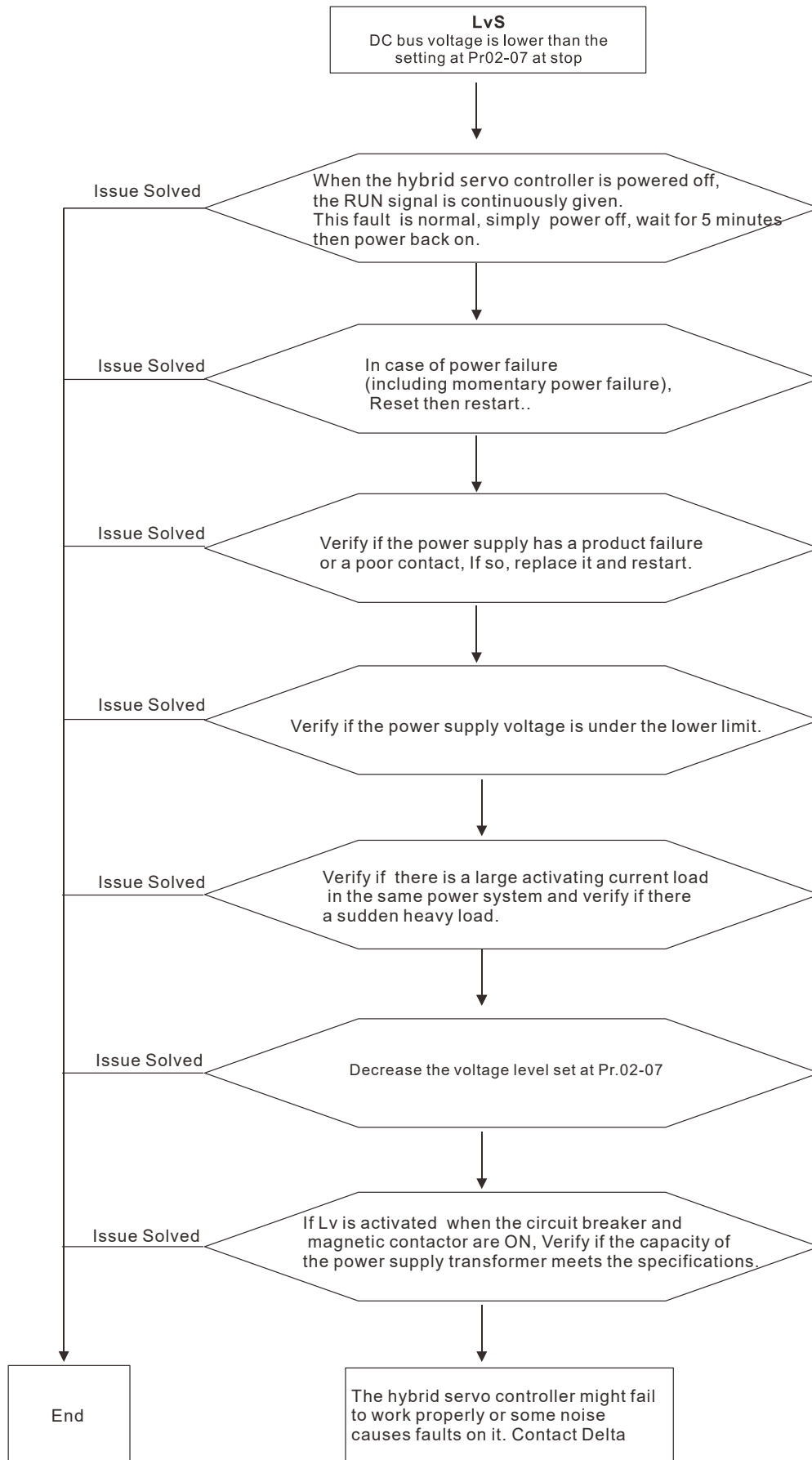

E15. orP: Phase Loss Protection

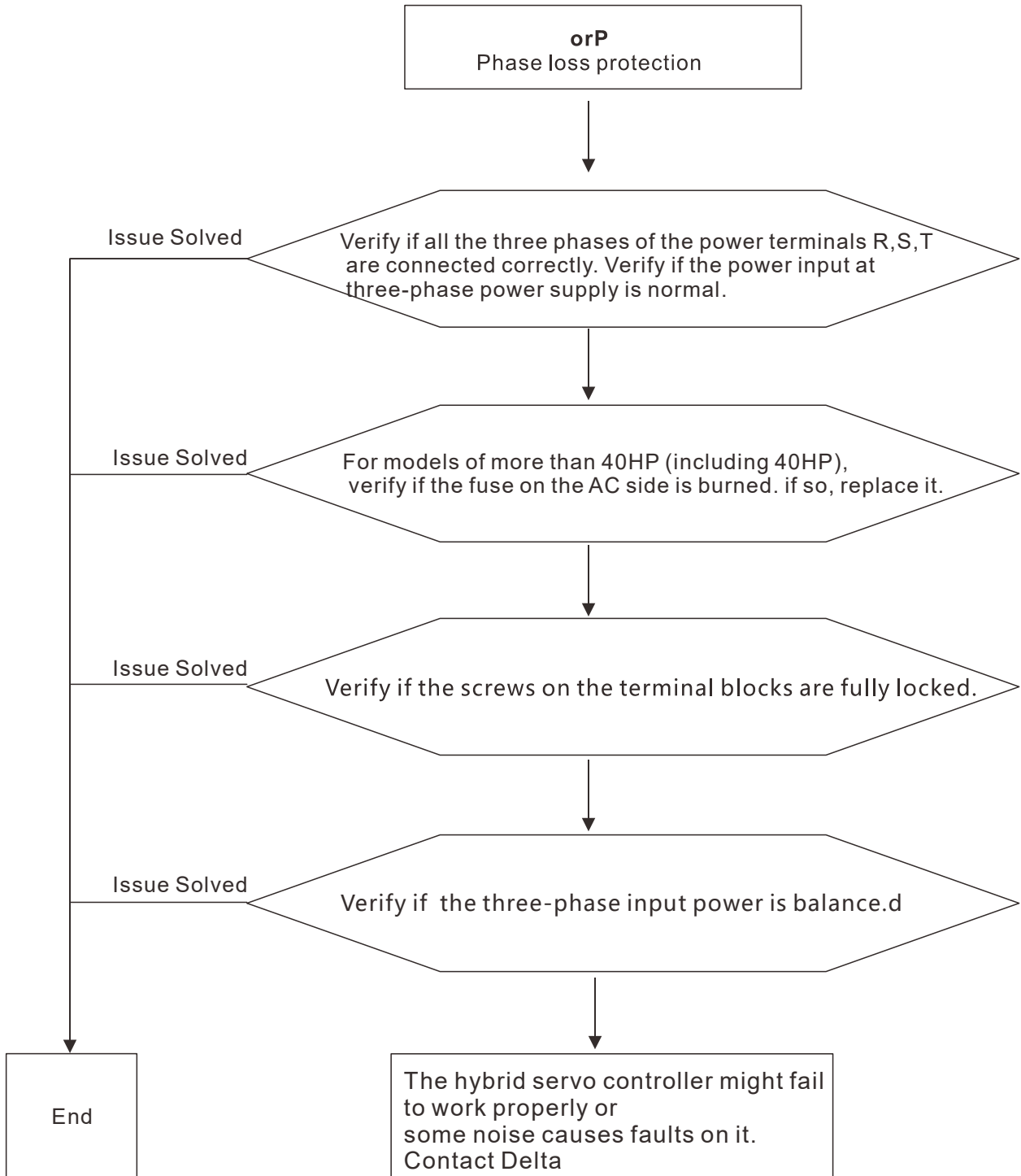

E16. oH1: IGBT's temperature exceeds the protection level

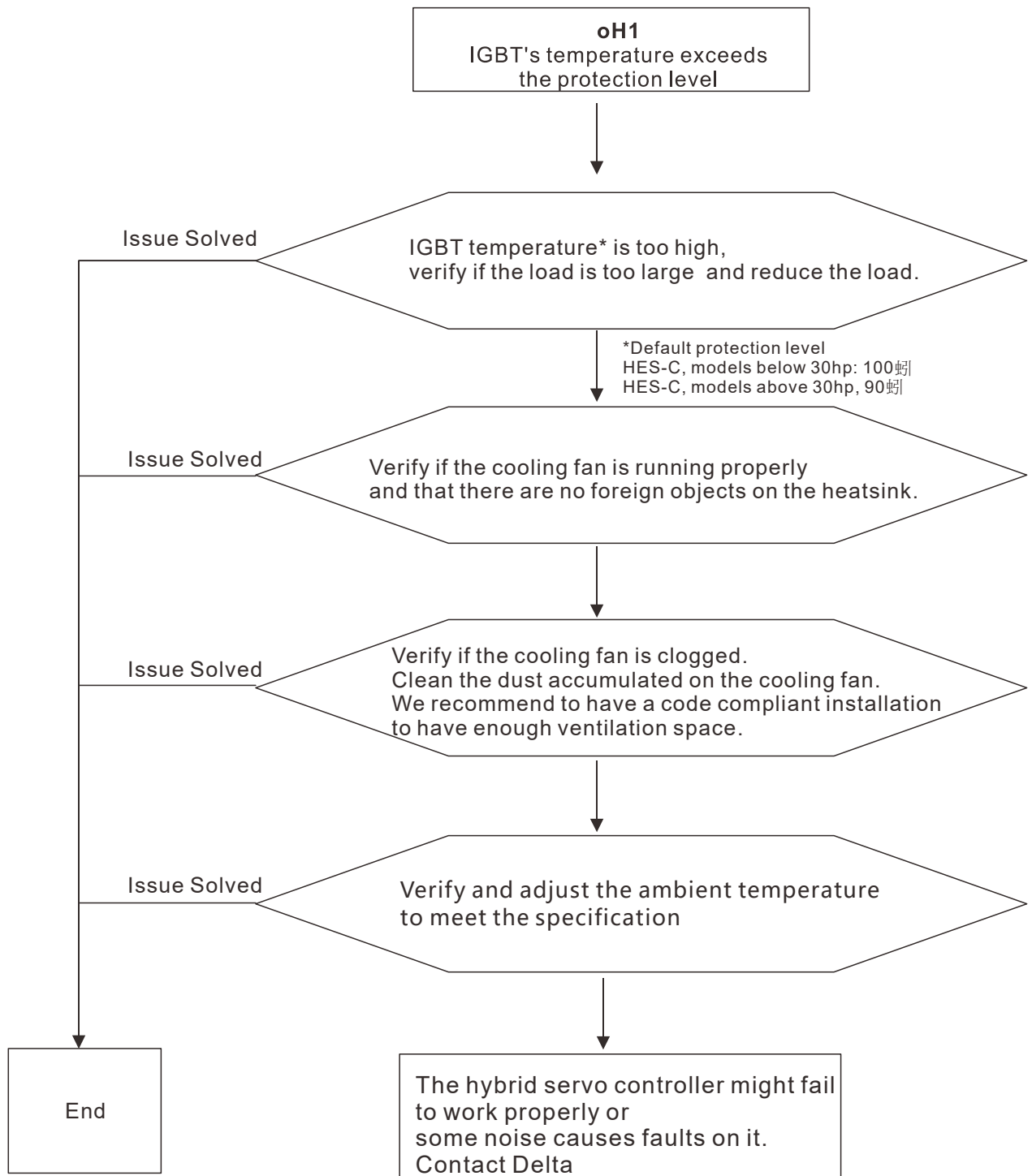

E17. oH2: Capacitor's temperature exceeds the protection level

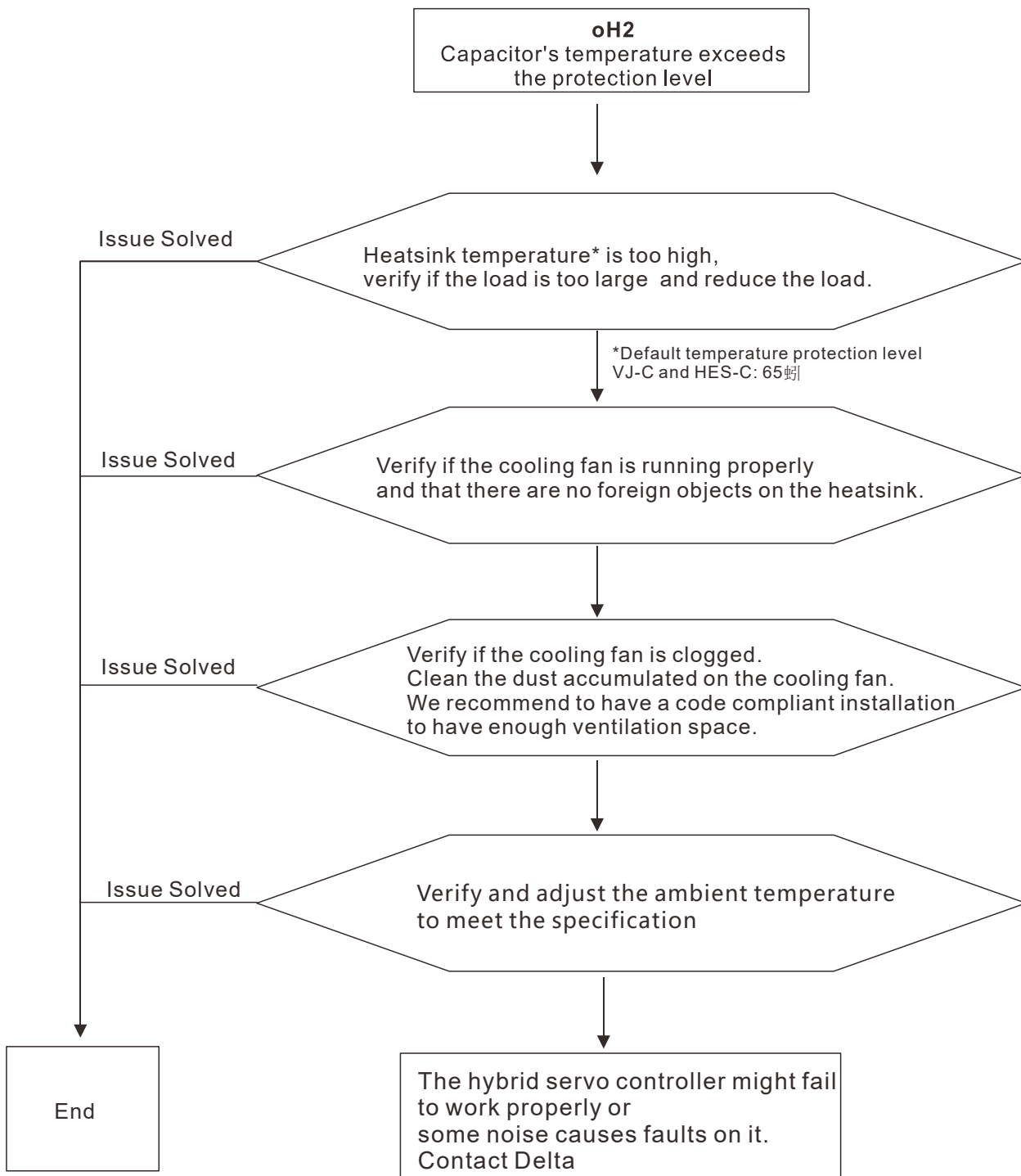

E18. tH1o: Hardware failure

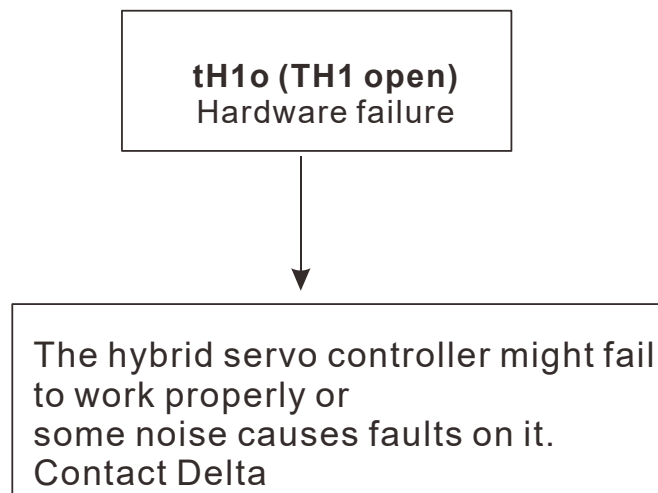

E19. tH2o: Hardware failure

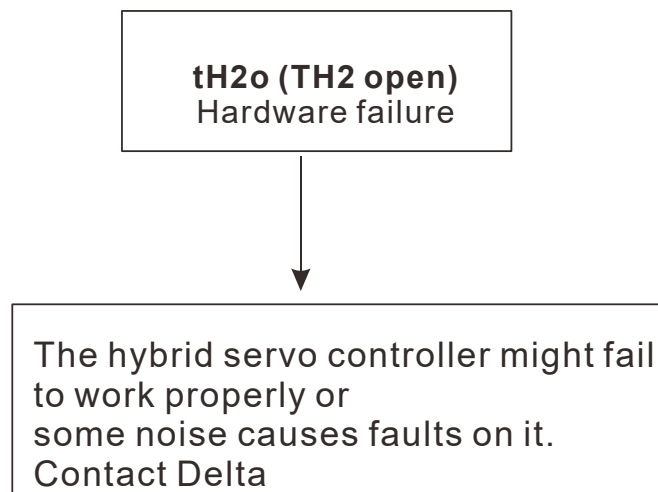

E20. oHF: IGBT overheated and cooling fan fails.

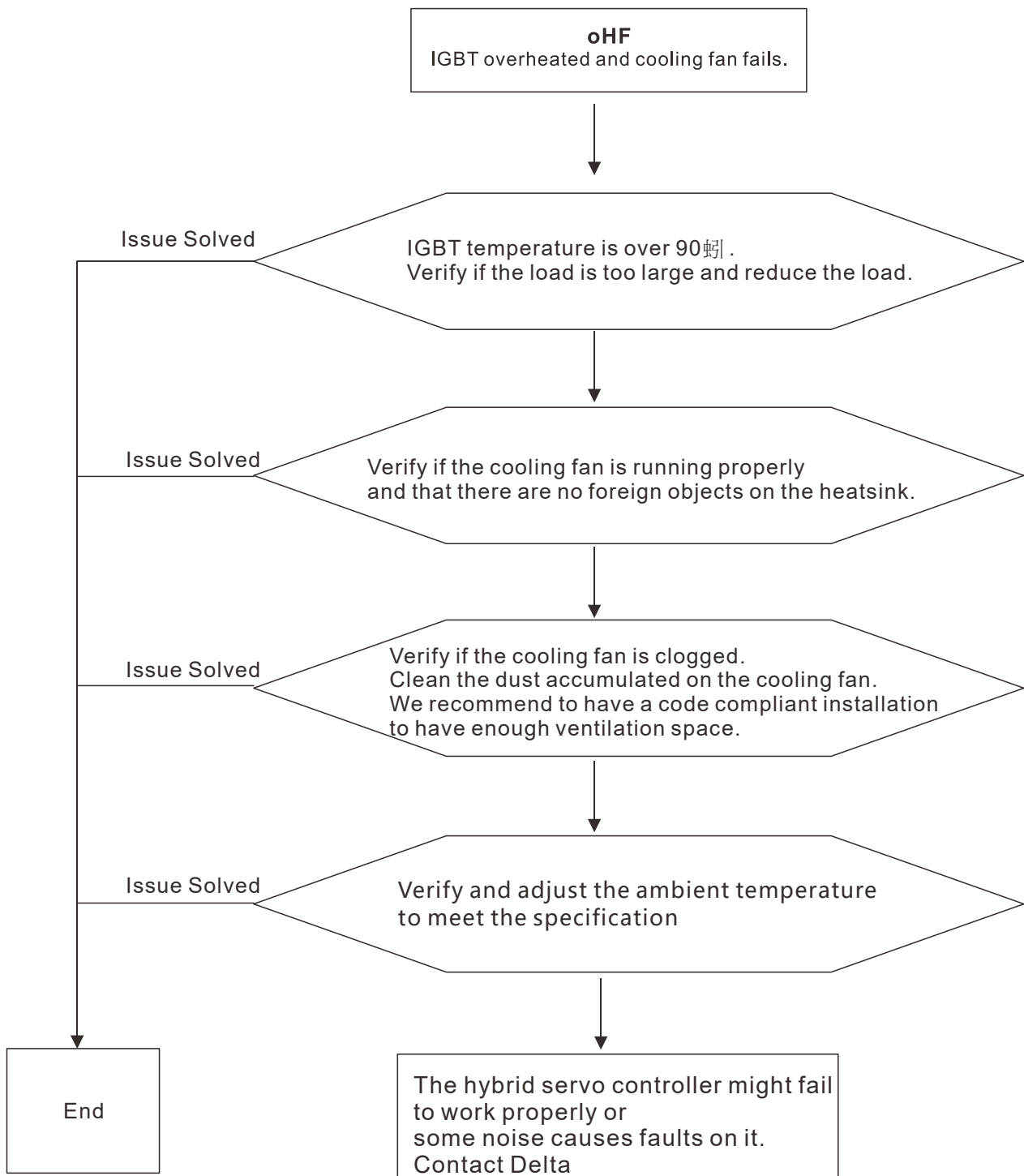

E21. oL: The hybrid motor drive or the hybrid servo controller detects excessive output current

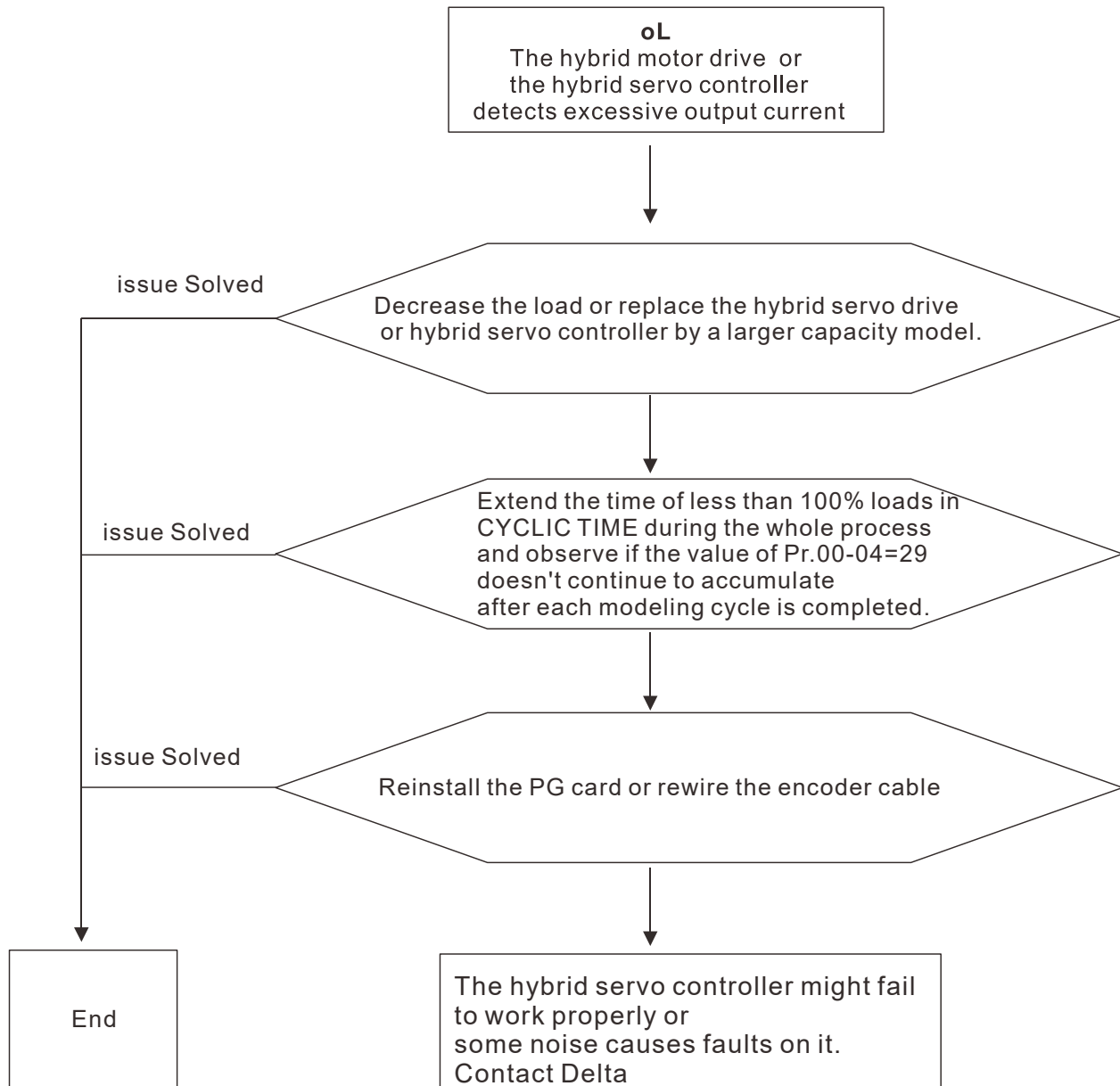

E24. oH3: High temperature on the motor exceeds the protection level (Pr.02-09 PTC level) detected by the hybrid servo drive

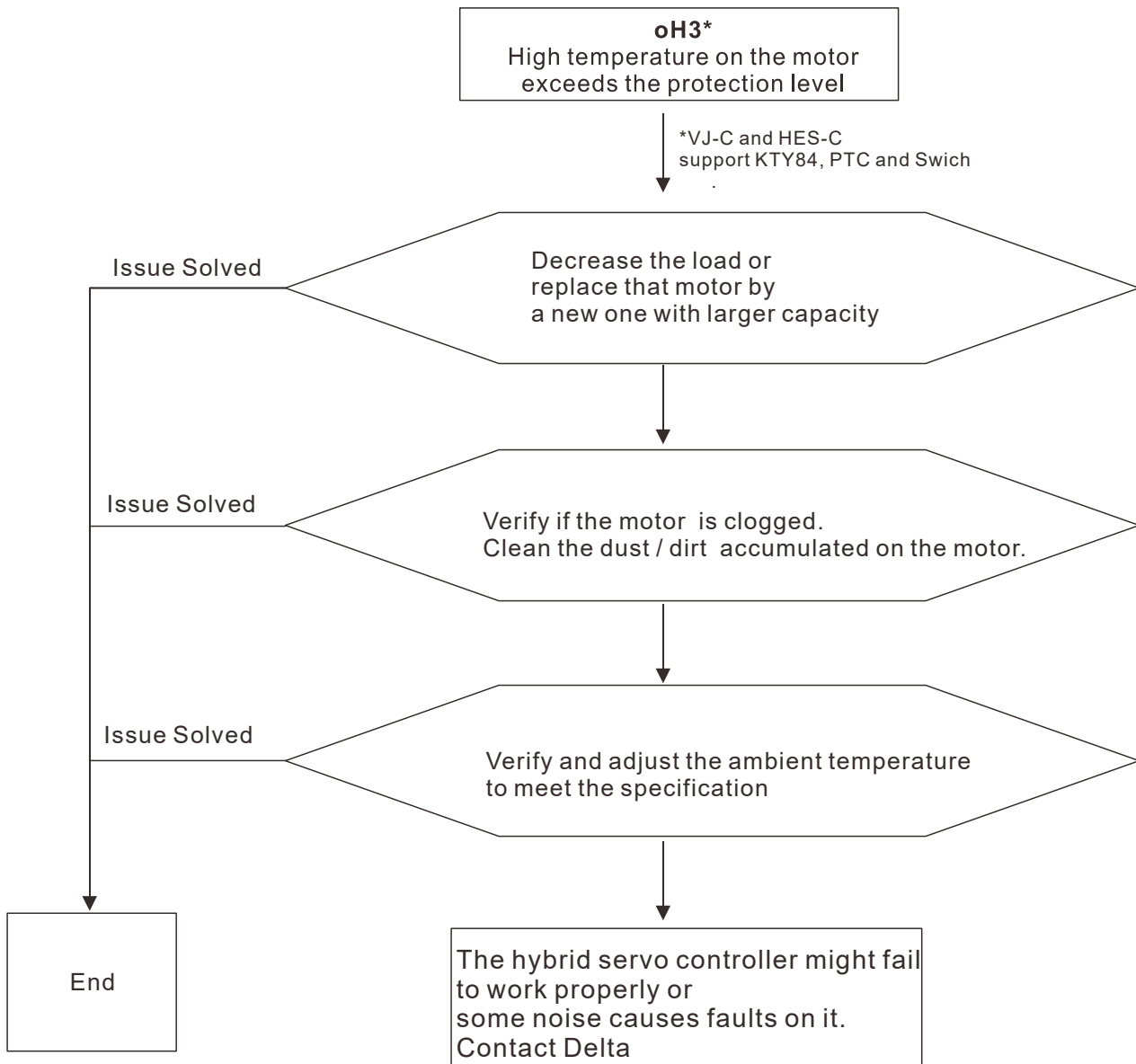

E30. cF1: Fault on memory write-in

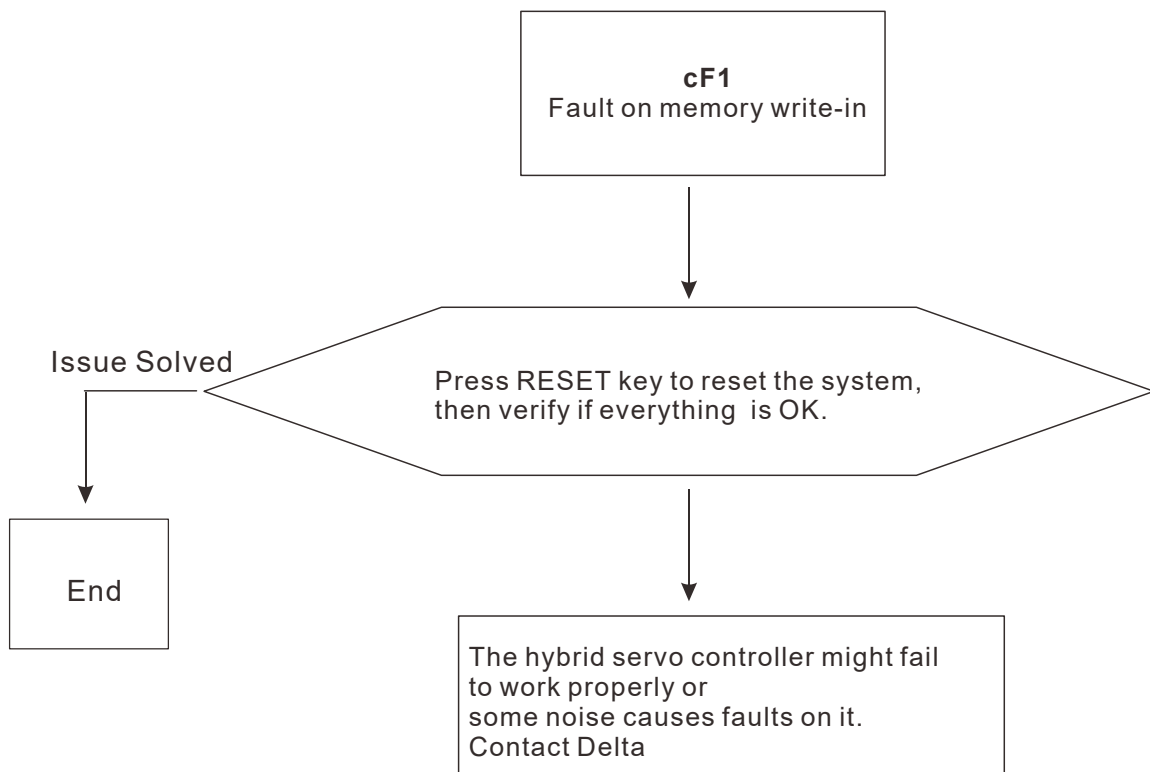

E31. cF2: Fault on memory read out:

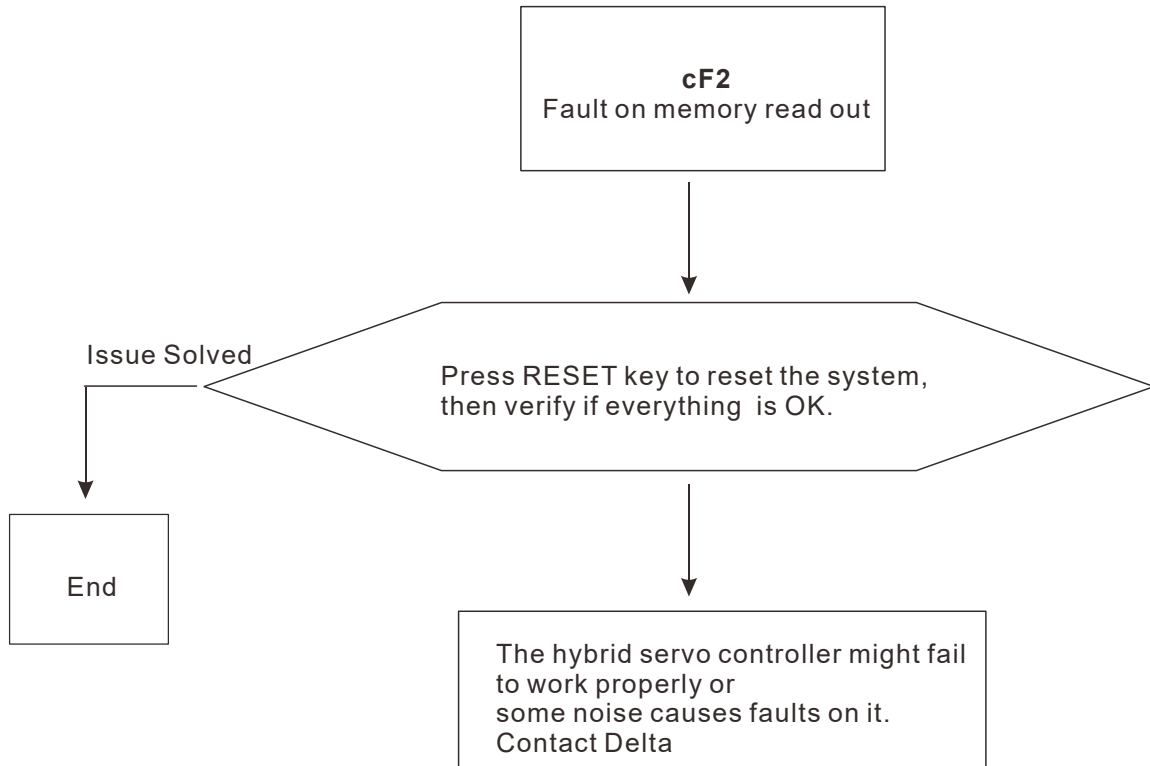

F32. cd0: Detection of abnormal output of three-phase total current

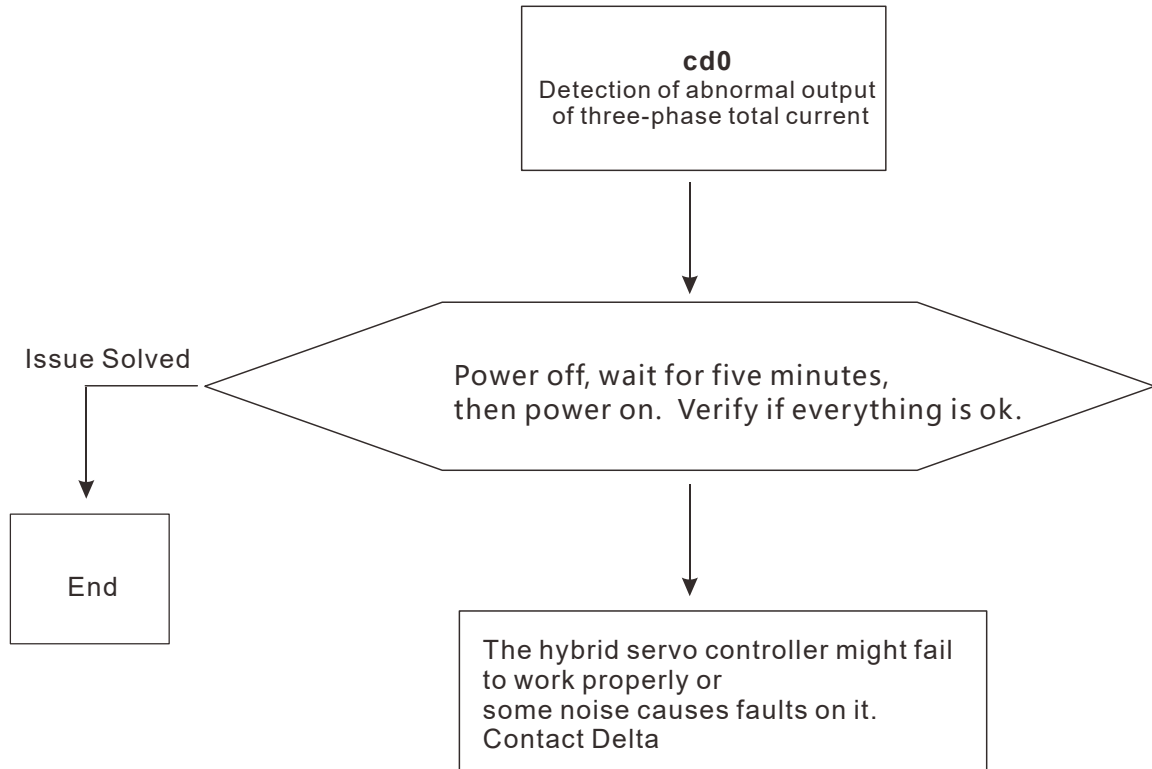

F33. cd1: Detection of abnormal current in phase U

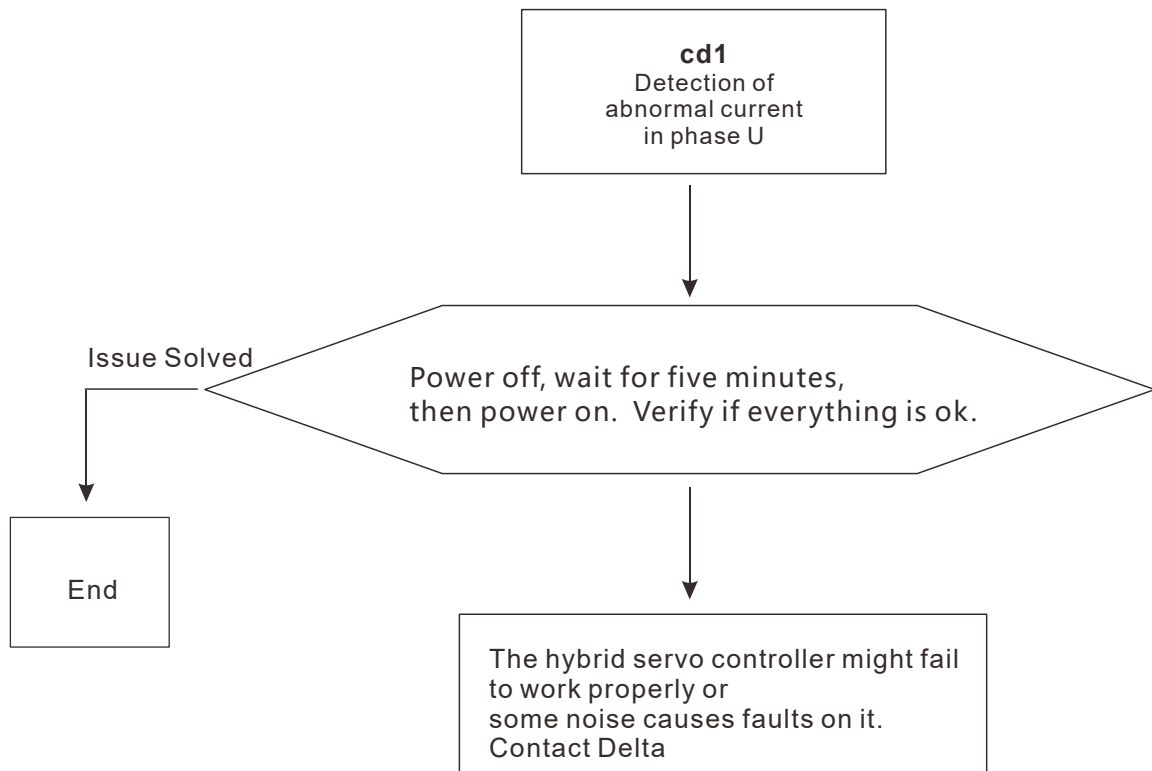

F34. cd2: Detection of abnormal current in phase V

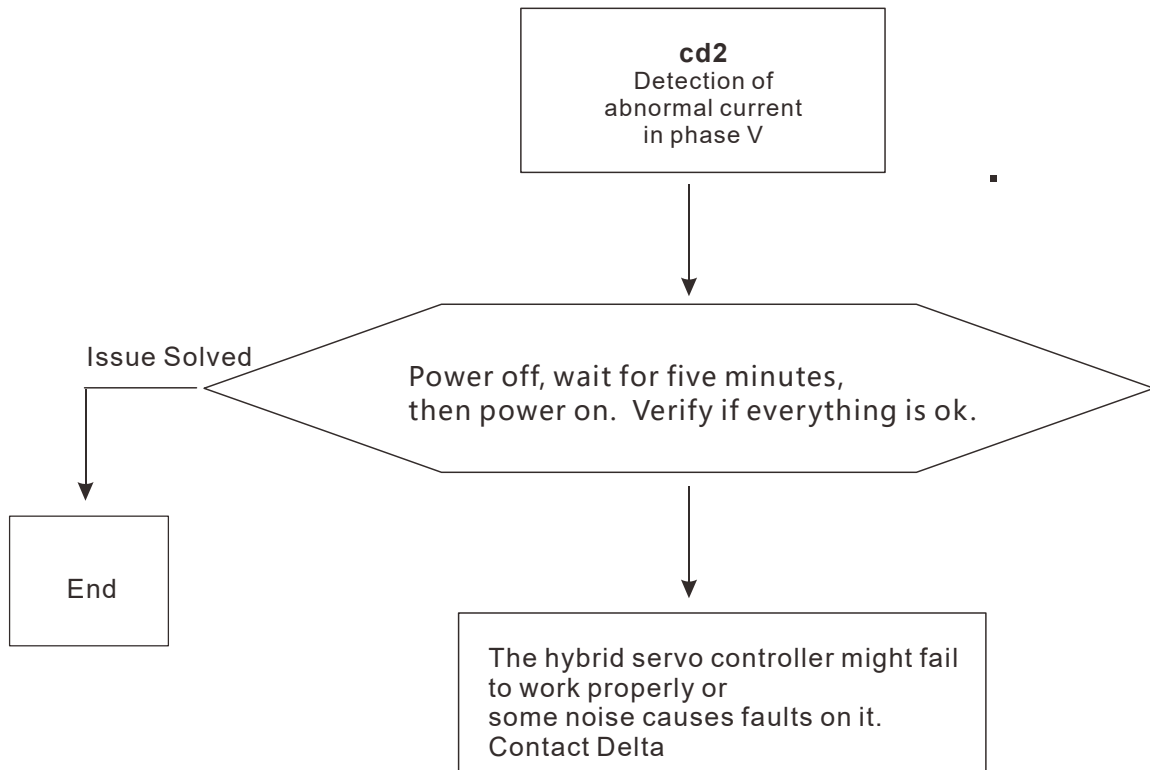

F35. cd3: Detection of abnormal current in phase W

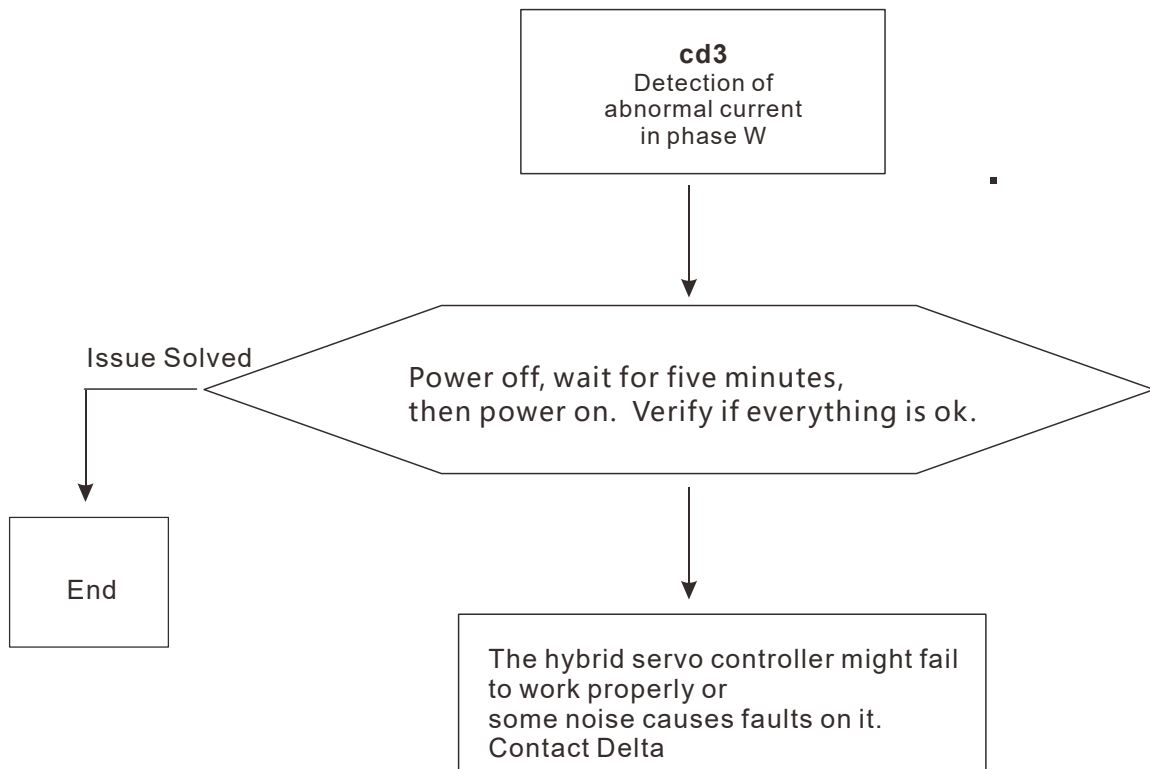

F36. Hd0: Clamp current detection fault

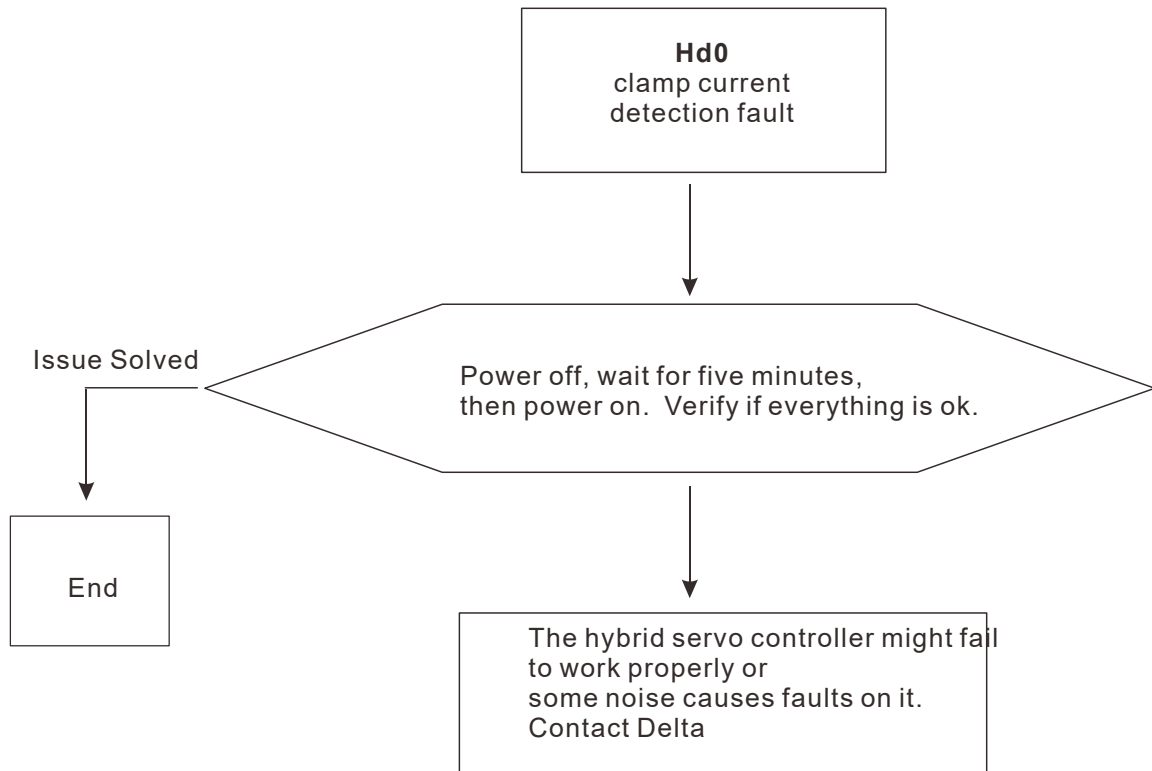

F37. Hd1: Over-current detection fault

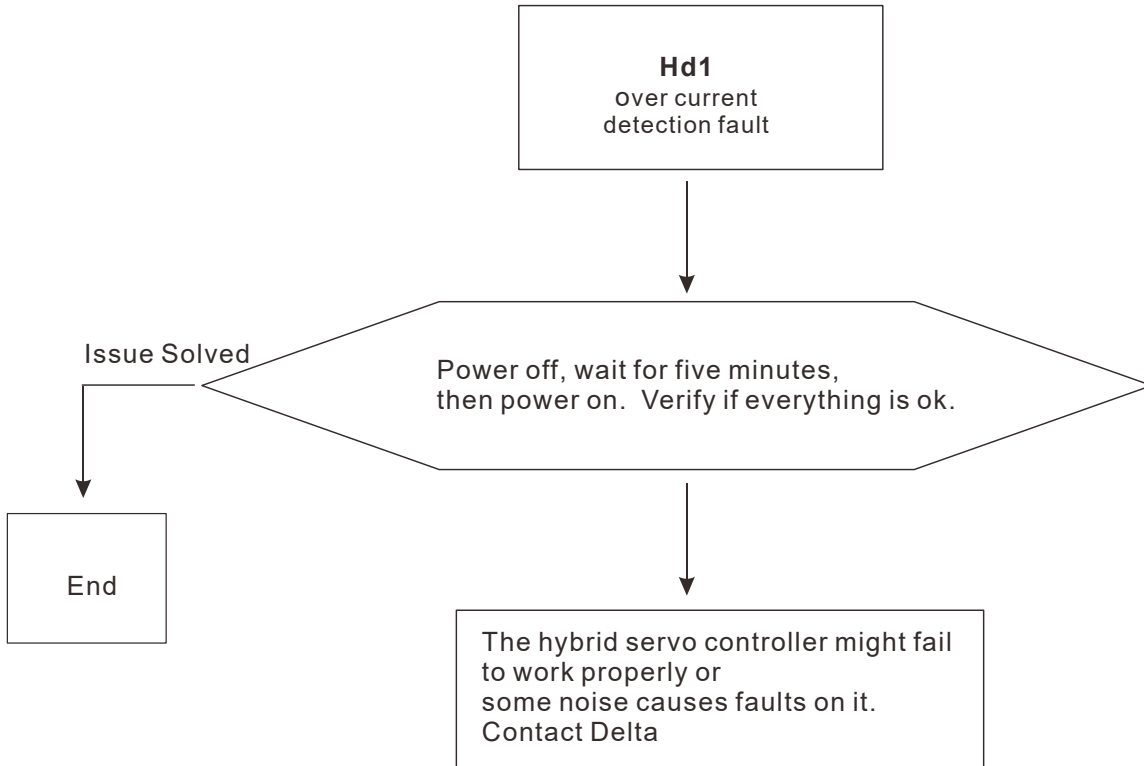

F38. Hd2: Over voltage detection fault

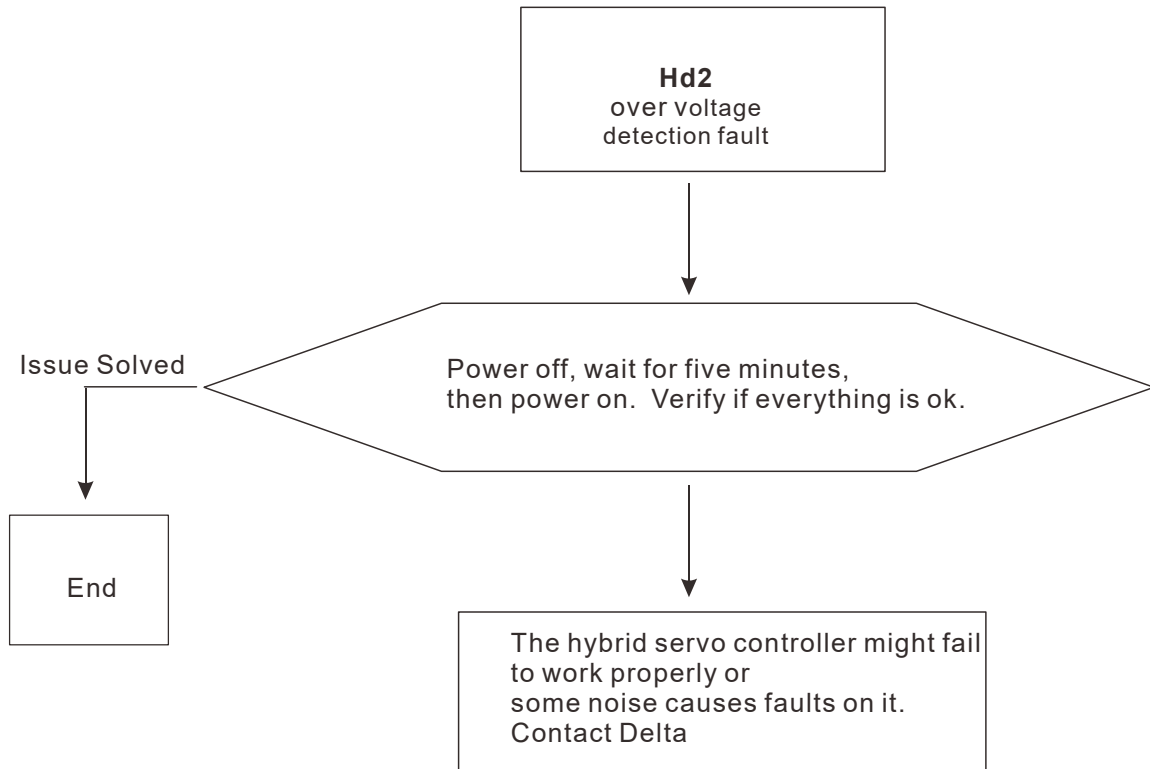

F39. Hd3: Ground current detection fault

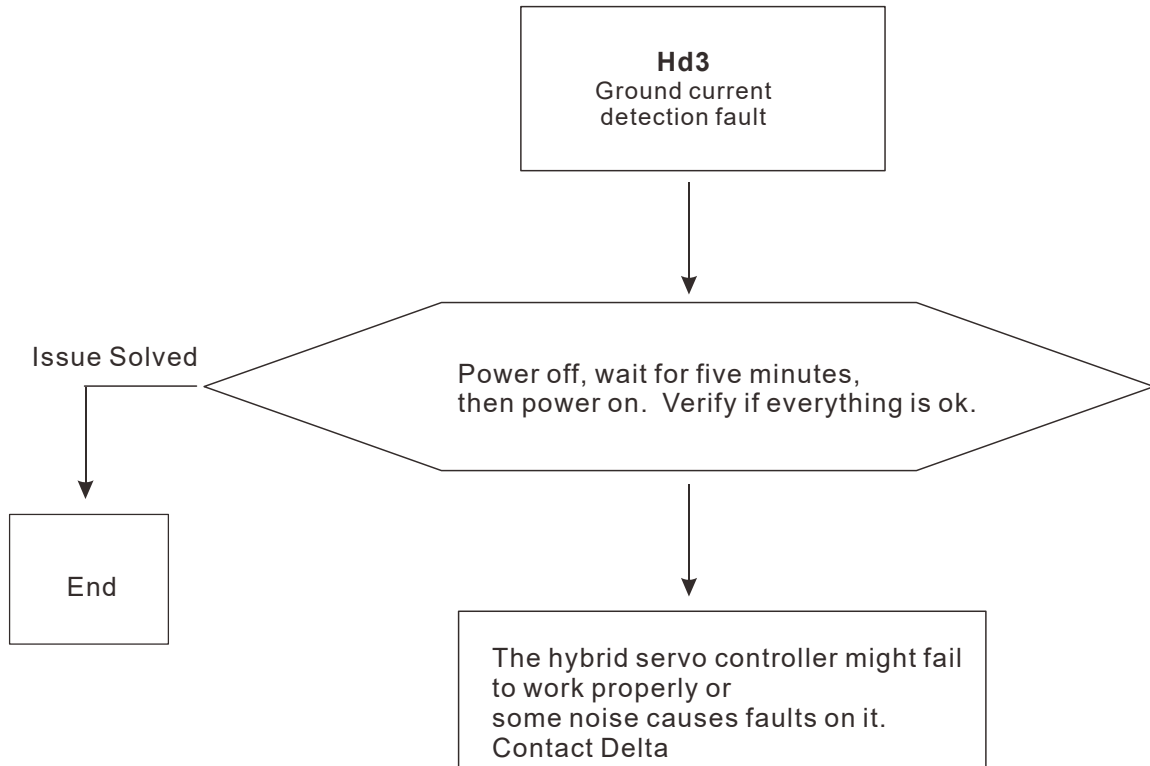

E42. PGF1: PG feedback fault

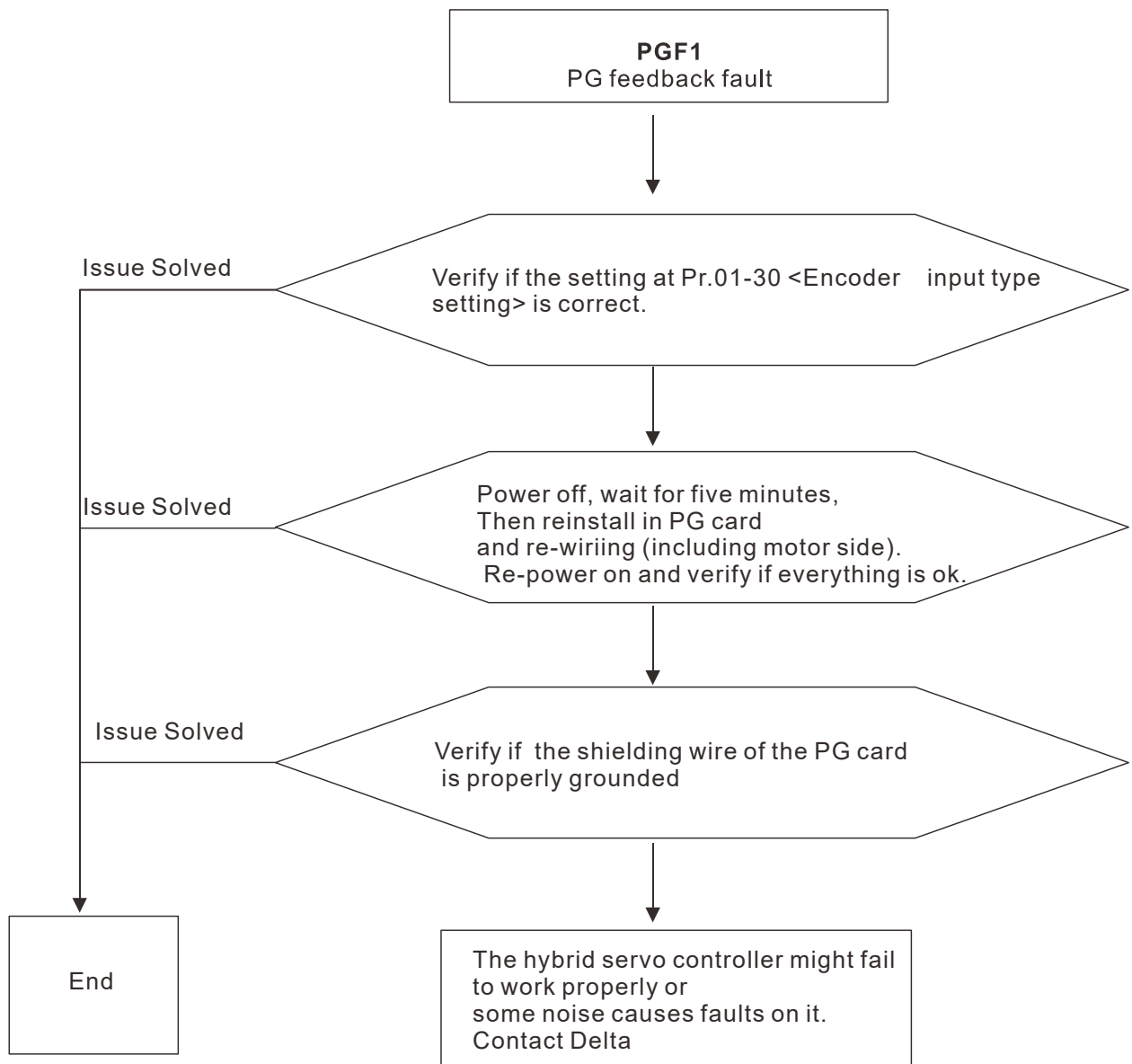

E43. PGF2: PG feedback loss

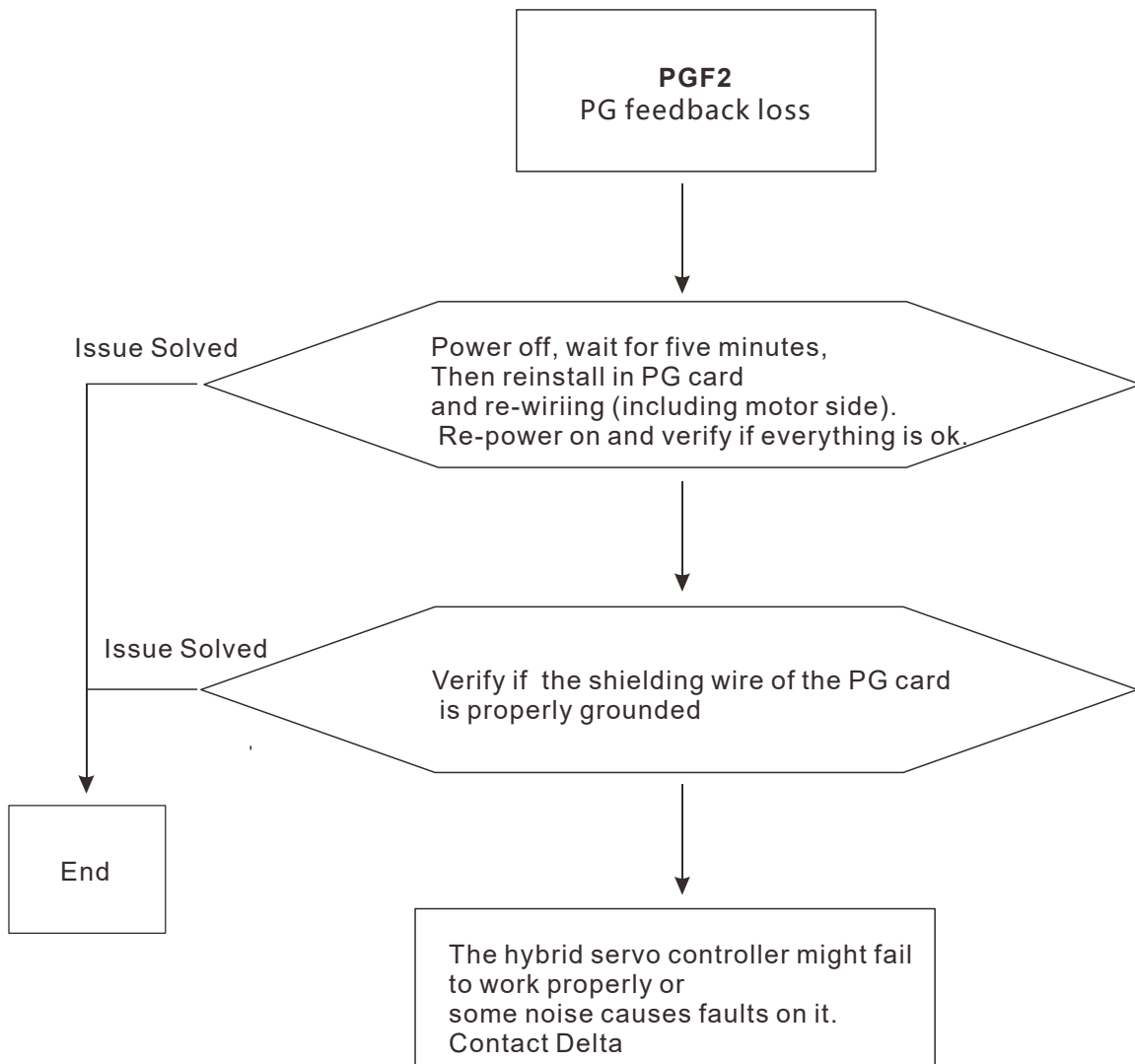

E44. PGF3: Stalled PG feedback

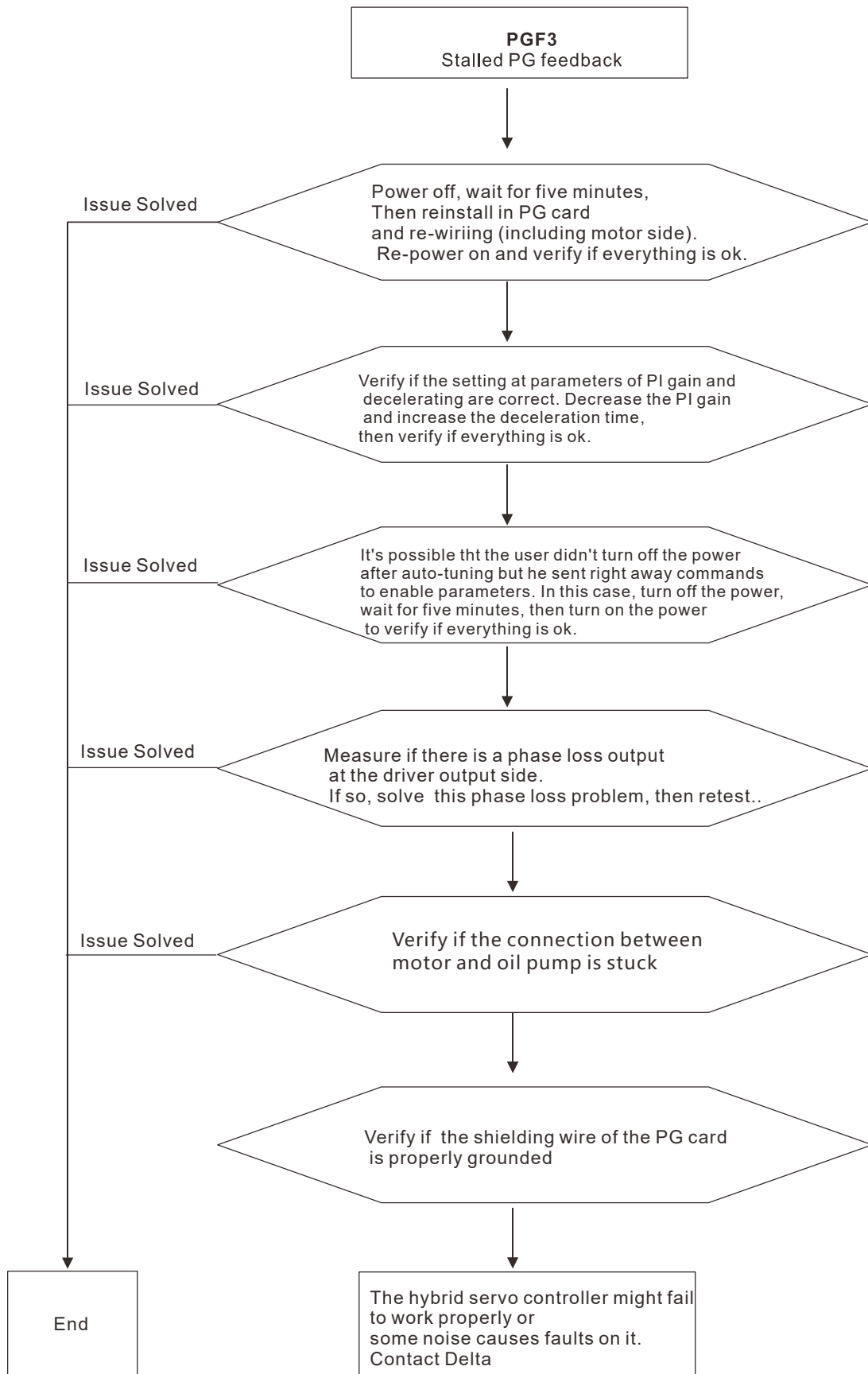

E45. PGF4: PG feedback slip

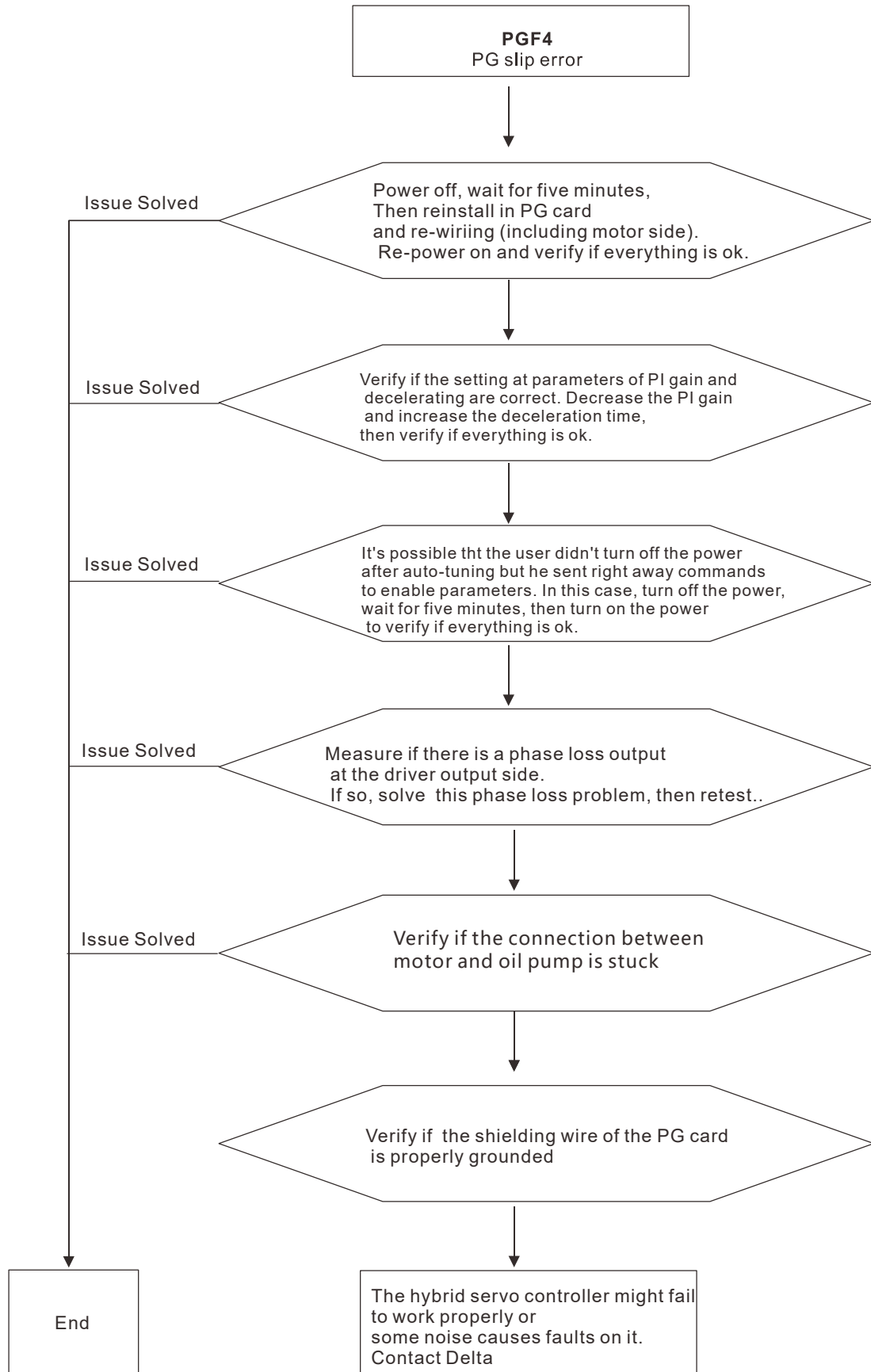

E49. EF: When external terminals EF are closed, hybrid servo controller stops its output

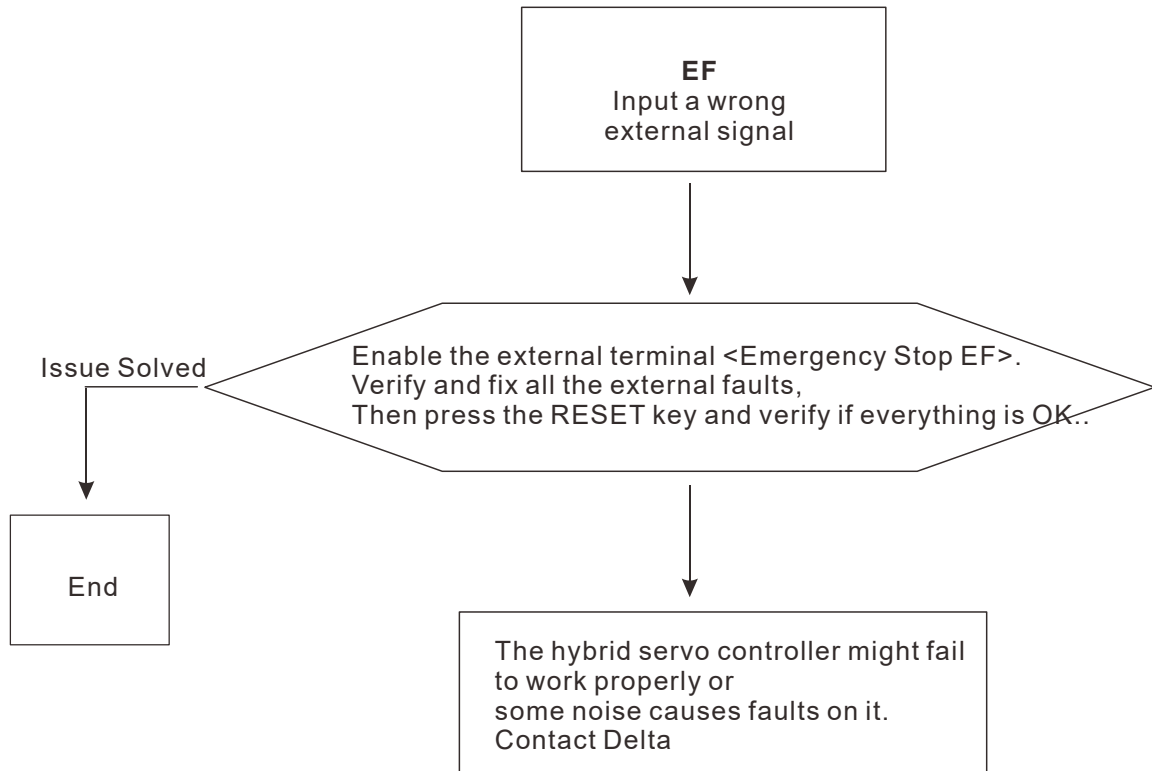

E50. EF1: When external terminals EMG is closed, hybrid servo controller stops its output

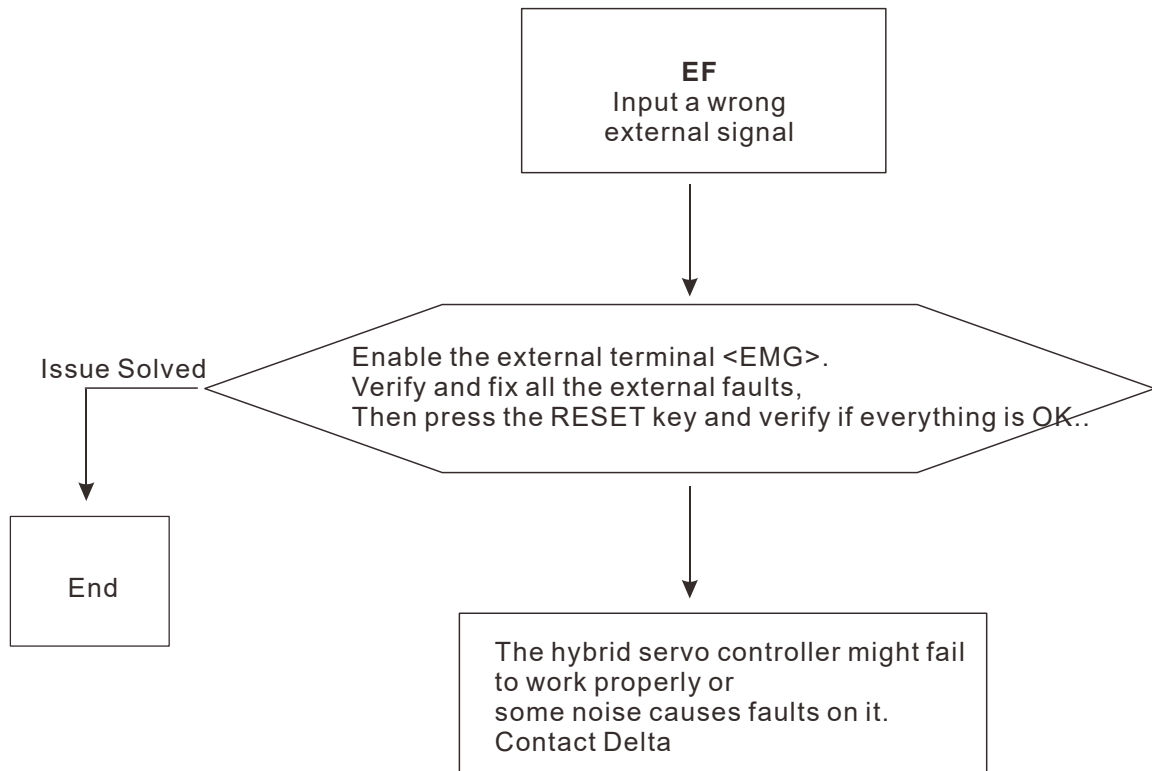

E60. bF: Brake transistor fault

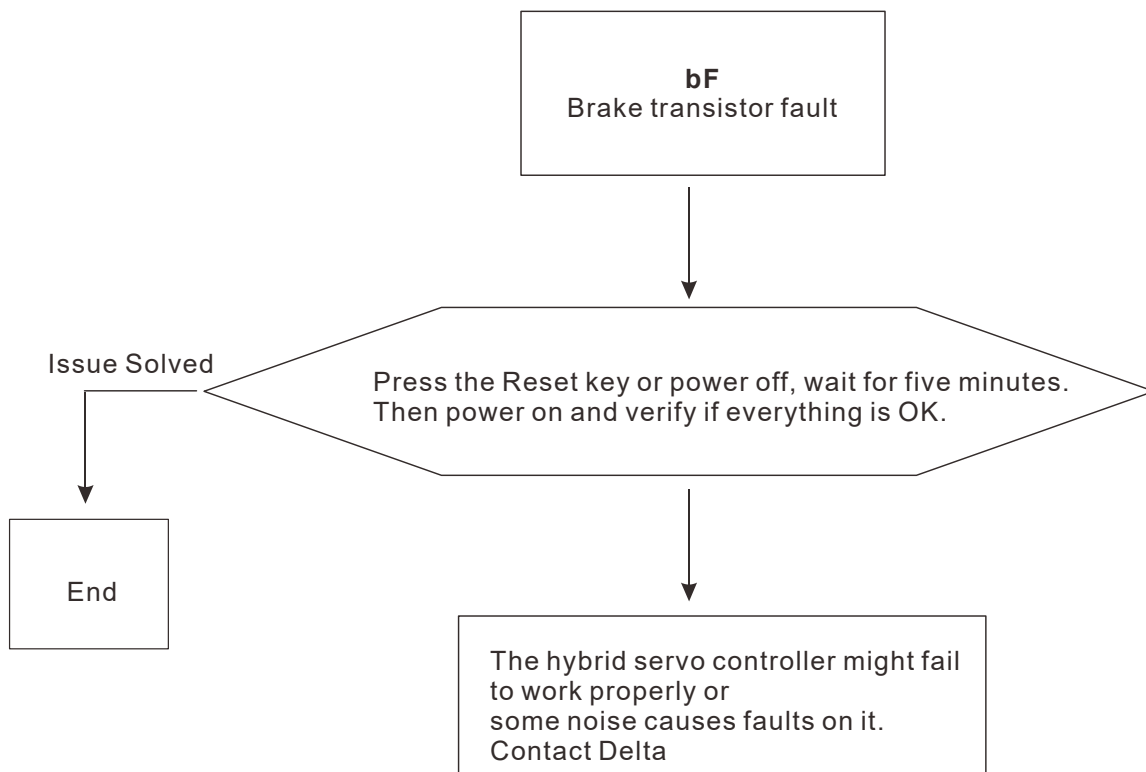

E65. PGF5: PG card hardware fault or magnetic pole tuning fault

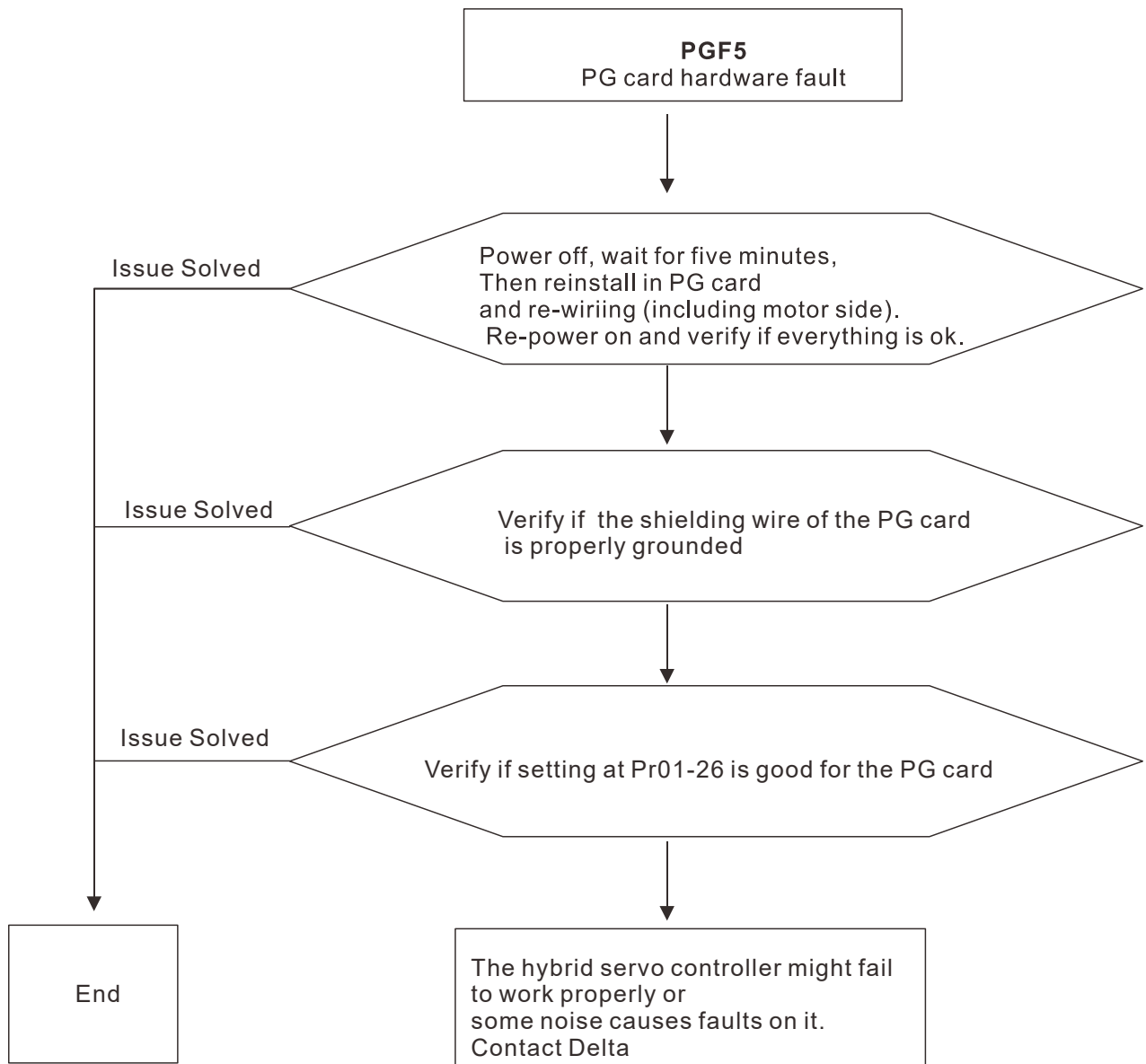

E66. ovP: Overpressure

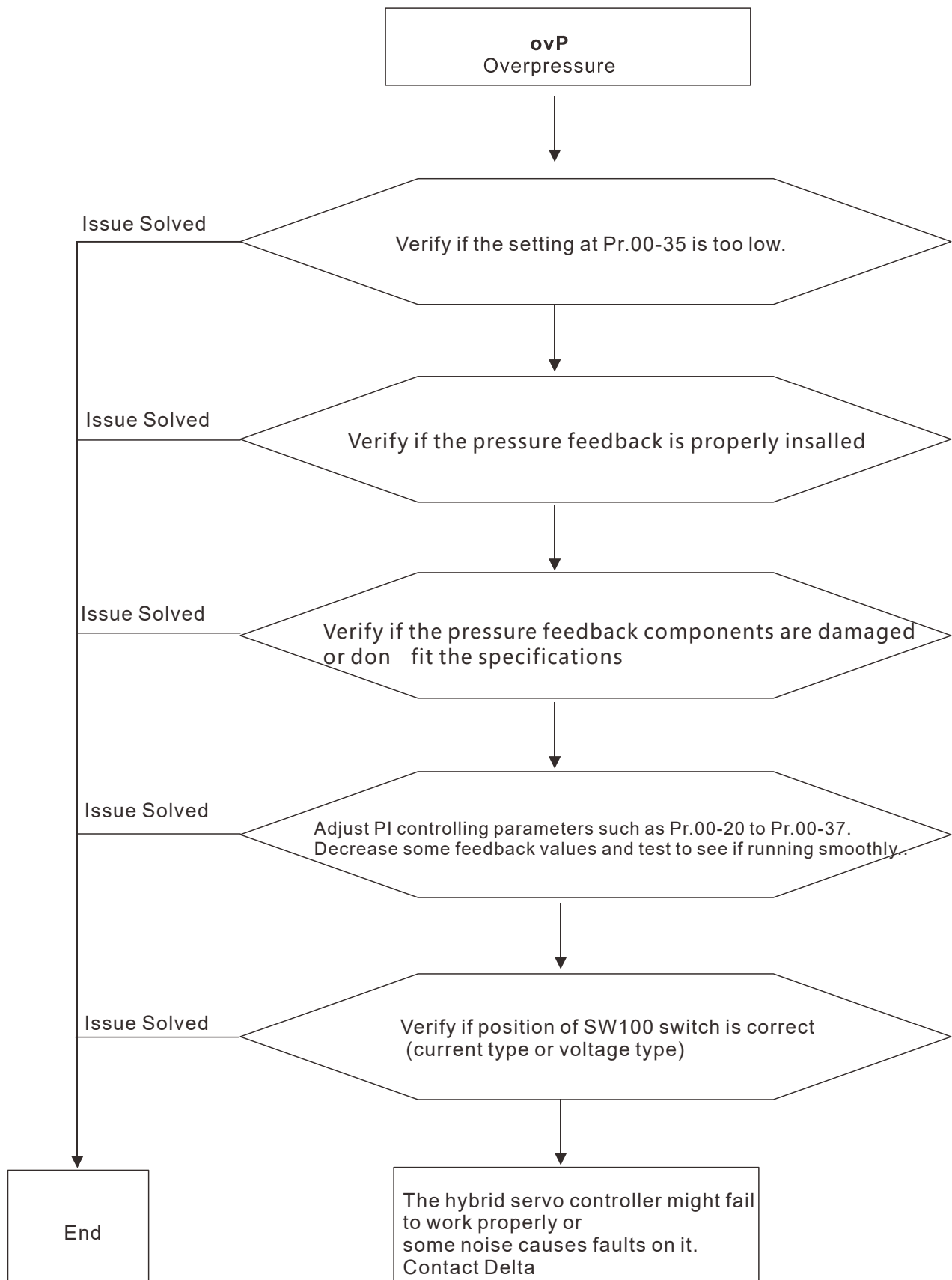

E67. PfbF: Pressure feedback fault

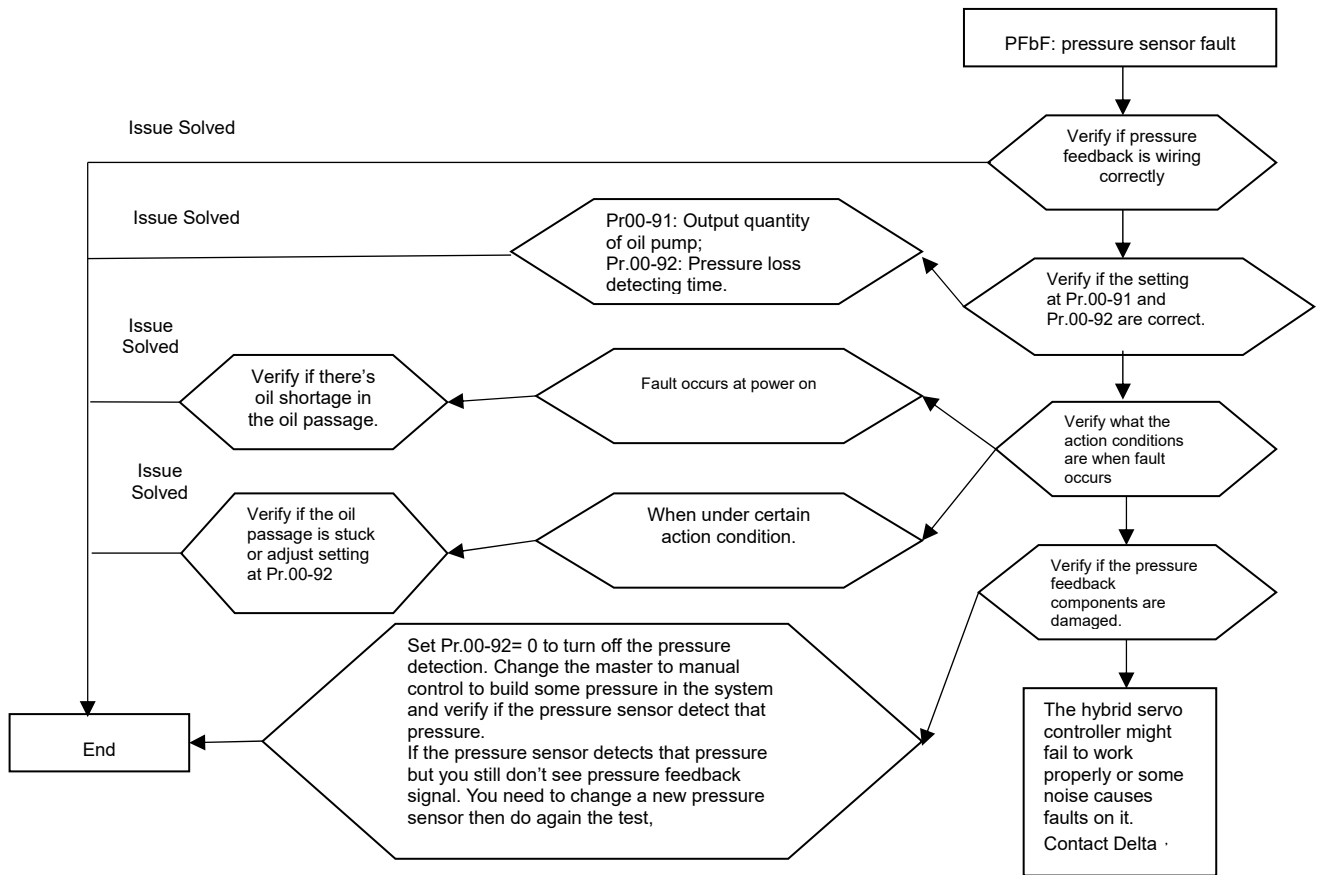

F73. brF: Braking resistor's resistance is too small.

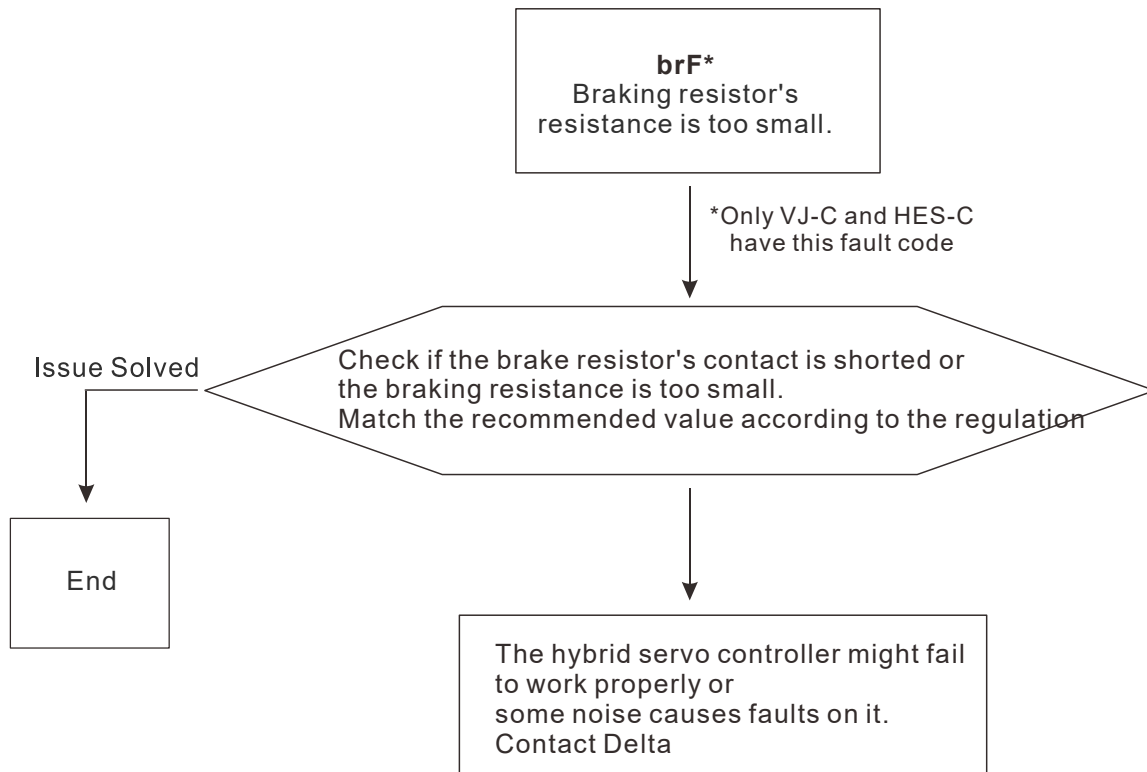

E74. oH4: Braking transistor overheated

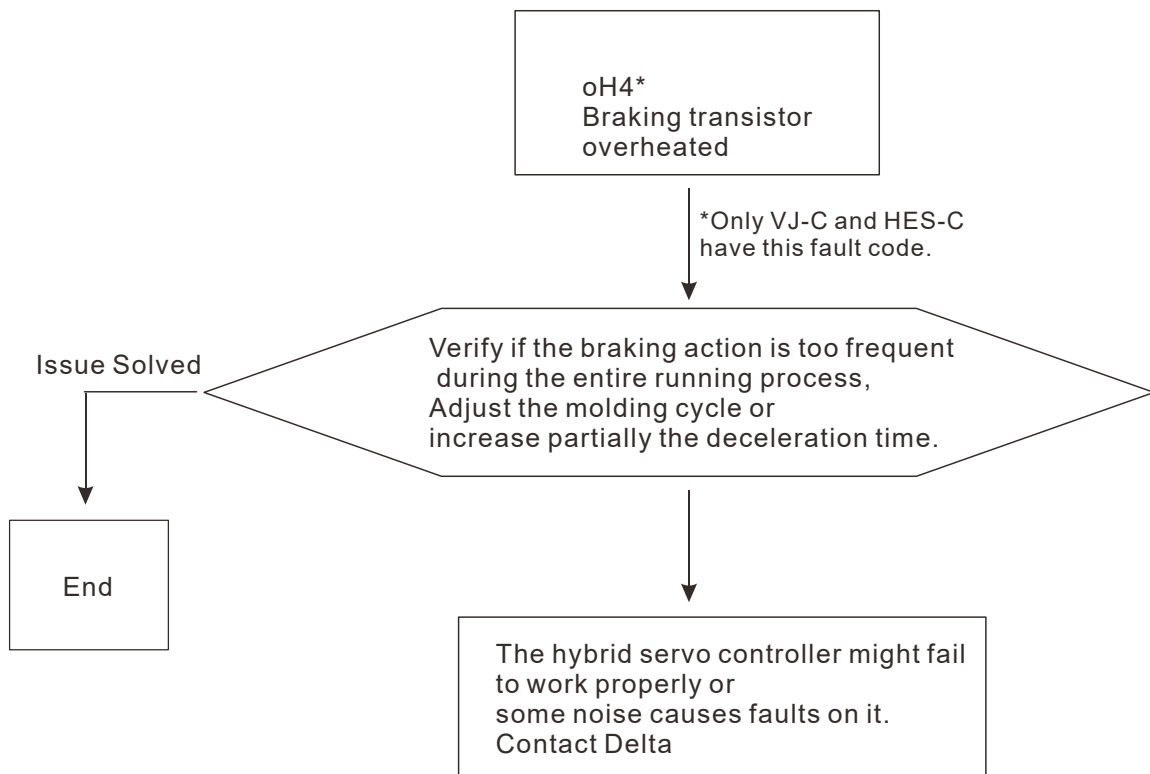

E87. oL3: Overloading servo controller while running at low frequency

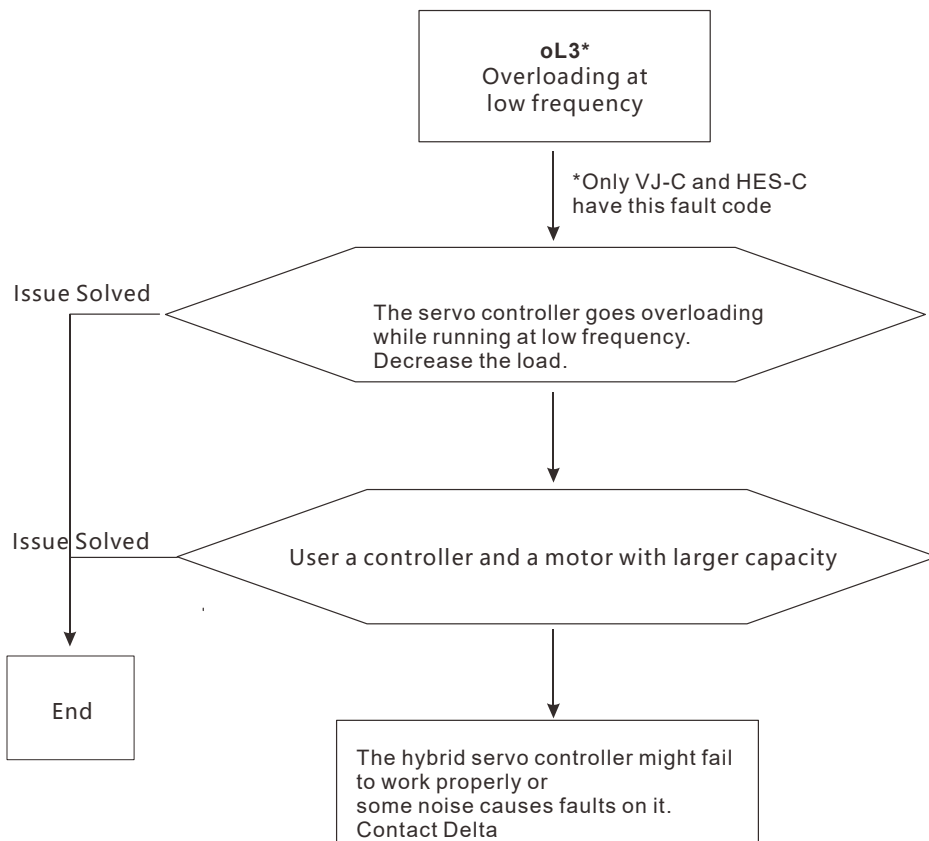

5-3 Resolution for electromagnetic noise and induction noise

If there exist noise sources around hybrid servo controller, they will affect hybrid servo controller through radiation or the power lines, leading to malfunction of control loop and causing tripping or even damage of hybrid servo controller. One natural solution is to make hybrid servo controller more immune to noise. However, it is not economical and the improvement is limited. It is best to resort to methods that achieve improvements outside hybrid servo controller.

1. Add surge killer on the relay or contact to suppress switching surge between ON/OFF.
2. Shorten the wiring length of the control circuit or serial circuit and separate from the main circuit wiring.
3. Comply with the wiring regulation for those shielded wire and use isolation amplifier for long wire.
4. The ground terminal of hybrid servo controller must be connected to ground by following the associated regulations. It must have its own ground connection and cannot share with electrical welder and other power equipment.
5. Insert noise filter to the input terminal of hybrid servo controller to prevent the noise entering from the power lines.

In a word, three-level solutions for electromagnetic noise are “no product”, “no spread” and “no receive”.

5-4 Environment and facilities for installation

The hybrid servo controller is a device for electronic components. Detailed descriptions of the environment suitable for its operation can be found in the specifications. If the listed regulations cannot be followed for any reason, there must be corresponding remedial measures or contingency solutions.

1. To prevent vibration, anti-vibration spacer is the last choice. The vibration tolerance must be within the specification. The vibration effect is equal to the mechanical stress and it cannot occur frequently, continuously or repeatedly to prevent damaging servo controller.
2. Store in a clean and dry location free from corrosive fumes/dust to prevent rustiness, poor contact. It also may cause short by low insulation in a humid location. The solution is to use both paint and dust-proof. For particular occasion, use the enclosure with whole-seal structure.
3. The ambient temperature must be just right. If the temperature is too high or too low, the lifetime and action reliability of electronic components will be affected. For semiconductor devices, once the conditions exceed the rated values, consequences associated with “damage” are expected. As a result, in addition to providing cooler and shades that block the direct sunlight that are aimed to achieve required ambient temperature, it is also necessary to perform cleaning and spot check the air filter in the storage tray of hybrid servo controller and the angle of cooling fan. Moreover, the microcomputer may not work at extremely temperature, space heater is needed for machines that are installed and operated in cold regions.
4. Avoid moisture and occurrence of condensation. If the hybrid servo controller is expected to be shut down for an extended period of time, be careful not to let condensation happen once the air conditioning is turned off. It is also preferred that the cooling equipment in the electrical room can also work as a dehumidifier.

Chapter 6 Suggestions and Error Corrections

- 6-1 Maintenance and Inspections
- 6-2 Greasy Dirt Problem
- 6-3 Fiber Dust Problem
- 6-4 Erosion Problem
- 6-5 Industrial Dust Problem
- 6-6 Wiring and Installation Problem
- 6-7 Multi-function Input/Output Terminals Problem
- 6-8 Maintenance of Coupling

The hybrid servo controller is made up by numerous components, such as electronic components, including IC, resistor, capacity, transistor, and cooling fan, relay, etc. These components can't be used permanently. They have limited-life even under normal operation. Preventive maintenance is required to operate this hybrid servo controller in its optimal condition, and to ensure a long life.

Check your hybrid servo controller regularly to ensure there are no abnormalities during operation and follows the precautions:



- Wait 5 seconds after a fault has been cleared before performing reset via keypad of input terminal.
 - When the power is off after 5 minutes for $\leq 22\text{kW}$ models and 10 minutes for $\geq 30\text{kW}$ models, please confirm that the capacitors have fully discharged by measuring the voltage between + and -. The voltage between + and - should be less than $25V_{DC}$.
 - Only qualified personnel can install, wire and maintain drives. Please take off any metal objects, such as watches and rings, before operation. And only insulated tools are allowed.
 - Never reassemble internal components or wiring.
 - Make sure that installation environment comply with regulations without abnormal noise, vibration and smell.
-

6-1 Maintenance and Inspections

Before the check-up, always turn off the AC input power and remove the cover. Wait at least 10 minutes after all display lamps have gone out, and then confirm that the capacitors have fully discharged by measuring the voltage between DC+ and DC-. The voltage between DC+ and DC- should be less than $25V_{DC}$.

Ambient environment

Check Items	Methods and Criterion	Maintenance Period		
		Daily	Half Year	One Year
Check the ambient temperature, humidity, vibration and see if there are any dust, gas, oil or water drops	Visual inspection and measurement with equipment with standard specification	<input type="radio"/>		
If there are any dangerous objects	Visual inspection	<input type="radio"/>		

Voltage

Check Items	Methods and Criterion	Maintenance Period		
		Daily	Half Year	One Year
Check if the voltage of main circuit and control circuit is correct	Measure with multimeter with standard specification	<input type="radio"/>		

Digital Keypad Display

Check Items	Methods and Criterion	Maintenance Period		
		Daily	Half Year	One Year
Is the display clear for reading	Visual inspection	<input type="radio"/>		
Any missing characters	Visual inspection	<input type="radio"/>		

Mechanical parts

Check Items	Methods and Criterion	Maintenance Period		
		Daily	Half Year	One Year
If there is any abnormal sound or vibration	Visual and aural inspection		<input type="radio"/>	
If there are any loose screws	Tighten the screws		<input type="radio"/>	
If any part is deformed or damaged	Visual inspection		<input type="radio"/>	
If there is any color change by overheating	Visual inspection		<input type="radio"/>	
If there is any dust or dirt	Visual inspection		<input type="radio"/>	
If plastic between couplings are damaged	Visual inspection			<input type="radio"/>

Main circuit

Check Items	Methods and Criterion	Maintenance Period		
		Daily	Half Year	One Year
If there are any loose or missing screws	Tighten or replace the screw	<input type="radio"/>		
If machine or insulator is deformed, cracked, damaged or with color change due to overheating or ageing	Visual inspection NOTE: Please ignore the color change of copper plate		<input type="radio"/>	
If there is any dust or dirt	Visual inspection		<input type="radio"/>	

Terminals and wiring of main circuit

Check Items	Methods and Criterion	Maintenance Period		
		Daily	Half Year	One Year
If the terminal or the plate is color change or deformation due to overheat	Visual inspection		<input type="radio"/>	
If the insulator of wiring is damaged or color change	Visual inspection		<input type="radio"/>	
If there is any damage	Visual inspection	<input type="radio"/>		

DC capacity of main circuit

Check Items	Methods and Criterion	Maintenance Period		
		Daily	Half Year	One Year
If there is any leak of liquid, color change, crack or deformation	Visual inspection	<input type="radio"/>		
If the safety valve is not removed? If valve is inflated?	Visual inspection	<input type="radio"/>		
Measure static capacity when required		<input type="radio"/>		

Resistor of main circuit

Check Items	Methods and Criterion	Maintenance Period		
		Daily	Half Year	One Year
If there is any peculiar smell or insulator cracks due to overheat	Visual inspection, smell	<input type="radio"/>		
If there is any disconnection	Visual inspection	<input type="radio"/>		
If connection is damaged?	Measure with multimeter with standard specification	<input type="radio"/>		

Transformer and reactor of main circuit

Check Items	Methods and Criterion	Maintenance Period		
		Daily	Half Year	One Year
If there is any abnormal vibration or peculiar smell	Visual, aural inspection and smell	<input type="radio"/>		

Magnetic contactor and relay of main circuit

Check Items	Methods and Criterion	Maintenance Period		
		Daily	Half Year	One Year
If there are any loose screws	Visual and aural inspection	<input type="radio"/>		
If the contact works correctly	Visual inspection	<input type="radio"/>		

Printed circuit board and connector of main circuit

Check Items	Methods and Criterion	Maintenance Period		
		Daily	Half Year	One Year
If there are any loose screws and connectors	Tighten the screws and press the connectors firmly in place.		<input type="radio"/>	
If there is any peculiar smell and color change	Visual and smell inspection		<input type="radio"/>	
If there is any crack, damage, deformation or corrosion	Visual inspection		<input type="radio"/>	
If there is any liquid is leaked or deformation in capacity	Visual inspection		<input type="radio"/>	

Cooling fan of cooling system

Check Items	Methods and Criterion	Maintenance Period		
		Daily	Half Year	One Year
If there is any abnormal sound or vibration	Visual, aural inspection and turn the fan with hand (turn off the power before operation) to see if it rotates smoothly		<input type="radio"/>	
If there is any loose screw	Tighten the screw		<input type="radio"/>	
If there is any color change due to overheat	Change fan		<input type="radio"/>	

Ventilation channel of cooling system

Check Items	Methods and Criterion	Maintenance Period		
		Daily	Half Year	One Year
If there is any obstruction in the heat sink, air intake or air outlet	Visual inspection		○	

 **NOTE**

Please use the neutral cloth for clean and use dust cleaner to remove dust when necessary.

6-2 Greasy Dirt Problem

Serious greasy dirt problems generally occur in processing industries such as machine tools, punching machines and so on. Please be aware of the possible damages that greasy oil may cause to your drive:

1. Electronic components that silt up with greasy oil may cause the drive to burn out or even explode.
2. Most greasy dirt contains corrosive substances that may damage the drive.

Solution:

Install the hybrid servo controller in a standard cabinet to keep it away from dirt. Clean and remove greasy dirt regularly to prevent damage of the drive.

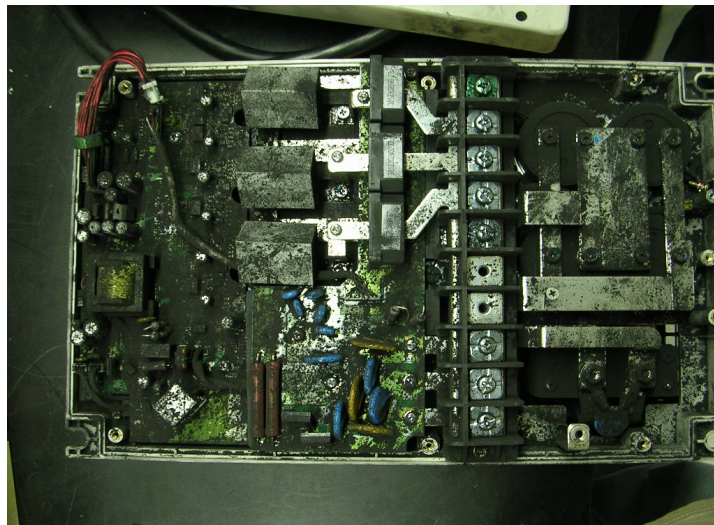

6-3 Fiber Dust Problem

Serious fiber dust problems generally occur in the textile industry. Please be aware of the possible damages that fiber may cause to your drives:

1. Fiber that accumulates or adheres to the fans will lead to poor ventilation and cause overheating problems.
2. Plant environments in the textile industry have higher degrees of humidity that may cause the drive to burn out, become damaged or explode due to wet fiber dust adhering to the devices.

Solution:

Install the hybrid servo controller in a standard cabinet to keep it away from fiber dust. Clean and remove fiber dust regularly to prevent damage to the drive.

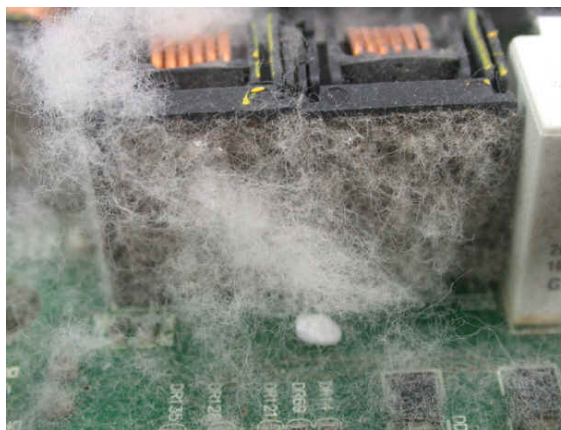

6-5 Industrial Dust Problem

Serious industrial dust pollution frequently occurs in stone processing plants, flour mills, cement plants, and so on. Please be aware of the possible damage that industrial dust may cause to your drives:

1. Dust accumulating on electronic components may cause overheating problem and shorten the service life of the drive.
2. Conductive dust may damage the circuit board and may even cause the drive to explode.

Solution:

Install the hybrid servo controller in a standard cabinet and cover the drive with a dust cover. Clean the cabinet and ventilation hole regularly for good ventilation.

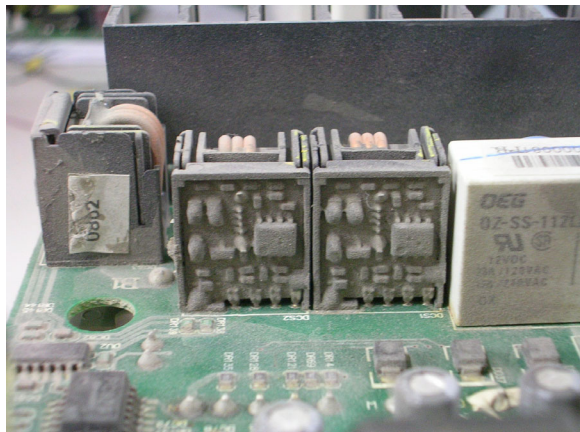

Check Items	Methods and Criterion	Troubleshooting
Visual check on the overall appearance	<ul style="list-style-type: none"> Any accumulation of dirt and dust? 	<ol style="list-style-type: none"> Shut down the servo controller, wait for a certain time. Make sure that the power indicator is off before you go to the next step. ($\leq 22\text{kW}$: wait for 5 min after shut down; $\geq 30\text{kW}$: wait for 10 min after shut down) Turn on a vacuum cleaner to remove the dust.
Ventilation Channel	<ul style="list-style-type: none"> Any obstruction in the heat sink, air intake or air outlet? Any accumulation of dust on the cooling fan? Is the cooling fan damaged? 	<ol style="list-style-type: none"> Shut down the servo controller, wait for a certain time. Make sure that the power indicator is off before you go to the next step. ($\leq 22\text{kW}$: wait for 5 min after shut down; $\geq 30\text{kW}$: wait for 10 min after shut down) Follow the instruction in this manual to remove and clean the cooling fan. Turn on a vacuum cleaner to clean the dust in the heat sink. ° <ul style="list-style-type: none"> If the cooling fan doesn't run at all, replace it with a new one. Clean the ventilation channel periodically to avoid accumulation of dirt and dust.

● Install and Remove Cooling Fans

Frame-C & Frame-D

- Use a phillips-head screw driver to loose the two screws on the two sides of the cooling fan.
- Press the latch to disconnect the fan power. Pay attention to the direction of the latch during installation. Then remove the fan cover.

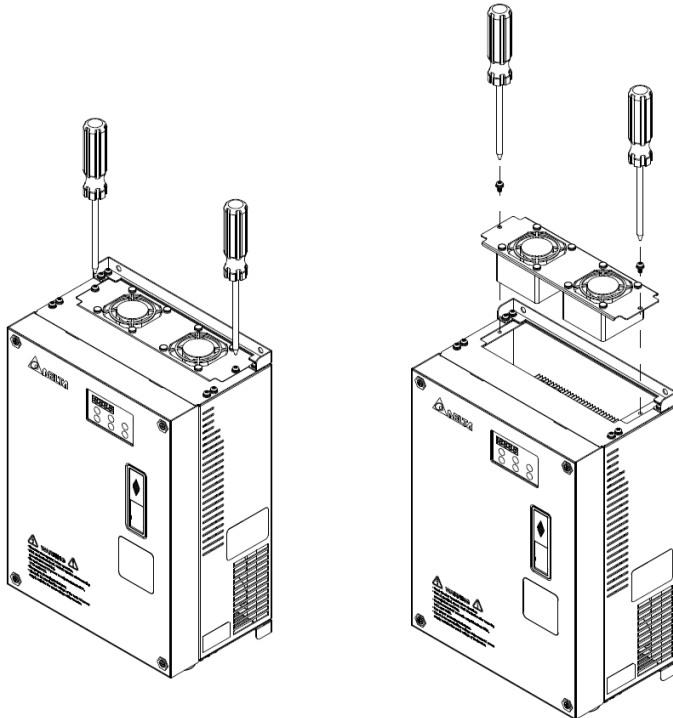

- Press the 4 latches on the fan cover, then you can remove the fan. Note that you don't need to pull up completely the latches to remove the fans. Just press gently.

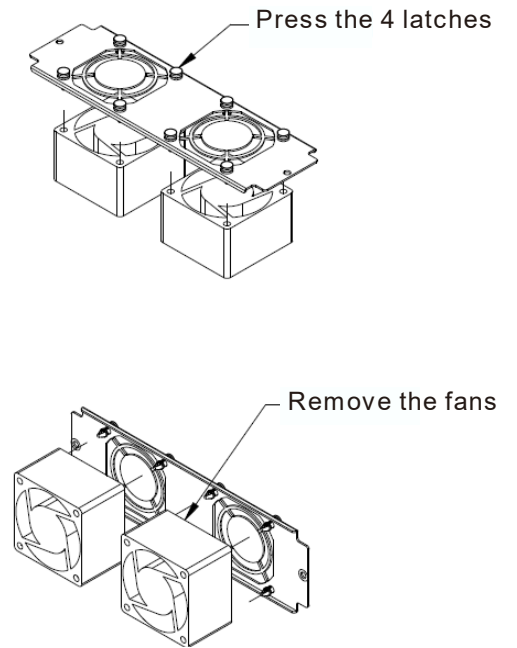

- Have the labels on the cooling fans facing outside of the servo controller when installing the cooling fans. Screw torque force: 10~12kgf-cm(8.7~10.4lb-in)

Frame-E

- Use a philillips-head screw driver to loose the 4 screws on the two sides of the cooling fan.
- Press the latch to disconnect the fan power. Pay attention to the direction of the latch during installation. Then remove the fan cover.

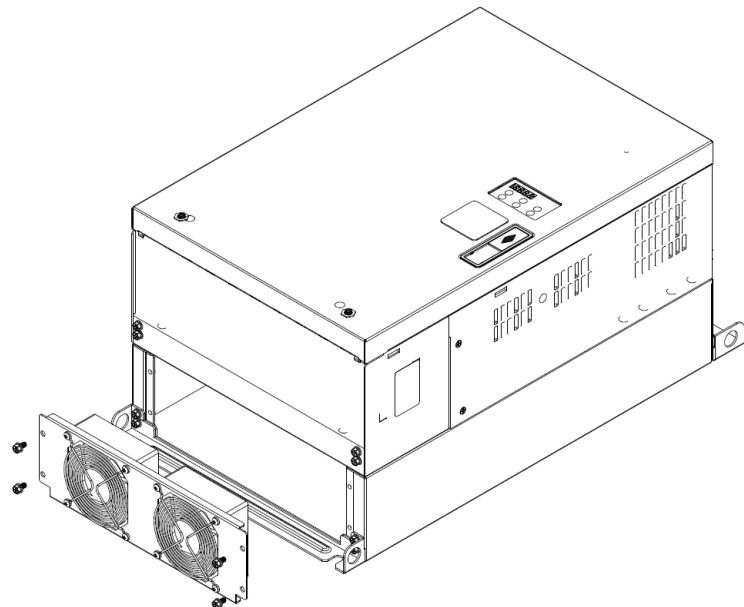

- Loosen the 4 screws around each fan (8 screws in total), then remove the protective cover and the fan.

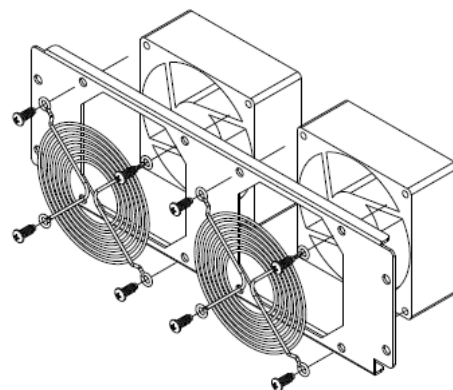

- Have the labels on the cooling fans facing inside of the servo controller when installing the cooling fans. Screw torque force: 10~12kgf-cm (8.7~10.4lb-in)

 **NOTE**

- Do follow the fan installing/ removing instructions in this manual. Make sure the air outlet is facing the right direction. If air outlet is facing the wrong direction, the servo controller might be damaged.
- You can see arrow symbols indicating the air blowing direction on the side of the cooling fans.

6-6 Wiring and Installation Problem

When wiring the drive, the most common problem is wrong wire installation or poor wiring. Please be aware of the possible damages that poor wiring may cause to your drives:

1. Screws are not fully fastened. Occurrence of sparks as impedance increases.
2. If a customer has opened the drive and modified the internal circuit board, the internal components may have been damaged.

Solution:

Ensure all screws are fastened when installing the hybrid servo controller. If the hybrid servo controller functions abnormally, send it back to the repair station. **DO NOT** try to reassemble the internal components or wire.

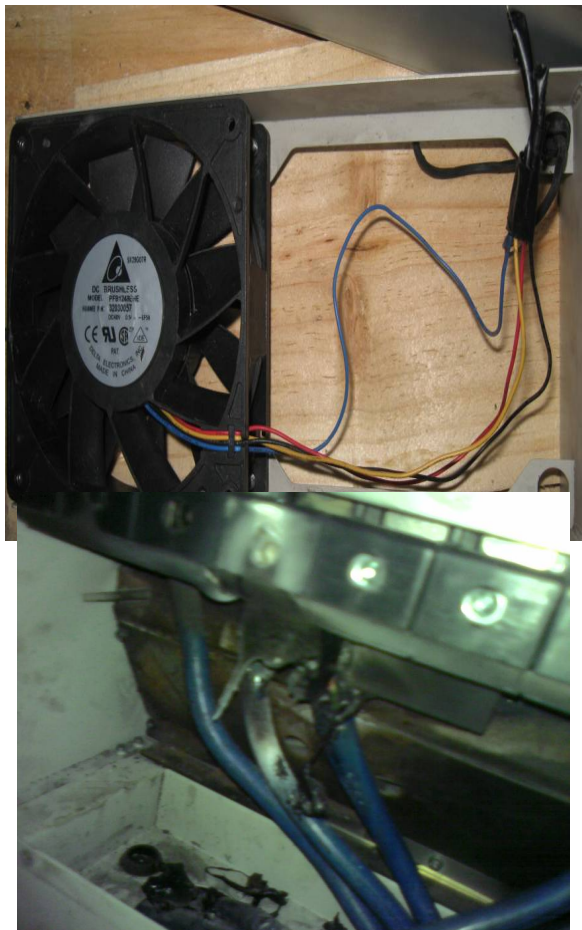
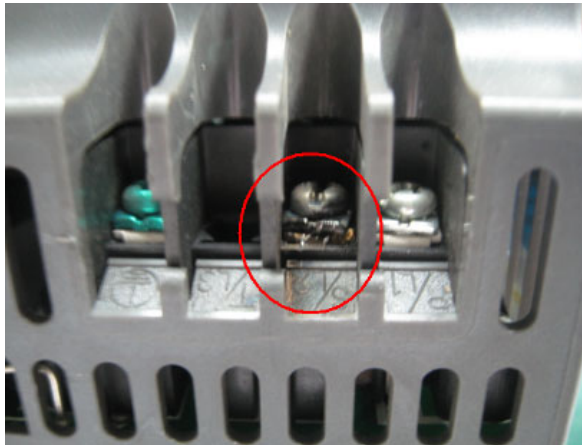

6-7 Multi-function Input/Output Terminals Problem

Multi-function input/output terminal errors are generally caused by over usage of terminals and not following specifications. Please be aware of the possible damages that errors on multi-function input/output terminals may cause to your drives:

1. Input/output circuit may burn out when the terminal usage exceeds its limit.

Solution:

Refer to the user manual for multi-function input output terminals usage and follow the specified voltage and current. DO NOT exceed the specification limits.

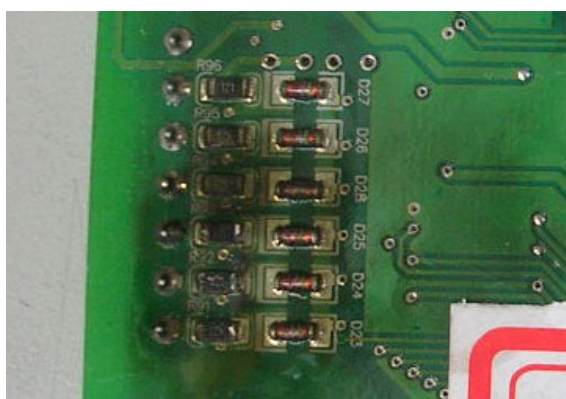
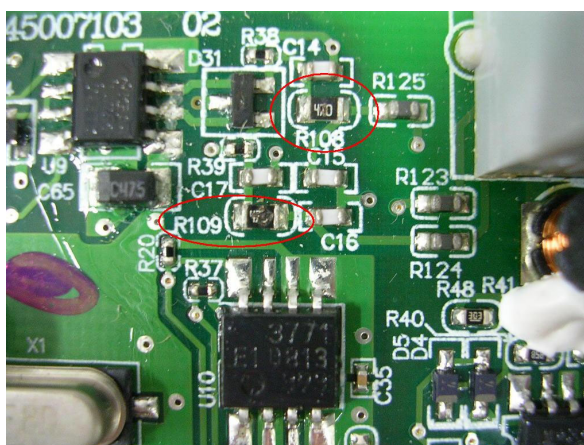
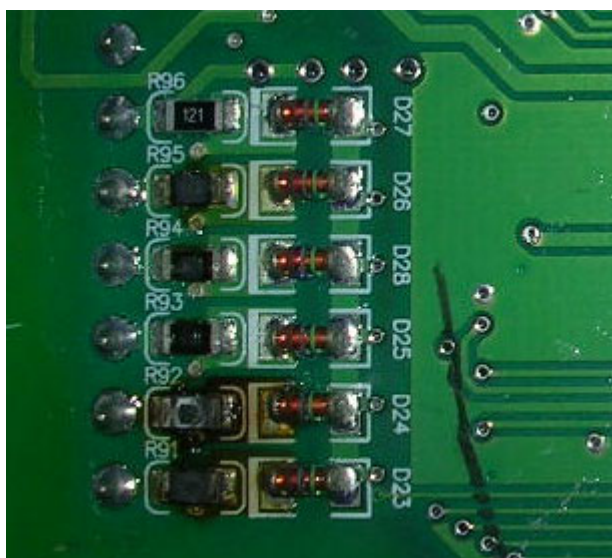

6-8 Maintenance of Coupling

It is recommended that you visually check the condition of the coupling at least once a year, and pay special attention to the condition of the wye junction on the couplings.

Since the passive bearing and the active bearing of the mechanical bearings goes up and down while the hybrid servo controller runs, verify if the couplings are aligned and realign the couplings if necessary.

Verify the parts of the couplings periodically such as if the metal parts on both sides and the middle plastic sleeve are deformed or damaged. Also visually verify if the screws are loose.

Appendix A: Optional Accessories

- A-1 Non-fuse Circuit Breaker
- A-2 Reactor
- A-3 Digital Keypad KPC-CC01
- A-4 EMI Filter
- A-5 Speed Feedback Encoder



- This hybrid servo controller has gone through rigorous quality control tests at the factory before shipment. If the package is damaged during shipping, please contact your dealer.
 - The accessories produced by Delta are only for using with Delta hybrid servo controller. Do NOT use with other controller to prevent damage.
-

A-1 Non-Fuse Circuit Breaker

VJ-C series:

Comply with the UL standard: Per UL 61800-5-12

The rated current of the breaker shall be 2 - 4 times of the maximum rated input current of hybrid servo controller.

Air Cooled:

Model	Recommended Current (A)
VFD300VL23C-J	250
VFD370VL23C-J	300
VFD110VL43C-J	50
VFD150VL43C-J	60
VFD185VL43C-J	80
VFD220VL43C-J	100
VFD300VL43C-J	125
VFD370VL43C-J	150
VFD450VL43C-J	200
VFD550VL43C-J	225
VFD750VL43C-J	300

A-2 Reactor

Installing an AC reactor on the input side of a hybrid servo controller can increase line impedance, improve the power factor, reduce input current, and reduce interference generated from the hybrid servo controller. It also reduces momentary voltage surges or abnormal current spikes. For example, when the main power capacity is higher than 500 kVA, or when using a switching capacitor bank, momentary voltage and current spikes may damage the hybrid servo controller's internal circuit. An AC reactor on the input side of the hybrid servo controller protects it by suppressing surges.

Installation:

As shown in the image below, an AC input reactor is installed between the mains power inputs and the R S T input terminals on the hybrid servo controller.

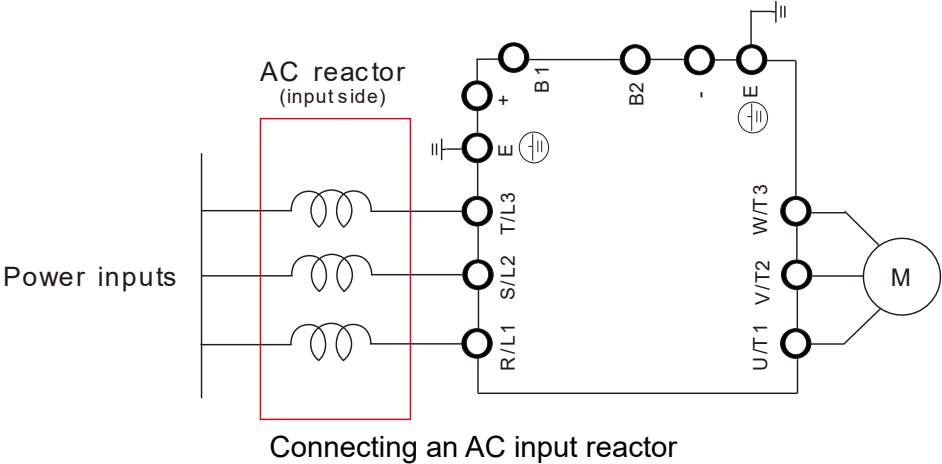

A-2-1 AC Reactor
Specifications: AC Input Reactor

Air Cooled:

200V~230V/ 50~60Hz model VFDXXXVL23C-J series AC Input Reactor							
Model	KW	HP	Rated Current (Arms)	Saturation Current (Arms)	3% Reactor (mH)	5% Reactor (mH)	3% Input Reactor: Delta Part #
300	30	40	120	240	0.12	0.2	DR105AP106
370	37	50	146	292	0.087	0.145	DR146AP087

380V~460V/ 50~60Hz model VFDXXXVL43C-J series AC Input Reactor							
Model	KW	HP	Rated Current (Arms)	Saturation Current (Arms)	3% Reactor (mH)	5% Reactor (mH)	3% Input Reactor: Delta Part#
110	11	15	21	42	1.01	1.683	DR024AP881
150	15	20	27	54	0.76	1.267	DR032AP660
185	18.5	25	34	68	0.639	1.066	DR038AP639
220	22	30	41	82	0.541	0.9	DR045AP541
300	30	40	60	120	0.405	0.675	DR060AP405
370	37	50	73	146	0.334	0.555	DR073AP334
450	45	60	91	182	0.267	0.445	DR091AP267
550	55	75	110	220	0.221	0.368	DR110AP221
750	75	100	150	300	0.162	0.27	DR150AP162

Specifications: AC Output Reactor

230V, 50/60Hz, Three-Phase

kW	HP	Rated Current of Reactor	Maximum Continuous Current	Inductance (mH)	
				3% Impedance	5% Impedance
30	40	130	195	0.1	0.2
37	50	160	240	0.075	0.15

460V, 50/60Hz, Three-Phase

kW	HP	Rated Current of Reactor	Maximum Continuous Current	Inductance (mH)	
				3% Impedance	5% Impedance
15	20	35	52.5	0.8	1.2
18.5	25	45	67.5	0.7	1.2
22	30	45	67.5	0.7	1.2
30	40	80	120	0.4	0.7
37	50	80	120	0.4	0.7
45	60	100	150	0.3	0.45
55	75	130	195	0.2	0.3
75	100	160	240	0.15	0.23

Application of AC Reactor

Connected in input circuit

Application 1

When more than one hybrid controller / drive is connected to the same mains power and one of them is ON during operation.

Problem: When applying power to one of the hybrid controller / drive, the charge current of the capacitors may cause voltage dip. The hybrid controller / drive may be damaged when over current occurs during operation.

Correct wiring:

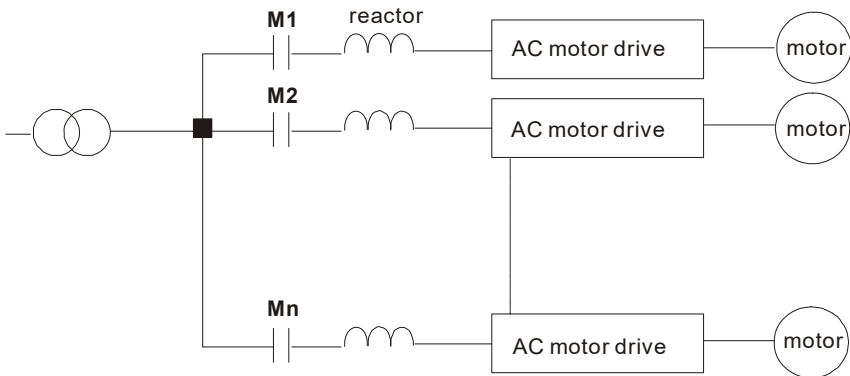

Application 2

Silicon rectifier and hybrid controller / drive are connected to the same power.

Problem: Switching spikes will be generated when the silicon rectifier switches ON/OFF. These spikes may damage the mains circuit.

Correct wiring:

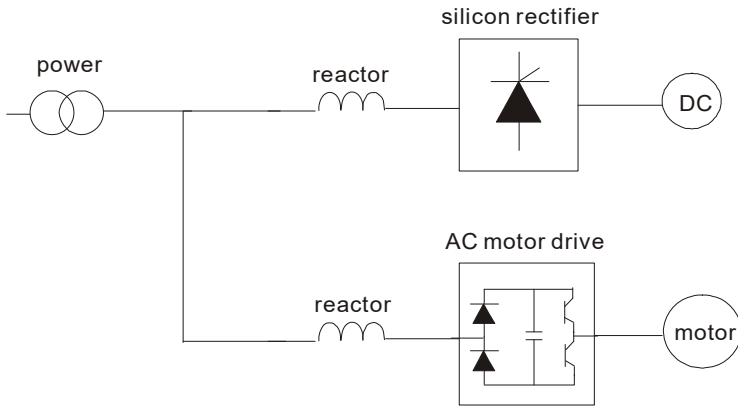

Application 3

When the power supply capacity exceeds 10 times of the inverter capacity.

Problem: When the mains power capacity is too large, line impedance will be small and the charge current will be too high. This may damage hybrid controller / drive due to higher rectifier temperature.

Correct wiring:



A-3 Digital Keypad KPC-CC01

The HES series products use the digital keypad KPC-CC01 as the display unit. For the actual keypad appearance, please refer to the actual product. This picture shows the schematic diagram for illustrative purposes only.

KPC-CC01 Digital Keypad:

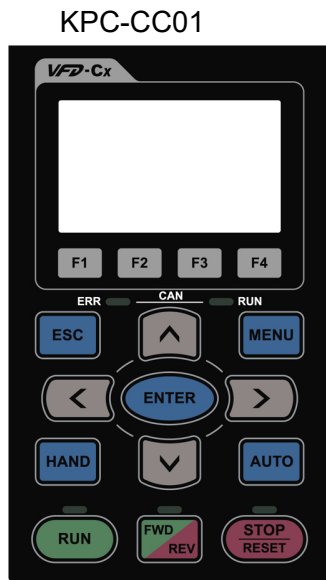



Communication Interface
 RJ-45 (socket) , RS-485(Interface)

Installation

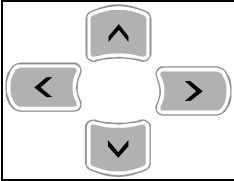
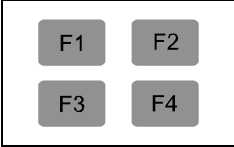

- ☑ **Embedded type and can be put flat on the surface of the control box. The front cover is waterproof.**
- ☑ **Buy a MKC-KPPK model to do wall mounting or embedded mounting. Its protection level is IP66.**
- ☑ **The maximum RJ45 extension lead is 5 m (16ft)**

Descriptions of Keypad Functions

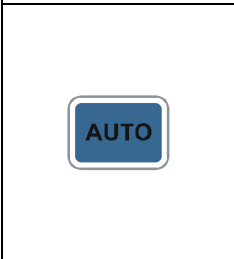
Key	Descriptions
	Start Operation Key 1. It is only valid when the source of operation command is from the keypad. 2. It can operate the hybrid servo controller by the function setting and the RUN LED will be on. 3. It can be pressed repeatedly during stop. 4. When enabling "HAND" mode, it is only valid when the source of operation command is from the keypad.
	Stop Command Key. This key has the highest processing priority in any situation. 1. When it receives STOP command, no matter the hybrid servo controller is in operation or stop status, the hybrid servo controller needs to execute "STOP" command. 2. The RESET key can be used to reset the controller / drive after the fault occurs. For those faults that cannot be reset by the RESET key, see the fault records after pressing MENU key for details.
	Operation Direction Key 1. This key is only control the operation direction NOT for activate the controller / drive. FWD: forward, REV: reverse. 2. Refer to the LED descriptions for more details.
	ENTER Key Press ENTER and go to the next level. If it is the last level then press ENTER to execute the command.
	ESC Key ESC key function is to leave current menu and return to the last menu. It is also functioned as a return key in the sub-menu.
	Press menu to return to main menu.

	<p>Direction: Left/Right/Up/Down</p> <ol style="list-style-type: none"> In the numeric value setting mode, it is to move the cursor and change the numeric value. In the menu/text selection mode, it is for item selection.
	<p>Function Key</p> <ol style="list-style-type: none"> The functions keys have factory settings and can be defined by users. Other functions must be defined by TPEditor first.
	<p>HAND Key</p> <ol style="list-style-type: none"> This key is controlled by the parameter settings of the source of Hand frequency and hand operation. The factory settings of both source of Hand frequency and hand operation are the digital keypad. Press HAND key at stop, the setting will switch to hand frequency source and hand operation source. Press HAND key when the hybrid servo controller is running, it stops the hybrid servo controller first (display AHSP warning), and switch to hand frequency source and hand operation source.
	<ol style="list-style-type: none"> This key is controlled by the parameter settings of the source of AUTO frequency and AUTO operation. The factory setting is the external terminal (source of operation is 4-20mA). Press Auto key at stop, the setting will switch to hand frequency source and hand operation source. Press Auto key when the hybrid servo controller is running, it stops the hybrid servo controller first (display AHSP warning), and switch to auto frequency source and auto operation source.

Descriptions of LED Functions

LED	Descriptions
	<p>Steady ON: operation indicator of the hybrid servo controller, including DC brake, zero speed, standby, restart after fault and speed search. Blinking: controller / drive is decelerating to stop or in the status of base block. Steady OFF: controller / drive doesn't execute the operation command</p>
	<p>Steady ON: stop indicator of the hybrid servo controller. Blinking: controller / drive is in the standby status. Steady OFF: controller / drive does not execute "STOP" command.</p>
	<p>Operation Direction LED</p> <ol style="list-style-type: none"> Green light is on, the controller / drive is running forward. Red light is on, the controller / drive is running backward. Twinkling light: the controller / drive is changing direction.

Characters of Digital Keypad Displayed on the LCD

Number	0	1	2	3	4	5	6	7	8	9
LCD	0	1	2	3	4	5	6	7	8	9
Alphabet	A	b	Cc	d	E	F	G	Hh	I	Jj
LCD	A	b	Cc	d	E	F	G	Hh	I	Jj
Alphabet	K	L	n	Oo	P	q	r	S	Tt	U
LCD	K	L	n	Oo	P	q	r	S	Tt	U
Alphabet	v	Y	Z							
LCD	v	Y	Z							

A-4 EMI Filter

VJ-C Air Cooled Models::

Controller	Applicable Filter Model #	Reference Website
VFD110VL43C-J	B84143A0050R106	Power Line EMC Filter (EPCOS)
VFD150VL43C-J		
VFD185VL43C-J		
VFD220VL43C-J		
VFD300VL43C-J	B84143A0100R106	
VFD370VL43C-J		
VFD450VL43C-J	B84143D0200R127	
VFD550VL43C-J		
VFD750VL43C-J		
VFD300VL23C-J		
VFD370VL23C-J		

<https://www.tdk-electronics.tdk.com/en/530116/products/product-catalog/emc-components/power-line-emc-filters--epcos->

EMI Filter Installation

All electrical equipment, including hybrid controller / drive, will generate high-frequency/low-frequency noise and will interfere with peripheral equipment by radiation or conduction when in operation. By using an EMI filter with correct installation, much interference can be eliminated. It is recommended to use DELTA EMI filter to have the best interference elimination performance.

We assure that it can comply with following rules when hybrid controller / drive and EMI filter are installed and wired according to user manual:

- **EN61000-6-4**
- **EN61800-3: 1996**
- **EN55011 (1991) Class A Group 1 (1st Environment, restricted distribution)**

General precaution

1. EMI filter and hybrid controller / drive should be installed on the same metal plate.
2. Please install hybrid controller / drive on footprint EMI filter or install EMI filter as close as possible to the hybrid controller / drive.
3. Please wire as short as possible.
4. Metal plate should be grounded.
5. The cover of EMI filter and hybrid controller / drive or grounding should be fixed on the metal plate and the contact area should be as large as possible.

Choose suitable motor cable and precautions

Improper installation and choice of motor cable will affect the performance of EMI filter. Be sure to observe the following precautions when selecting motor cable.

1. Use the cable with shielding (double shielding is the best).
2. The shielding on both ends of the motor cable should be grounded with the minimum length and maximum contact area.
3. Remove any paint on metal saddle for good ground contact with the plate and shielding.

Remove any paint on metal saddle for good ground contact with the plate and shielding.

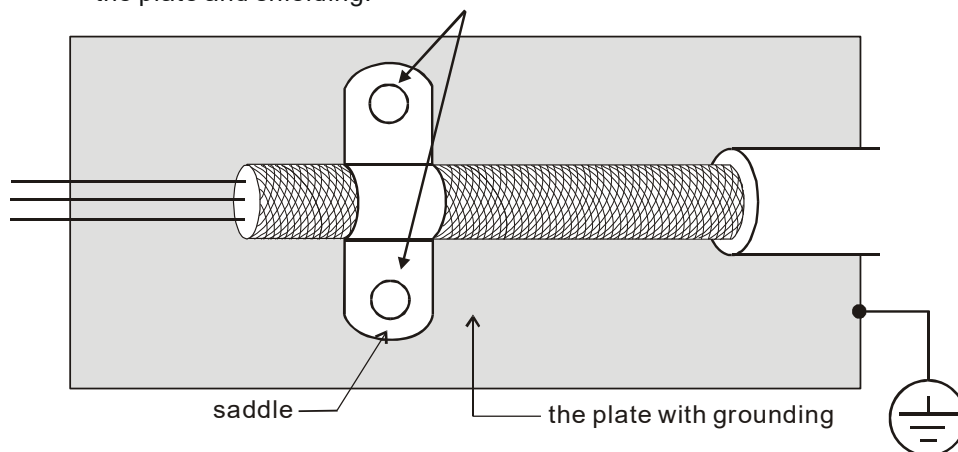
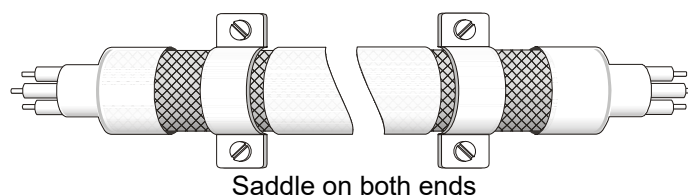

Figure 1



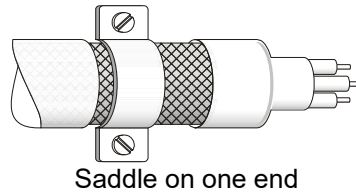

Figure 2

The length of motor cable

When motor is driven by a hybrid controller / drive of PWM type, the motor terminals will experience surge voltages easily due to components conversion of hybrid controller / drive and cable capacitance. When the motor cable is very long (especially for the 460V models), surge voltages may reduce insulation quality. To prevent this situation, please follow the rules below:

- Use a motor with enhanced insulation.
- Connect an output reactor (optional) to the output terminals of the hybrid controller / drive
- The length of the cable between hybrid controller / drive and motor should be as short as possible (10 to 20 m or less)
- For models 7.5hp and above:

Insulation level of motor	1000V	1300V	1600V
460V _{AC} input voltage	66 ft (20m)	328 ft (100m)	1312 ft (400m)
230V _{AC} input voltage	1312 ft (400m)	1312 ft (400m)	1312 ft (400m)

 **NOTE**

Never connect phase lead capacitors or surge absorbers to the output terminals of the hybrid controller / drive.

- If the length is too long, the stray capacitance between cables will increase and may cause leakage current. It will activate the protection of over current, increase leakage current or not insure the correction of current display. The worst case is that hybrid controller / drive may be damaged.
- If more than one motor is connected to the hybrid controller / drive, the total wiring length is the sum of the wiring length from hybrid controller / drive to each motor.
- For the 460V models hybrid controller / drive, when an overload relay is installed between the hybrid controller / drive and the motor to protect motor from overheating, the connecting cable must be shorter than 50m. However, an overload relay malfunction may still occur. To prevent the malfunction, install an output reactor (optional) to the hybrid controller / drive or lower the carrier frequency setting (Pr.00-17).

 **NOTE**

When a thermal O/L relay protected by motor is used between hybrid controller / drive and motor, it may malfunction (especially for 460V models), even if the length of motor cable is only 165ft (50m) or less. To prevent it, please use AC reactor and/or lower the carrier frequency (Pr.00-17 PWM carrier frequency).

A-5 Speed Feedback Encoder

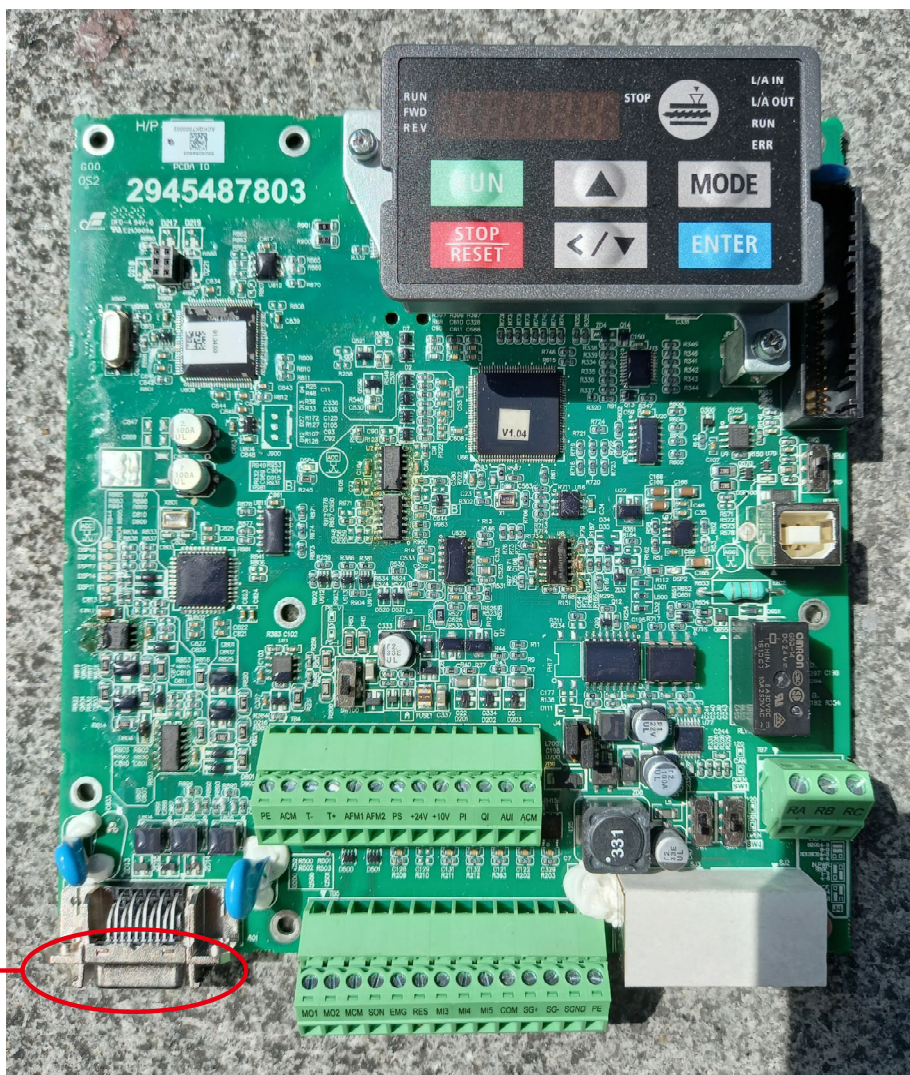

Encoder
connector

Function of J1 Terminal

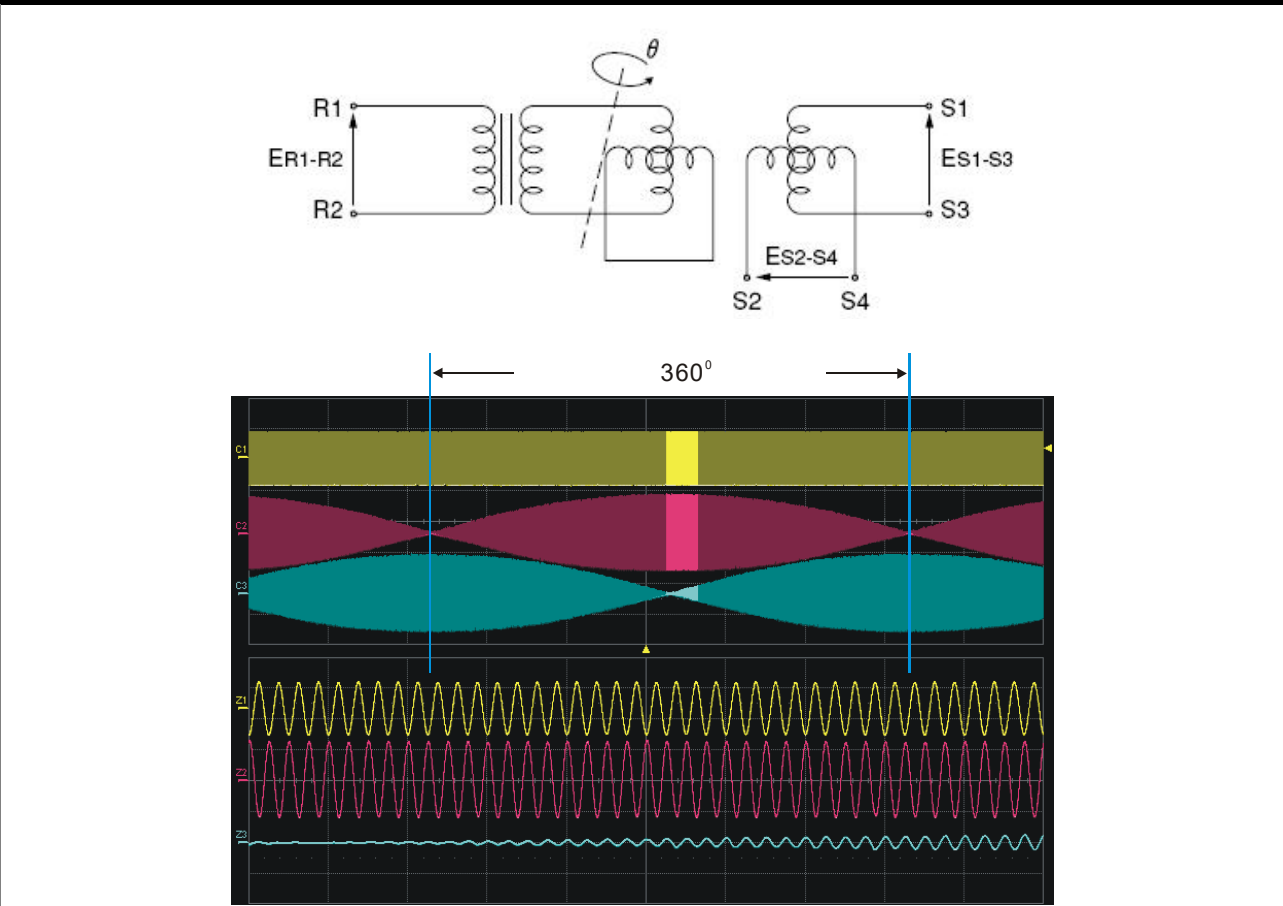

As shown in the image above, from top to bottom: C1 『ER1-R2』, C2 『ES1-S3』, C3 『ES2-S4』

Pin #	Terminal	Function	Specification
4	SIN- (S4)	Resolver output signal	3.5±0.175Vrms, 10kHz
5	SIN+ (S2)		
7	COS+ (S1)		
9	COS- (S3)		
14,16	REF+ (R1)	Resolver input power	7Vrms, 10kHz
13,15	REF- (R2)		
	blocked	Blocked	

Selection of Wiring Rod

Encoder Wiring — Wire Gauge mm ² (AWG)			
Size	# of cores (pairs)	Specification	Standard Length
0.13 mm ² (AWG26)	10 cores(4 pairs)	UL2464	3m (9.84 ft)

NOTE

- 1) Please use shielded twisted-pair cable for encoder wiring so as to reduce the interference of the noise.
- 2) The shield should connect to the ⊕ phase of SHIELD.
- 3) Please follow the Selection of Wire Rod when wiring in order to avoid the danger it may occur.

Connector Specification

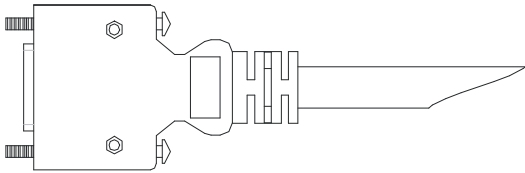

Title	Part #	Manufacturer
PLUG	3M 10120-3000PE	3M
SHELL	3M 10320-52A0-008	3M

Appendix B: CANopen Overview

- B-1** CANopen Overview
- B-2** Wiring for CANopen
- B-3** CANopen Communication Interface Description
- B-4** CANopen Supporting Index
- B-5** CANopen LED Light Indicator

The built-in CANopen function is a kind of remote control. You can control the AC motor drive using the CANopen protocol. CANopen is a CAN-based higher layer protocol that provides standardized communication objects, including real-time data (Process Data Objects, PDO), configuration data (Service Data Objects, SDO), and special functions (Time Stamp, Sync message, and Emergency message). It also has network management data, including Boot-up message, NMT message, and Error Control message. Refer to the CiA website <http://www.can-cia.org/> for details. The content of this instruction sheet may be revised without prior notice. Consult our distributors or download the most updated version at <http://www.delta.com.tw/industrialautomation>

Delta CANopen supported functions:

- Supports CAN2.0A Protocol
- Supports CANopen DS301 V4.02
- Supports DSP-402 V2.0

Delta CANopen supported services:

- PDO (Process Data Objects): PDO1–PDO4
- SDO (Service Data Object):
 - Initiate SDO Download;
 - Initiate SDO Upload;
 - Abort SDO;
 - You can use the SDO message to configure the slave node and access the Object Dictionary in every node.
- SOP (Special Object Protocol):
 - Supports default COB-ID in Predefined Master/Slave Connection Set in DS301 V4.02;
 - Supports SYNC service;
 - Supports Emergency service.
- NMT (Network Management):
 - Supports NMT module control;
 - Supports NMT Error control;
 - Supports Boot-up.

Delta CANopen does not support this service:

- Time Stamp service

B-1 CANopen Overview

• CANopen Protocol

CANopen is a CAN-based higher layer protocol, and was designed for motion-oriented machine control networks such as handling systems. Version 4.02 of CANopen (CiA DS301) is standardized as EN50325-4. The CANopen specifications cover the application layer and communication profile (CiA DS301), as well as a framework for programmable devices (CiA 302), recommendations for cables and connectors (CiA 303-1) and SI units and prefix representations (CiA 303-2).

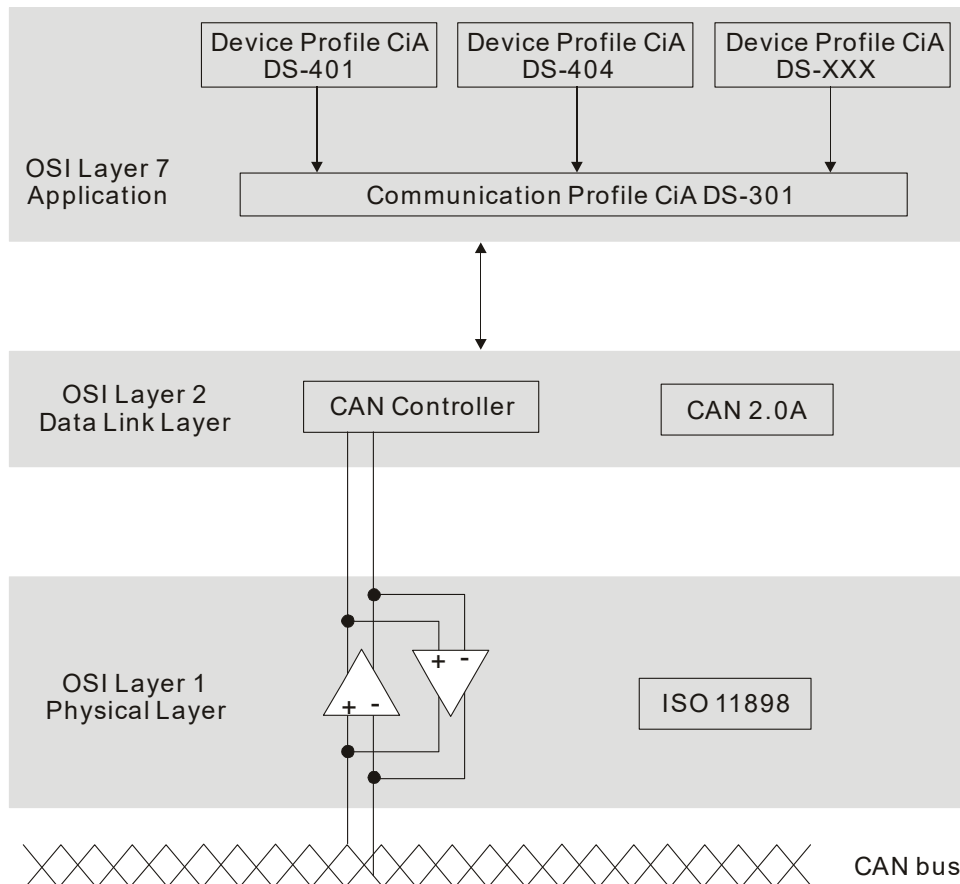

RJ-45 Pin Definition

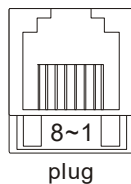

PIN	Signal	Description
1	CAN_H	CAN_H bus line (dominant high)
2	CAN_L	CAN_L bus line (dominant low)
3	CAN_GND	Ground / 0 V /V-
6	CAN_GND	Ground / 0 V /V-

CANopen Communication Protocol contains the following services:

- NMT (Network Management Object)
- SDO (Service Data Objects)
- PDO (Process Data Object)
- EMCY (Emergency Object)

NMT (Network Management Object)

The Network Management (NMT) follows a Master/Slave structure for executing NMT service. A network has only one NMT master, and the other nodes are slaves. All CANopen nodes have a present NMT state, and the NMT master can control the state of the slave nodes. The following shows the state diagram of a node:

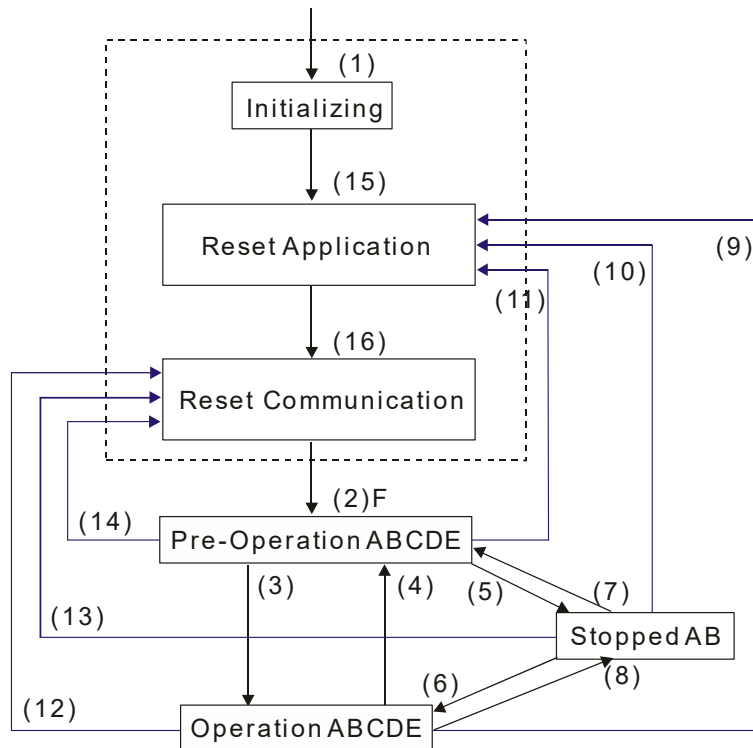

- (1) After power is applied, start in the auto-initialization state
 - (2) Automatically enter the pre-operational state
 - (3) (6) Start remote node
 - (4) (7) Enter the pre-operational state
 - (5) (8) Stop remote node
 - (9) (10) (11) Reset node
 - (12) (13) (14) Reset communication
 - (15) Automatically enter reset application state
 - (16) Automatically enter reset communication state
- A: NMT
 - B: Node Guard
 - C: SDO
 - D: Emergency
 - E: PDO
 - F: Boot-up

	Initializing	Pre-Operational	Operational	Stopped
PDO			○	
SDO		○	○	
SYNC		○	○	
Time Stamp		○	○	
EMCY		○	○	
Boot-up	○			
NMT		○	○	○

SDO (Service Data Objects)

Use SDO to access the Object Dictionary in every CANopen node using the Client/Server model. One SDO has two COB-IDs (request SDO and response SDO) to upload or download data between two nodes. There is no data limit for SDOs to transfer data, but it must transfer data by segment when the data exceeds four bytes with an end signal in the last segment. The VJ series does not currently support segment transmission.

The Object Dictionary (OD) is a group of objects in a CANopen node. Every node has an OD in the system, and OD contains all parameters describing the device and its network behavior. The access path in the OD is the index and sub-index; each object has a unique index in the OD, and has a sub-index if necessary. The following shows the request and response frame structure of SDO communication:

PDO (Process Data Object)

PDO communication can be described by the producer/consumer model. Each node of the network listens to the messages of the transmission node and distinguishes whether the message has to be processed or not after receiving the message. A PDO can be transmitted from one device to one another device or to many other devices. Every PDO has two PDO services: a TxPDO and an RxPDO. PDOs are transmitted in a non-confirmed mode. All transmission types are listed in the following table:

Type Number	PDO				
	Cyclic	Acyclic	Synchronous	Asynchronous	RTR only
0		○	○		
1-240	○		○		
241-251	Reserved				
252			○		○
253				○	○
254				○	
255				○	

Type number 0 indicates the synchronous aperiodic message between two PDO transmissions.

Type number 1-240 indicates the number of SYNC message between two PDO transmissions.

Type number 252 indicates the data is updated (but not sent) immediately after receiving SYNC.

Type number 253 indicates the data is updated immediately after receiving RTR.

Type number 254: Delta CANopen doesn't support this transmission format.

Type number 255 indicates the data is an asynchronous aperiodic transmission.

All PDO transmission data must be mapped to the index with Object Dictionary.

EMCY (Emergency Object)

When errors occur inside the hardware, an emergency object is triggered. An emergency object is only sent when an error occurs. As long as there is nothing wrong with the hardware, there is no emergency object warning of an error message.

B-2 Wiring for CANopen

The wiring between CANopen and VJ doesn't require any external communication card. Use an RJ45 cable to connect CANopen to a VJ. You must terminate the two farthest ends with 120Ω terminating resistors as shown in the picture below.

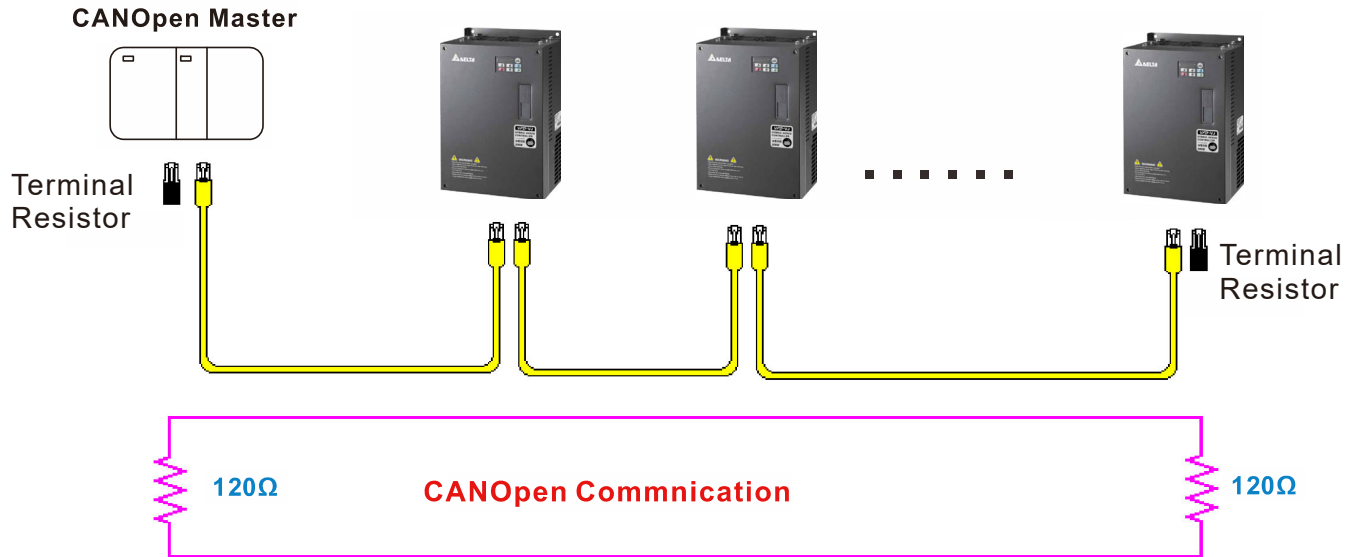

B-3 CANopen Communication Interface Descriptions

B-3-1 CANopen Control Mode Selection

There are two control modes for CANopen: the DS402 standard (Pr.04-20 set to 1) is the factory setting, and the Delta's standard setting (Pr.04-20 set to 0). There are two control modes according to Delta's standard. One is the old control mode (Pr.04-24=0); this control mode can only control the motor drive under frequency control. The other mode is a new standard (Pr.04-24=1); this new control mode allows the motor drive to be controlled under multiple modes. The VJ currently supports speed mode. The following table shows the control mode definitions:

CANopen control mode	Control mode	
	Speed	
	Index	Description
DS402 Pr.04-20=1	6042-00	Target rotating speed (RPM)
	-----	-----
Delta Standard (Old definition) Pr.04-20=0, Pr.04-24=0	2020-02	Target rotating speed (Hz)
Delta Standard (New definition) Pr.04-20=0, Pr.04-24=1	2060-03	Target rotating speed (Hz)
	2060-04	Torque limit (%)

CANopen control mode	Operation control	
	Index	Description
DS402 Pr.04-20=1	6040-00	Operation Command
	-----	-----
Delta Standard (Old definition) Pr.04-20=0, Pr.04-24=0	2020-01	Operation Command
Delta Standard (New definition) Pr.04-20=0, Pr.04-24=1	2060-01	Operation Command
	-----	-----

CANopen control mode	Other	
	Index	Description
DS402 Pr.04-20=1	605A-00	Quick stop processing mode
	605C-00	Disable operation processing mode
Delta Standard (Old definition) Pr.04-20=0, Pr.04-24=0	-----	-----
Delta Standard (New definition) Pr.04-20=0, Pr.04-24=1	-----	-----
	-----	-----

You can use some indices in either DS402 or Delta's standard. For example:

1. Indices that are defined as RO attributes
2. The corresponding index of available parameter groups: (2000-00–200E-XX)
3. Accelerating/Decelerating Index: 604F 6050

B-3-2 DS402 Standard Control Mode

B-3-2-1 Related set up for an AC motor drive (following the DS402 standard)

If you want to use the DS402 standard to control the motor drive, follow these steps:

1. Wire the hardware (refer to chapter B-2 Wiring for CANopen).
2. Set the operation source: set Pr.01-01 to 3 for CANopen communication card control.
3. Set the frequency source: set Pr.03-15 to 6. Choose the source for the Frequency command from the CANopen setting.
4. Set DS402 for the control mode: Pr.04-20=1
5. Set the CANopen station: set the CANopen station (range 1-127, 0 is the disable CANopen slave function) with Pr.04-17. Note: set Pr.00-02 = 7 to reset if the station number error CAde or CANopen memory error CFrE appears.
6. Set the CANopen baud rate: set Pr.04-18 (CANBUS Baud Rate: 1M (0), 500K (1), 250K (2), 125K (3), 100K (4) or 50K (5)).

B-3-2-2 The status of the motor drive (by following DS402 standard)

According to the DS402 definition, the motor drive is divided into 3 blocks and 9 statuses as described below.

3 blocks

1. Power Disable: without PWM output
2. Power Enable: with PWM output
3. Fault: one or more errors have occurred.

9 status

1. Start: power on
2. Not Ready to Switch On: the motor drive is initiating.
3. Switch On Disable: occurs when the motor drive finishes initiating.
4. Ready to Switch On: warming up before running.
5. Switch On: the motor drive has the PWM output, but the reference command is not effective.
6. Operate Enable: able to control normally.
7. Quick Stop Active: when there is a Quick Stop request, stop running the motor drive.
8. Fault Reaction Active: the motor drive detects conditions which might trigger error(s).
9. Fault: one or more errors have occurred in the motor drive.

When the motor drive is turned on and finishes the initiation, it remains in Ready to Switch On status. To control the operation of the motor drive, change to Operate Enable status. To do this, set the control word's bit0–bit3 and bit7 of the Index 6040H and pair with Index Status Word (Status Word 0X6041). The control steps and index definition are described below:

Index 6040

15–9	8	7	6–4	3	2	1	0
Reserved	Halt	Fault Reset	Operation	Enable operation	Quick Stop	Enable Voltage	Switch On

Index 6041

15–14	13–12	11	10	9	8	7	6	5	4	3	2	1	0
Reserved	Operation	Internal limit active	Target reached	Remote	Reserved	Warning	Switch on disabled	Quick stop	Voltage enabled	Fault	Operation enable	Switch on	Ready to switch on

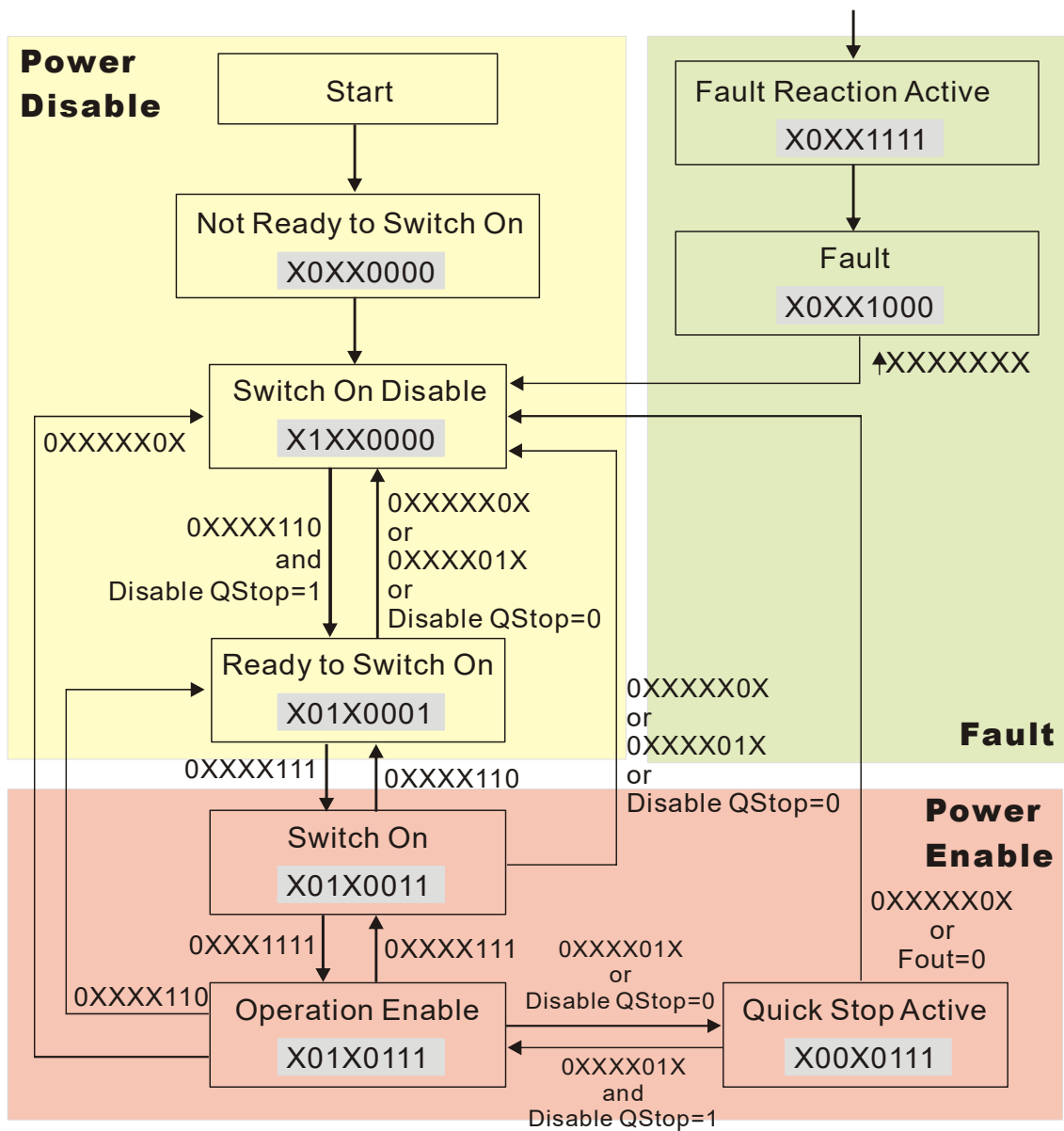

Set command 6040=0xE, then set another command 6040=0xF. Then you can switch the motor drive to Operation Enable. The Index 605A determines the direction of the lines from Operation Enable when the control mode changes from Quick Stop Active. When the setting value is 5–7, both lines are active, but when the setting value of 605A is not 5–7, once the motor drive is switched to Quick Stop Active, it is not able to switch back to Operation Enable.

Index	Sub	Definition	Factory Setting	R/W	Size	Unit	PDO Map	Mode	note
605Ah	0	Quick stop option code	2	RW	S16		No		0: Disable drive function
									1: Slow down on slow down ramp
									2: Slow down on quick stop ramp
									5: Slow down on slow down ramp and stay in Quick Stop
									6: Slow down on quick stop ramp and stay in Quick Stop
7: Slow down on the current limit and stay in Quick Stop									

When the control section switches from Power Enable to Power Disable, use 605C to define the parking method.

Index	Sub	Definition	Factory Setting	R/W	Size	Unit	PDO Map	Mode	note
605Ch	0	Disable operation option code	1	RW	S16		No		0: Disable drive function 1: Slow down with slow down ramp; disable the drive function

B-3-2-3 Various mode control method (by following DS402 standard)

Speed mode

1. Set VJ to speed control mode: set Index6060 to 2.
2. Switch to Operation Enable mode: set 6040=0xE, then set 6040=0xF.
3. Set the target frequency: set target frequency for 6042, since the operation unit of 6042 is rpm, a transform is required:

$$n = f \times \frac{120}{p}$$

n: rotation speed (rpm) (rounds/minute) p: number of poles in the motor
(Pole)
f: rotation frequency (Hz)

For example:

Set 6042H = 1500 (rpm), if the number of poles is 4 (Pr.05-04 or Pr.05-16), then the motor drive's operation frequency is 1500 (120/4) = 50 Hz. The 6042 is defined as a signed operation. The plus or minus sign means to rotate clockwise or counter-clockwise.

4. To set acceleration and deceleration: use 604F (Acceleration) and 6050 (Deceleration).
5. Trigger an ACK signal: in the speed control mode, the bit 6–4 of Index 6040 needs to be controlled. It is defined below:

Speed mode (Index 6060=2)	Index 6040			SUM
	Bit 6	Bit 5	Bit 4	
	1	0	1	Locked at the current signal.
	1	1	1	Run to reach targeting signal.
	Other			Decelerate to 0 Hz.

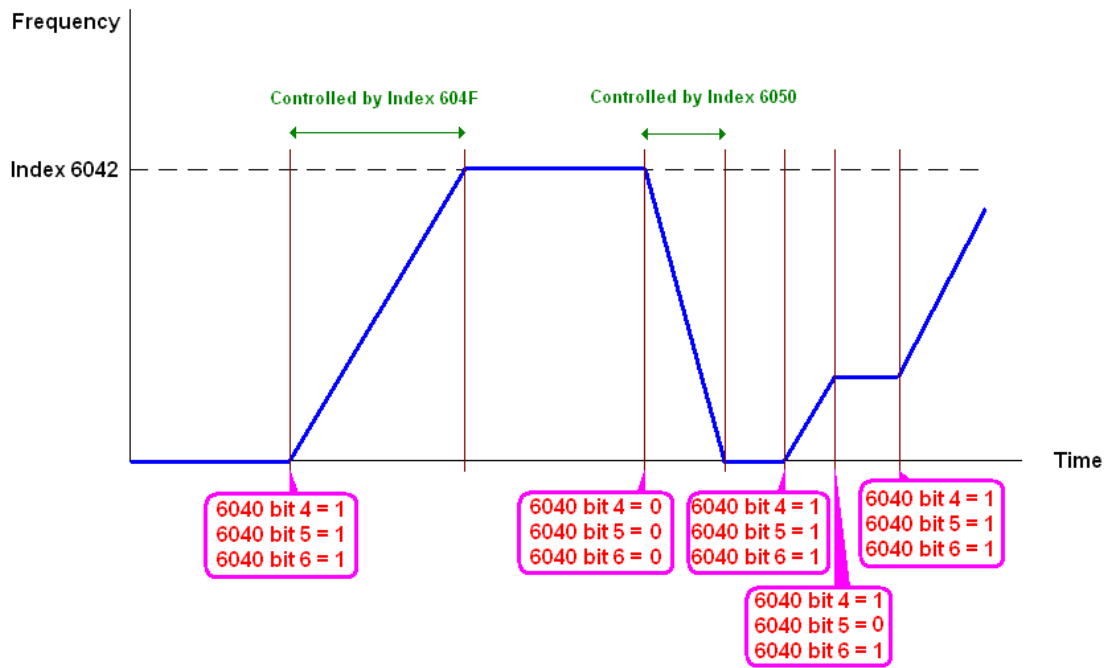

NOTE 01: Read 6043 to get the current rotation speed (unit: rpm).

NOTE 02: Read bit 10 of 6041 to find if the rotation speed has reached the targeting value (0: Not reached; 1: Reached).

B-3-3 Using Delta Standard (Old definition)

B-3-3-1 Various mode control method (Delta Old Standard).

Follow the steps below:

1. Wire the hardware (refer to Section B-2 Wiring for CANopen).
2. Set the operation source: set Pr.01-01 to 3 for CANopen communication card control.
3. Set the frequency source: set Pr.03-15 to 6. Choose the source for the Frequency command from the CANopen setting.
4. Set Delta Standard (Old definition, only supports speed mode) as the control mode: Pr.04-20 = 0 and Pr.04-24 = 0.
5. Set the CANopen station: set Pr.09-36; the range is between 1–127. When Pr.09-36=0, the CANopen slave function is disabled. Note: if an error appears (CAeE or CANopen memory error) as you complete the station setting, set Pr.00-02=10 to reset.
6. Set the CANopen baud rate: set Pr.04-18 (CANBUS Baud Rate: 1M (0), 500K (1), 250K (2), 125K (3), 100K (4) and 50K (5))

B-3-3-2 By speed mode

1. Set the target frequency: set 2020-02, the unit is Hz, with 2 decimal places. For example 1000 is 10.00 Hz.
2. Operation control: set 2020-01 = 0002H for running, and set 2020-01 = 0001H for stopping.

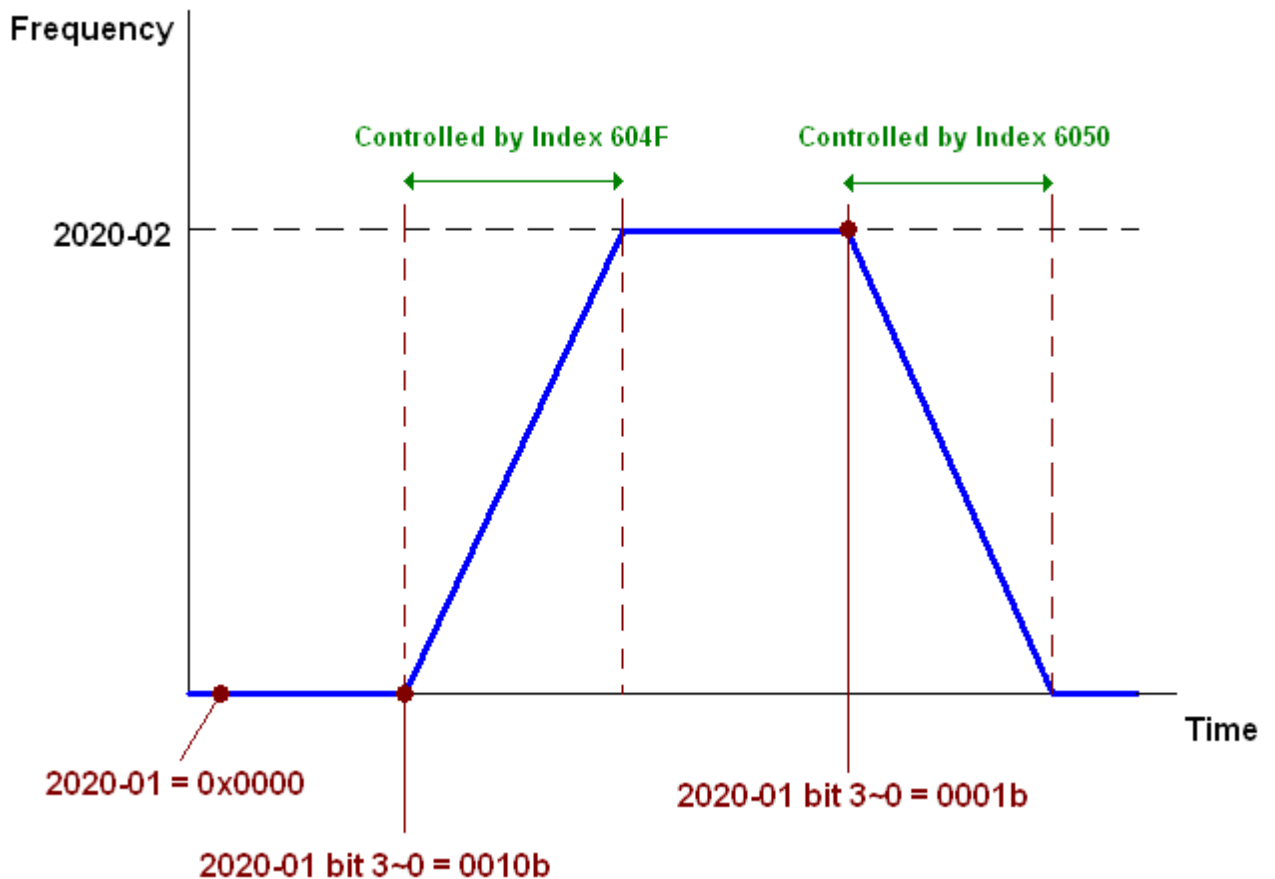

B-3-4 Using Delta Standard (New definition)

B-3-4-1 Related set up for an AC motor drive (Delta New Standard)

Follow the steps below:

1. Wire the hardware (refer to Section B-2 Wiring for CANopen).
2. Set the operation source: set Pr.01-01 to 3 for CANopen communication card control.
3. Set the frequency source: set Pr.03-15 to 6. Choose the source for the Frequency command from the CANopen setting.
4. Set Delta Standard (New definition) as the control mode: Pr.04-20 = 0 and 04-24 = 1.
5. Set the CANopen station: set Pr.04-17; the range is between 1–127. When Pr.04-17=0, the CANopen slave function is disabled. Note: if an error appears (CA_dE or CANopen memory error) as you complete the station setting, set Pr.00-02=10 to reset.
6. Set the CANopen baud rate: set Pr.04-18 (CANBUS Baud Rate: 1M (0), 500K (1), 250K (2), 125K (3), 100K (4) and 50K (5))

B-3-4-2 Various mode control method (Delta New Standard)

Speed Mode

1. Set VJ to speed control mode: set index 6060 = 2.
2. Set the target frequency: set 2060-03, unit is Hz, with 2 decimal places. For example 1000 is 10.00 Hz.
3. Operation control: set 2060-01 = 0080H for server on, and set 2060-01 = 0081H for running.

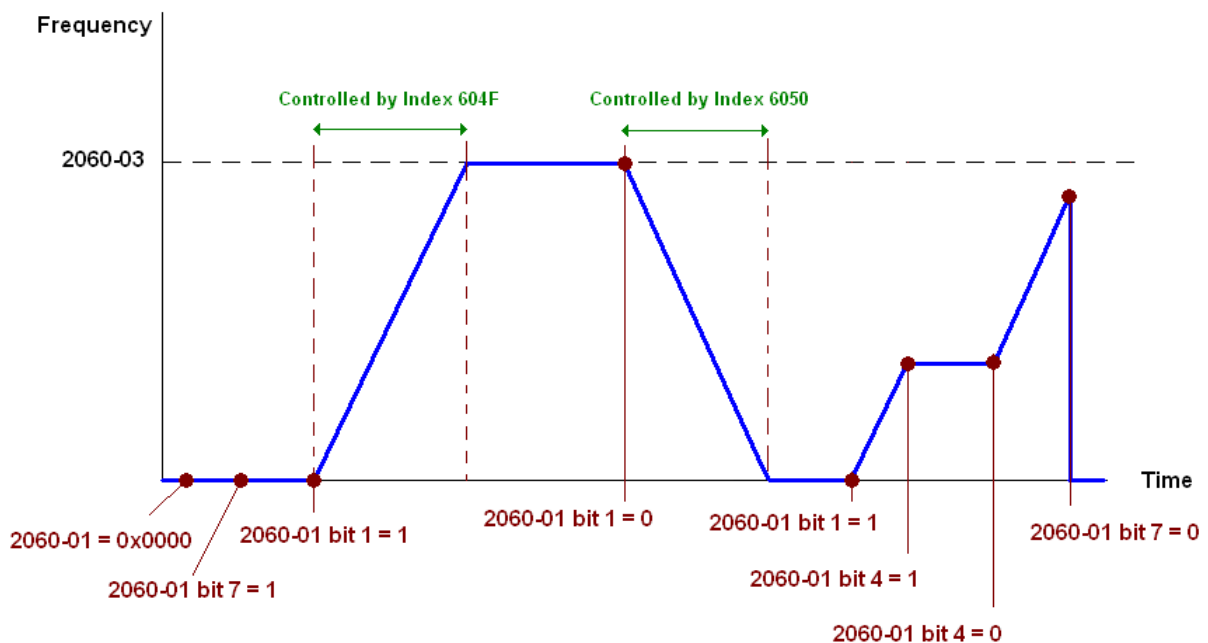

B-4 CANopen Supporting Index

VJ Index:

The parameter index corresponds as shown in this example:

Index	sub-Index
2000H + Group	member+1

For example:

Pr.01-01 (Source of operation command)

Group	-	member
01(01H)		01(01H)

Index = 2000H + 01H = 2001

Sub Index = 01H + 1H = 2H

VJ Control Index:

Delta Standard Mode (Old definition)

Index	Sub	Definition	Factory Setting	R/W	Size	Note	
2000H	2D	Pressure Command	0	RW	U16		
	2E	Flow Command	0	RW	U16		
2020H	0	Number	3	R	U8		
	1	Control word	0	RW	U16	Bit 1–0	00B: Disable
							01B: Stop
							10B: Disable
							11B: JOG Enable
						Bit3–2	Reserved
							Bit5–4
						01B: Direction forward	
						10B: Direction reverse	
						11B: Switch direction	
						Bit7–6	Reserved
	Bit11–8	Reserved					
	Bit12	Reserved					
	Bit14–13	00B: No function					
	01B: Operation command by the digital keypad						
						10B: Operation command according to Pr.01-01 setting	
						11B: Switch the source of operation command	
						Bit 15: Reserved	
2	Freq. command (XXX.XX Hz)	0	RW	U16			
3	Other trigger	0	RW	U16	Bit0	1: E.F. ON	
					Bit1	1: Reset	
					Bit15–3	Reserved	
2021H	0	Number	10	R	U8		
	1	Error code	0	R	U16		High byte: Warn Code Low Byte: Error Code
	2	AC motor drive status	0	R	U16	Bit 1–0	00B: Stop
							01B: Decelerate to stop
							10B: Waiting for operation command
							11B: In operation
						Bit 2	Reserved
						Bit 4–3	00B: Run forward
					01B: Switch from run in reverse		

Index	Sub	Definition	Factory Setting	R/W	Size	Note
						to run forward
						10B: Switch from run forward to run in reverse
						11B: Run in reverse
					Bit 7–5	Reserved
					Bit 8	1: Master Frequency command controlled by communication interface
					Bit 9	1: Master Frequency command controlled by analog / external terminal signal input
					Bit 10	1: Operation command controlled by communication interface
					Bit 11	1: Parameter lock
					Bit 12	Reserved
					Bit 15–13	Reserved
	3	Frequency command (XXX.XXHz)	0	R	U16	
	4	Output freq. (XXX.XX Hz)	0	R	U16	
	5	Output current (XXX.XX A)	0	R	U16	
	6	DC BUS voltage (XXX.X V)	0	R	U16	
	7	Output voltage (XXX.X V)	0	R	U16	
	8	Reserved	0	R	U16	
	9	Reserved	0	R	U16	
	A	Reserved	0	R	U16	
	B	Reserved	0	R	U16	
	C	Reserved	0	R	U16	
	D	Reserved	0	R	U16	
	E	Reserved	0	R	U16	
	F	Reserved	0	R	U16	
	10	Reserved	0	R	U16	
	17	Multi-function display (Pr.00-04)	0	R	U16	
2022H	0	Reserved	0	R	U16	
	1	Display output current (XX.XXA)	0	R	U16	
	2	Display counter value	0	R	U16	
	3	Display actual output frequency(XXX.XX Hz)	0	R	U16	
	4	Display DC-BUS voltage (XXX.X V)	0	R	U16	
	5	Display output voltage (XXX.X V)	0	R	U16	
	6	Display output power angle (XXX.X°)	0	R	U16	
	7	Display output power by U, V, W in kW (XX.XXX kW)	0	R	U16	
	8	Display actual motor speed (XXXXX rpm)	0	R	U16	
	9	Display estimate output torque (XXX.X%)	0	R	U16	
	A	Display PG feedback	0	R	U16	
	B	Reserved	0	R	U16	
	C	Display signal for PS analog	0	R	U16	

Index	Sub	Definition	Factory Setting	R/W	Size	Note
		input terminal, 4~20mA/ 0–10 V corresponds to 0–100% (to two decimal places)				
	D	Display signal of PI analog input terminal, 0~10 V corresponds to 0 ~100% (to two decimal places)	0	R	U16	
	F	Display the IGBT temperature of drive power module (XXX.X°C)	0	R	U16	
	10	Display motor drive's capacitor temperature (XXX.X°C)	0	R	U16	
	11	The status of digital input (ON/OFF), refer to Pr.02-12	0	R	U16	
	12	The status of digital output (ON/OFF), refer to Pr.02-18	0	R	U16	
	13	Reserved	0	R	U16	
	14	The corresponding CPU pin status of digital input	0	R	U16	
	15	The corresponding CPU pin status of digital output	0	R	U16	
	16	Reserved	0	R	U16	
	17	Reserved	0	R	U16	
	18	Reserved .	0	R	U16	
	1A	Display signal of QI analog input terminal, 0~10 V corresponds to 0 ~100% (to two decimal places)	0	R	U16	
	1B	Display actual pressure (Bar)	0	R	U16	
	1C	Display kw/ hr	0	R	U16	
	1D	Display motor's temperature °C	0	R	U16	
	1E	Display motor drive's over load in %	0	R	U16	
	1F	Display motor's over load in % of HES type A	0	R	U16	
	20	Display current at braking (Ampere)	0	R	U16	
	21	Display braking chopper's temperature °C	0	R	U16	

Delta Standard Mode (New definition)

Index	sub	R/W	Size	Descriptions			Speed Mode
				bit	Definition	Priority	
2060h	00h	R	U8				
	01h	RW	U16	0	Ack	4	0: fcmd =0 1: fcmd = Fset(Fpid)
				1	Dir	4	0: FWD run command 1: REV run command
				2			
				3	Halt	3	0: Drive runs until target speed is reached 1: Drive stops by declaration setting
				4	Hold	4	0: Drive runs until target speed is reached 1: Frequency stop at current frequency
				5	JOG	4	0:JOG OFF Pulse 1:JOG RUN
				6	QStop	2	Quick Stop
				7	Power	1	0: Power OFF 1: Power ON
				8	Ext_Cmd2	4	0 → 1: Clear the absolute position.
				14–8			
				15	RST	4	Pulse 1: Fault code cleared
	02h	RW	U16		Mode Cmd		0: Speed Mode
	03h	RW	U16				Speed command (unsigned decimal)
04h	RW	U16					
05h	RW	S32					
06h	RW						
07h	RW	S16					
08h	RW	U16					
2061h	01h	R	U16	0	Arrive		Frequency reached
				1	Dir		0: Motor FWD run 1: Motor REV run
				2	Warn		Warning
				3	Error		Error detected
				4			
				5	JOG		JOG
				6	QStop		Quick stop
				7	Power ON		Switch ON
	15–8						
	02h	R					
	03h	R	U16				Actual output frequency
	04h	R					
	05h	R	S32				Actual position (absolute)
06h	R						
07h	R	S16				Actual torque	

DS402 Standard

Index	Sub	Definition	Factory Setting	R/W	Size	Unit	PDO Map	Mode	Note
6007h	0	Abort connection option code	2	RW	S16		Yes		0: No action
									2: Disable voltage
									3: Quick Stop
603Fh	0	Error code	0	RO	U16		Yes		
6040h	0	Control word	0	RW	U16		Yes		
6041h	0	Status word	0	RO	U16		Yes		
6042h	0	vl target velocity	0	RW	S16	rpm	Yes	vl	
6043h	0	vl velocity demand	0	RO	S16	rpm	Yes	vl	
6044h	0	vl control effort	0	RO	S16	rpm	Yes	vl	
604Fh	0	vl ramp function time	10000	RW	U32	1ms	Yes	vl	Unit must be 100 ms, and check if the setting is 0.
6050h	0	vl slow down time	10000	RW	U32	1ms	Yes	vl	
6051h	0	vl quick stop time	1000	RW	U32	1ms	Yes	vl	
605Ah	0	Quick stop option code	2	RW	S16		No		0: Disable drive function
									1: Slow down on slow down ramp
									2: Slow down on quick stop ramp
									5: Slow down on slow down ramp and stay in QUICK STOP
									6: Slow down on quick stop ramp and stay in QUICK STOP
605Ch	0	Disable operation option code	1	RW	S16		No		0: Disable drive function 1: Slow down with slow down ramp; disable the drive function
6060h	0	Mode of operation	2	RW	S8		Yes		2: Velocity mode
6061h	0	Mode of operation display	2	RO	S8		Yes		Same as above

B-5 CANopen LED Function

There are two CANopen flash signs: RUN and ERR.

RUN LED:

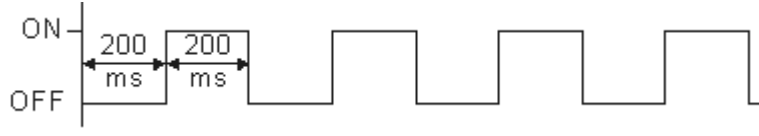
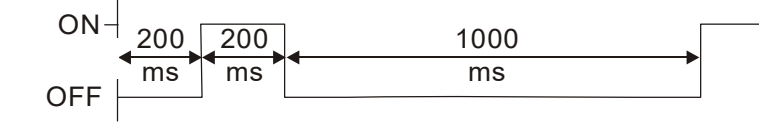
LED status	Condition	CANopen State
OFF	Keep lighting off	Initial
Blinking		Pre-operation
Single flash		Stopped
ON	Keep lighting on	Operation

ERR LED:

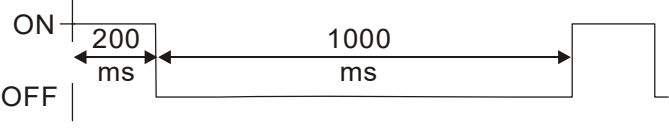
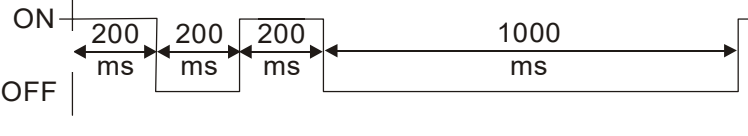
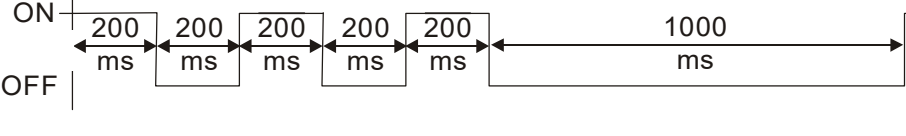
LED status	Condition/ State
OFF	No Error
Single flash	One Message fail 
Double flash	Guarding fail or heartbeat fail 
Triple flash	SYNC fail 
ON	Bus off

Appendix C: Activate the Oil Pump, Step by Step

Step by Step

Step 1. Verify if there's enough hydraulic oil in the oil tank before you turn on the power.

Step 2. After you turn on the power of the hybrid servo drive, use jogging to enable the oil pump. The jogging here means pressing ON button and release right away. Then you will hear the sound of oil pipe sucks in air. Repeat this step few more times until you no longer hear the sound of sucking in air.

Step 3. After you clear the air in the oil tank. Run the motor without any load at a rotation speed of 1200 RPM for 15minutes.

Step 4. After you finish Step 3 and before you start to test machinery, increase progressively the pressure by following the 5 stages below

For example: the maximum pressure is 1790bar and the maximum speed is 1200rpm.

Apply jogging method while increase the pressure from stage 1 to stage 5.

Stage 1: 30bar

Stag 2: 70 bar

Stage 3: 100bar

Stage 4:140bar

Stage 5:170bar

You need to finish the 5 stages above then you can start to test the machinery