

ROBOTICS

Product manual

IRB 660



Trace back information:
Workspace 22D version a8
Checked in 2022-12-09
Skribenta version 5.5.019

Product manual
IRB 660 - 180/3.15
IRB 660 - 250/3.15

IRC5, OmniCore

Document ID: 3HAC025755-001

Revision: AC

The information in this manual is subject to change without notice and should not be construed as a commitment by ABB. ABB assumes no responsibility for any errors that may appear in this manual.

Except as may be expressly stated anywhere in this manual, nothing herein shall be construed as any kind of guarantee or warranty by ABB for losses, damage to persons or property, fitness for a specific purpose or the like.

In no event shall ABB be liable for incidental or consequential damages arising from use of this manual and products described herein.

This manual and parts thereof must not be reproduced or copied without ABB's written permission.

Keep for future reference.

Additional copies of this manual may be obtained from ABB.

Original instructions.

© Copyright 2006-2022 ABB. All rights reserved.
Specifications subject to change without notice.

Table of contents

Overview of this manual	9
Product documentation	16
How to read the product manual	18
1 Safety	19
1.1 Safety information	19
1.1.1 Limitation of liability	19
1.1.2 Requirements on personnel	20
1.2 Safety signals and symbols	21
1.2.1 Safety signals in the manual	21
1.2.2 Safety symbols on manipulator labels	23
1.3 Robot stopping functions	29
1.4 Safety during installation and commissioning	30
1.5 Safety during operation	33
1.6 Safety during maintenance and repair	34
1.6.1 Safety during maintenance and repair	34
1.6.2 Emergency release of the robot axes	37
1.6.3 Brake testing	38
1.7 Safety during troubleshooting	39
1.8 Safety during decommissioning	40
2 Installation and commissioning	41
2.1 Introduction to installation and commissioning	41
2.2 Unpacking	42
2.2.1 Pre-installation procedure	42
2.2.2 Working range and type of motion	46
2.2.3 Risk of tipping/stability	48
2.2.4 The unit is sensitive to ESD	49
2.3 On-site installation	50
2.3.1 Lifting robot with fork lift	50
2.3.2 Lifting robot with roundslings	55
2.3.3 Lifting robot with lifting accessory (recommended lifting method)	58
2.3.4 Manually releasing the brakes	61
2.3.5 Lifting the base plate	63
2.3.6 Securing the base plate	64
2.3.7 Orienting and securing the robot	69
2.3.8 Fitting equipment on robot	72
2.3.9 Safety lamp (option for IRC5)	76
2.3.10 Loads fitted to the robot, stopping time and braking distances	77
2.3.11 Extended working range, axis 1 (option)	78
2.4 Restricting the working range	80
2.4.1 Axes with restricted working range	80
2.4.2 Mechanically restricting the working range of axis 1	81
2.5 Robot in cold environments	83
2.5.1 Start of robot in cold environments	83
2.6 Electrical connections	84
2.6.1 Robot cabling and connection points	84
2.6.2 Customer connectors on the manipulator	87
2.7 Test run after installation, maintenance, or repair	89
3 Maintenance	91
3.1 Introduction	91
3.2 Maintenance schedule and expected component life	92
3.2.1 Specification of maintenance intervals	92
3.2.2 Maintenance schedule	93
3.2.3 Expected component life	95

Table of contents

3.3	Inspection activities	96
3.3.1	Inspecting the oil level in axis-1 gearbox	96
3.3.2	Inspecting, oil level gearbox axes 2 - 3	98
3.3.3	Inspecting, oil level gearbox axis 6	101
3.3.4	Inspecting, balancing device bearings and piston rod guide ring	103
3.3.5	Inspecting, cable harness	107
3.3.6	Inspecting the information labels	110
3.3.7	Inspecting the axis-1 mechanical stop pin	112
3.3.8	Inspecting the additional mechanical stops	114
3.3.9	Inspection, dampers	116
3.3.10	Inspecting the signal lamp (option)	118
3.4	Replacement/changing activities	120
3.4.1	Type of lubrication in gearboxes	120
3.4.2	Changing oil, axis-1 gearbox	121
3.4.3	Changing oil, gearbox axes 2 and 3	124
3.4.4	Changing oil, gearbox axis 6	128
3.4.5	Replacing the SMB battery	130
3.5	Lubrication activities	134
3.5.1	Lubricating balancing device bearings and piston rod	134
3.6	Cleaning activities	137
3.6.1	Cleaning the IRB 660	137
4	Repair	139
4.1	Introduction	139
4.2	General procedures	140
4.2.1	Performing a leak-down test	140
4.2.2	Mounting instructions for bearings	141
4.2.3	Mounting instructions for sealings	143
4.2.4	Cut the paint or surface on the robot before replacing parts	146
4.2.5	The brake release buttons may be jammed after service work	147
4.3	Complete robot	148
4.3.1	Replacing cable harness, lower end (axes 1-3)	148
4.3.2	Replacing the cable harness, upper end (incl. axis 6)	156
4.3.3	Replacing the base, including axis 1 gearbox	162
4.4	Upper and lower arm	170
4.4.1	Replacing the turning disk	170
4.4.2	Replacement of tilthouse unit	174
4.4.3	Replacement of upper arm	188
4.4.4	Replacement of linkage - upper rod	198
4.4.5	Replacing the linkage - lower rod	202
4.4.6	Replacement of linkage - link	206
4.4.7	Replacing the parallel rod	214
4.4.8	Replacing the complete lower arm	219
4.4.9	Replacement of parallel arm	227
4.5	Frame and base	234
4.5.1	Replacing the balancing device	234
4.5.2	Replacing the SMB unit	242
4.5.3	Replacing the brake release board	245
4.6	Motors	249
4.6.1	Replacing motor, axis 1	249
4.6.2	Replacing motors, axes 2 and 3	256
4.6.3	Replacing motor, axis 6	267
4.7	Gearboxes	274
4.7.1	Replacing the axis 1 gearbox	274
4.7.2	Replacing the gearbox, axes 2- 3	285
4.7.3	Replacing gearbox axis 6	297

5	Calibration	303
5.1	Introduction to calibration	303
5.1.1	Introduction and calibration terminology	303
5.1.2	Calibration methods	304
5.1.3	When to calibrate	305
5.2	Synchronization marks and axis movement directions	306
5.2.1	Synchronization marks and synchronization position for axes	306
5.2.2	Calibration movement directions for all axes	307
5.3	Updating revolution counters	308
5.3.1	Updating revolution counters on IRC5 robots	308
5.3.2	Updating revolution counters on OmniCore robots	312
5.4	Calibrating with Axis Calibration method	314
5.4.1	Description of Axis Calibration	314
5.4.2	Calibration tools for Axis Calibration	317
5.4.3	Installation locations for the calibration tools	319
5.4.4	Axis Calibration - Running the calibration procedure	321
5.4.5	Reference calibration	325
5.5	Verifying the calibration	327
5.6	Checking the synchronization position	328
6	Decommissioning	331
6.1	Introduction to decommissioning	331
6.2	Environmental information	332
6.3	Scrapping of robot	334
6.4	Decommissioning of balancing device	335
7	Reference information	339
7.1	Introduction	339
7.2	Applicable standards	340
7.3	Unit conversion	341
7.4	Screw joints	342
7.5	Weight specifications	345
7.6	Standard tools	346
7.7	Special tools	347
7.8	Lifting accessories and lifting instructions	349
8	Spare part lists	351
8.1	Spare part lists and illustrations	351
9	Circuit diagrams	353
9.1	Circuit diagrams	353
	Index	355

This page is intentionally left blank

Overview of this manual

About this manual

This manual contains instructions for:

- mechanical and electrical installation of the robot
- maintenance of the robot
- mechanical and electrical repair of the robot.

The manual also contains reference information for all procedures detailed in the manual.

Usage

This manual should be used during:

- installation, from lifting the robot to its work site and securing it to the foundation, to making it ready for operation
- maintenance work
- repair work.

Who should read this manual?

This manual is intended for:

- installation personnel
- maintenance personnel
- repair personnel.

Prerequisites

Maintenance/repair/installation personnel working with an ABB Robot must:

- be trained by ABB and have the required knowledge of mechanical and electrical installation/repair/maintenance work.

Product manual scope

The manual covers covers all variants and designs of the IRB 660. Some variants and designs may have been removed from the business offer and are no longer available for purchase.

Organization of chapters

The manual is organized in the following chapters:

Chapter	Contents
Safety	Safety information that must be read through before performing any installation or service work on robot. Contains general safety aspects as well as more specific information about how to avoid personal injuries and damage to the product.
Installation and commissioning	Required information about lifting and installation of the robot.
Maintenance	Step-by-step procedures that describe how to perform maintenance of the robot. Based on a maintenance schedule that may be used in the work of planning periodical maintenance.

Continues on next page

Overview of this manual

Continued

Chapter	Contents
Repair	Step-by-step procedures that describe how to perform repair activities of the robot. Based on available spare parts.
Calibration	Calibration procedures and general information about calibration.
Decommissioning	Environmental information about the robot and its components.
Reference information	Useful information when performing installation, maintenance or repair work. Includes lists of necessary tools, additional documents, safety standards etc.
Spare part / part list	Complete spare part list of the robot components, shown in exploded views.
Exploded views	Detailed illustrations of the robot with reference numbers to the part list.
Circuit diagram	Reference to the circuit diagram for the robot.

References

General

Document name	Document ID
<i>Product manual, spare parts - IRB 660</i>	<i>3HAC049102-001</i>
<i>Circuit diagram - IRB 660</i>	<i>3HAC025691-001</i>
<i>Technical reference manual - Lubrication in gearboxes</i>	<i>3HAC042927-001</i>
<i>Safety manual for robot - Manipulator and IRC5 or OmniCore controllerⁱ</i>	<i>3HAC031045-001</i>

ⁱ This manual contains all safety instructions from the product manuals for the manipulators and the controllers.

OmniCore robots

Document name	Document ID
<i>Product specification - IRB 660</i>	<i>3HAC081955-001</i>
<i>Product manual - OmniCore V250XT Type A</i>	<i>3HAC084692-001</i>
<i>Product manual - OmniCore V250XT</i>	<i>3HAC073447-001</i>
<i>Operating manual - OmniCore</i>	<i>3HAC065036-001</i>
<i>Technical reference manual - System parameters</i>	<i>3HAC065041-001</i>

IRC5 robots

Document name	Document ID
<i>Product specification - IRB 660</i>	<i>3HAC023932-001</i>
<i>Product manual - IRC5</i> IRC5 with main computer DSQC 639.	<i>3HAC021313-001</i>
<i>Product manual - IRC5</i> IRC5 with main computer DSQC1000.	<i>3HAC047136-001</i>
<i>Operating manual - IRC5 with FlexPendant</i>	<i>3HAC050941-001</i>
<i>Operating manual - Calibration Pendulum</i>	<i>3HAC16578-1</i>
<i>Operating manual - Service Information System</i>	<i>3HAC050944-001</i>

Continues on next page

Document name	Document ID
Application manual - Additional axes and stand alone controller	3HAC051016-001
Technical reference manual - System parameters	3HAC050948-001
Application manual - CalibWare Field	3HAC030421-001

Revisions

Revision	Description
-	First edition
A	Detailed illustrations added in some procedures. Art. no. on tools added. Chapter "Replacement of tilthouse unit" has been changed, in order to make it easier to follow the procedure.
B	Changes made in: <ul style="list-style-type: none"> Prerequisites in section Overview Oil change in section Maintenance This revision also includes the following additions and/or changes: <ul style="list-style-type: none"> The section "Type of oil in gearboxes" in chapter Maintenance has been updated according to changes made in oil types and intervals for oil change. Section "Replacement of Cable harness lower end" in chapter Repair has been updated. Section "Replacement of Parallel rod" in chapter Repair has been updated. Section "Replacement of Balancing device" in chapter Repair has been updated. Section "Replacement of Gearbox axis 6" in chapter Repair has been updated. Values for tightening torque on M24 screws in chapter Reference information, added. New revision on Circuit diagrams.
C	This revision includes the following additions and/or changes: <ul style="list-style-type: none"> Section "Securing the robot" in Installation chapter has been removed. Content is not applicable to IRB 660. Section <i>What is an emergency stop?</i> added to chapter Safety Section <i>Maintenance schedule</i> in chapter Maintenance: Intervals for inspection activities and oilchanges have been revised Section <i>Maintenance schedule</i> in chapter Maintenance: Overhaul of robot is new Section <i>Maintenance schedule</i> in chapter Maintenance: The information about Service Information System (SIS) has been updated Section <i>Maintenance schedule</i> in chapter Maintenance: Intervals for replacement of battery pack changed Section <i>Expected lifetime</i> in chapter Maintenance: The lifetime of certain parts has been revised Section <i>Cleaning of robot</i> updated
D	This revision includes the following additions and/or changes: <ul style="list-style-type: none"> Instruction for how to inspect oil level corrected, see Inspecting, oil level gearbox axis 6 on page 101. Circuit diagrams are not included in this document but delivered as separate files. See Circuit diagrams on page 353. List of safety standards updated. Decommissioning chapter added.

Continues on next page

Revision	Description
	<ul style="list-style-type: none"> The lifetime of certain parts has been updated, see Expected component life on page 95. <p>The chapter <i>Safety</i> updated with:</p> <ul style="list-style-type: none"> Updated safety signal graphics for the levels <i>Danger</i> and <i>Warning</i>, see Safety signals in the manual on page 21. New safety labels on the manipulators, see Safety symbols on manipulator labels on page 23. Revised terminology: <i>robot</i> replaced with <i>manipulator</i>.
E	<p>This revision includes the following updates:</p> <ul style="list-style-type: none"> Maximum deviation changed, see Securing the base plate on page 64.
F	<p>This revision includes following updates:</p> <ul style="list-style-type: none"> Added index words throughout the manual. Inspection method of oil level in gearbox, axis 6, is changed, see Inspecting, oil level gearbox axis 6 on page 101. Position numbers in figure corrected, see Location of dampers on page 116. Removed information about lubricating attachment screws, removed tightening torque and screw dimension for axis 2 and 3 and added screw dimension for axis 1, see Inspecting the additional mechanical stops on page 114. Changed tightening torque of fork lift adapters, from 60 Nm to 270 Nm, see Lifting robot with fork lift on page 52. Changed article numbers of robot power cables, see Robot cable, power on page 85. Information about restricting and extending the working range of axis 1 is now separated, see Mechanically restricting the working range of axis 1 on page 81 and the new section Extended working range, axis 1 (option) on page 78. Also added signal about option 561-1 in section Inspecting the axis-1 mechanical stop pin on page 112. Added detailed information about how to decommission the balancing device, see Decommissioning of balancing device on page 335. Added new safety symbols, see Safety symbols on manipulator labels on page 23.
G	<p>This revision includes the following updates:</p> <ul style="list-style-type: none"> A new block, about general illustrations, added in section How to read the product manual on page 18. Added a KM10 socket to the list of required equipment and the instructions when replacing the lower rod, see section Replacing the linkage - lower rod on page 202. The tool is also added to the list of Special tools in the Reference chapter. Added instructions for securing parallel arm and lower arm to each other before removing the lower arm, see Replacing the complete lower arm on page 219. Added guide sleeves to hold the axes 2/3 sealing in place when refitting the lower arm, see Replacing the complete lower arm on page 219. Made minor corrections and improvements in the complete instruction for how to replace the lower arm system, see Replacing the complete lower arm on page 219. Made minor corrections and improvements in the complete instruction for how to replace the parallel arm, see Replacement of parallel arm on page 227.

Revision	Description
	<ul style="list-style-type: none"> • Made minor corrections and improvements in the complete instruction for how to replace the axis 1 gearbox, see Replacing the axis 1 gearbox on page 274. • Some general tightening torques have been changed/added, see updated values in Screw joints on page 342. • Added information about batteries.
H	<p>This revision includes the following updates:</p> <ul style="list-style-type: none"> • The maximum allowed deviation in levelness of the base plate is changed, see Securing the base plate on page 64. • Reference to Hilti standard added to the foundation recommendation for the base plate and class designation for foundation is changed to European standard C25/C30 (previously Swedish standard K25/K30), see Securing the base plate on page 64. • Corrections and improvements are made in the instruction for how to replace the axis-2 and axis-3 gearbox, see Replacing the gearbox, axes 2- 3 on page 285. • All data about type of lubrication in gearboxes is moved from the manual to a separate lubrication manual, see Type and amount of oil in gearboxes on page 120. • Added spare part numbers for the customer connection kits and the base plate, see Spare parts - option in Product manual, spare parts - IRB 660. • A new SMB unit and battery is introduced, with longer battery life-time.
J	<p>This revision includes the following updates:</p> <ul style="list-style-type: none"> • New article number for painted motor added to spare parts, see Spare parts - frame to lower arm in Product manual, spare parts - IRB 660. • Spare part number on item 102, 104 and 107, frame to base changed. See Spare parts - frame to Base in Product manual, spare parts - IRB 660. • Added information about risks when scrapping a decommissioned robot, see Scrapping of robot on page 334. • Spare parts and exploded views are not included in this document but delivered as a separate document. See Product manual, spare parts - IRB 660. • Article number for lubrication tool changed, see Lubricating balancing device bearings and piston rod on page 134
K	<p>This revision includes the following updates:</p> <ul style="list-style-type: none"> • The maximum allowed deviation in levelness of the base plate and foundation is changed, see Securing the base plate on page 64. • Added tightening torque for R1.SMB and 7th axis connector, see Replacing cable harness, lower end (axes 1-3) on page 148. • Minor corrections.
L	<p>This revision includes the following updates:</p> <ul style="list-style-type: none"> • Lifting tools updated (guide pin 3HAC7601-086 and guide pin 3HAC7601-087 removed) • Special tools updated (Pressing, inner ring 3HAC023112-008 removed) • Illustrations of SMB battery RMU improved.
M	<p>Published in release R16.2. The following updates are done in this revision:</p> <ul style="list-style-type: none"> • Drawing of base plate is not available for purchase, faulty information removed in Securing the base plate on page 64. • Corrections due to updates in terminology. • New standard calibration method is introduced (Axis Calibration). See Calibration on page 303.

Continues on next page

Revision	Description
	<ul style="list-style-type: none"> Information about grounding point added. See Robot cabling and connection points on page 84.
N	<p>Published in release R17.2. The following updates are made in this revision:</p> <ul style="list-style-type: none"> Caution about removing metal residues added in sections about SMB boards. Information about minimum resonance frequency added. Bending radius for static floor cables added. Updated list of applicable standards. Added text regarding overhaul in section specification of maintenance intervals. Updated the section Start of robot in cold environments on page 83. Updated information regarding replacement of brake release board. Updated information regarding disconnecting and reconnecting battery cable to serial measurement board. Updated information regarding replacing of balancing device. Definition of reference calibration clarified.
P	<p>Published in release R18.1. The following updates are made in this revision:</p> <ul style="list-style-type: none"> Information added about fatigue to Axis Calibration tool, see Calibration tools for Axis Calibration on page 317. Added sections in General procedures on page 140. Safety restructured. New spare part number brake release board (was DSQC563). Note added to calibration chapter to emphasize the requirement of equally dressed robot when using previously created reference calibration values. Information about myABB Business Portal added.
Q	<p>Published in release R18.2. The following updates are done in this revision:</p> <ul style="list-style-type: none"> Added locating hole position in mounting flange view.
R	<p>Published in release R18.2. The following updates are done in this revision:</p> <ul style="list-style-type: none"> Updated references.
S	<p>Published in release 19B. The following updates are made in this revision:</p> <ul style="list-style-type: none"> New touch up color Graphite White available. See Cut the paint or surface on the robot before replacing parts on page 146. Tightening torque for oil plug axis 6 changed to 20 Nm. New adapter for axis-3 shaft replacement and updated article number for KM12 socket for axis-3 and axis-2 shaft replacements. See Replacement of upper arm on page 188.
T	<p>Published in release 19C. The following updates are made in this revision:</p> <ul style="list-style-type: none"> Added information regarding the support rings of the upper arm housing, see Replacement of upper arm on page 188.
U	<p>Published in release 19D. The following updates are made in this revision:</p> <ul style="list-style-type: none"> Added press tool for installation of support rings in the upper arm housing, see Replacement of upper arm on page 188. Sealing compound Permatex No. 3 replaced by Trans7 from Trans Clear.
V	<p>Published in release 20A. The following updates are made in this revision:</p> <ul style="list-style-type: none"> Clarified and added information in mounting instructions for rotating sealings, see Mounting instructions for sealings on page 143. Clarified text about position of robot and added table with dependencies between axes during Axis Calibration. Changed tightening torque for axis-2 and axis-3 shaft, see Replacement of upper arm on page 188 and increased the torque span for standard torque wrench, see Standard tools on page 346.

Continues on next page

Revision	Description
W	Published in release 20C. The following updates are made in this revision: <ul style="list-style-type: none"> • Changed tightening torques on the wrist oil plugs. • Removed lifting tool for axis-2 and axis-3 gearbox from the special tools list (lifting method was changed in previous revision).
X	Published in release 21B. The following updates are made in this revision: <ul style="list-style-type: none"> • Lubrication tool number changed, see Replacement of linkage - link on page 206. • New number and instruction for press tool, parallel arm, see Replacement of parallel arm on page 227. • New number and instruction for press tool, , see Replacement of tilthouse unit on page 174 . • New number and instruction for press tool, linkage - link, see Replacement of linkage - link on page 206. • Number for Lubrication tool number changed, see Required equipment on page 135. • Text regarding fastener quality is updated, see Fastener quality on page 75.
Y	Published in release 21C. The following updates are made in this revision: <ul style="list-style-type: none"> • Info about option Extended working range included, see Extended working range, axis 1 (option) on page 78.
Z	Published in release 21D. The following updates are made in this revision: <ul style="list-style-type: none"> • New section regarding customer connectors added, see Customer connectors on the manipulator.
AA	Published in release 22A. The following updates are done in this revision: <ul style="list-style-type: none"> • Updated information about Gleitmo treated screws, see Screw joints on page 342. • Removed information about position switches as they are no longer available.
AB	Published in release 22C. The following updates are done in this revision: <ul style="list-style-type: none"> • Added information for the OmniCore robot controller. • Corrected article number for lubrication tool intended for lubrication of balancing device bearings and piston rod. Incorrect number 3HAC5222-1 is replaced with correct number 3HAC5222-2.
AC	Published in release 22D. The following updates are done in this revision: <ul style="list-style-type: none"> • Added a step for overall inspection of cabling after cable harness has been replaced. • Customer connections; correction of illustration.

Product documentation

Categories for user documentation from ABB Robotics

The user documentation from ABB Robotics is divided into a number of categories. This listing is based on the type of information in the documents, regardless of whether the products are standard or optional.



Tip

All documents can be found via myABB Business Portal, www.abb.com/myABB.

Product manuals

Manipulators, controllers, DressPack/SpotPack, and most other hardware is delivered with a **Product manual** that generally contains:

- Safety information.
- Installation and commissioning (descriptions of mechanical installation or electrical connections).
- Maintenance (descriptions of all required preventive maintenance procedures including intervals and expected life time of parts).
- Repair (descriptions of all recommended repair procedures including spare parts).
- Calibration.
- Troubleshooting.
- Decommissioning.
- Reference information (safety standards, unit conversions, screw joints, lists of tools).
- Spare parts list with corresponding figures (or references to separate spare parts lists).
- References to circuit diagrams.

Technical reference manuals

The technical reference manuals describe reference information for robotics products, for example lubrication, the RAPID language, and system parameters.

Application manuals

Specific applications (for example software or hardware options) are described in **Application manuals**. An application manual can describe one or several applications.

An application manual generally contains information about:

- The purpose of the application (what it does and when it is useful).
- What is included (for example cables, I/O boards, RAPID instructions, system parameters, software).
- How to install included or required hardware.
- How to use the application.

Continues on next page

- Examples of how to use the application.

Operating manuals

The operating manuals describe hands-on handling of the products. The manuals are aimed at those having first-hand operational contact with the product, that is production cell operators, programmers, and troubleshooters.

How to read the product manual

Reading the procedures

The procedures contain references to figures, tools, material, and so on. The references are read as described below.

References to figures

The procedures often include references to components or attachment points located on the manipulator/controller. The components or attachment points are marked with *italic text* in the procedures and completed with a reference to the figure where the current component or attachment point is shown.

The denomination in the procedure for the component or attachment point corresponds to the denomination in the referenced figure.

The table below shows an example of a reference to a figure from a step in a procedure.

	Action	Note/Illustration
8.	Remove the <i>rear attachment screws, gearbox</i> .	Shown in the figure Location of gearbox on page xx .

References to required equipment

The procedures often include references to equipment (spare parts, tools, etc.) required for the different actions in the procedure. The equipment is marked with *italic text* in the procedures and completed with a reference to the section where the equipment is listed with further information, that is article number and dimensions.

The designation in the procedure for the component or attachment point corresponds to the designation in the referenced list.

The table below shows an example of a reference to a list of required equipment from a step in a procedure.

	Action	Note/Illustration
3.	Fit a new <i>sealing, axis 2</i> to the gearbox.	Art. no. is specified in Required equipment on page xx .

Safety information

The manual includes a separate safety chapter that must be read through before proceeding with any service or installation procedures. All procedures also include specific safety information when dangerous steps are to be performed.

Read more in the chapter [Safety on page 19](#).

Illustrations

The robot is illustrated with general figures that does not take painting or protection type in consideration.

Likewise, certain work methods or general information that is valid for several robot models, can be illustrated with illustrations that show a different robot model than the one that is described in the current manual.

1 Safety

1.1 Safety information

1.1.1 Limitation of liability

Limitation of liability

Any information given in this manual regarding safety must not be construed as a warranty by ABB that the industrial robot will not cause injury or damage even if all safety instructions are complied with.

The information does not cover how to design, install and operate a robot system, nor does it cover all peripheral equipment that can influence the safety of the robot system.

In particular, liability cannot be accepted if injury or damage has been caused for any of the following reasons:

- Use of the robot in other ways than intended.
- Incorrect operation or maintenance.
- Operation of the robot when the safety devices are defective, not in their intended location or in any other way not working.
- When instructions for operation and maintenance are not followed.
- Non-authorized design modifications of the robot.
- Repairs on the robot and its spare parts carried out by in-experienced or non-qualified personnel.
- Foreign objects.
- Force majeure.

Spare parts and equipment

ABB supplies original spare parts and equipment which have been tested and approved. The installation and/or use of non-original spare parts and equipment can negatively affect the safety, function, performance, and structural properties of the robot. ABB is not liable for damages caused by the use of non-original spare parts and equipment.

1 Safety

1.1.2 Requirements on personnel

1.1.2 Requirements on personnel

General

Only personnel with appropriate training are allowed to install, maintain, service, repair, and use the robot. This includes electrical, mechanical, hydraulics, pneumatics, and other hazards identified in the risk assessment.

Persons who are under the influence of alcohol, drugs or any other intoxicating substances are not allowed to install, maintain, service, repair, or use the robot.

The plant liable must make sure that the personnel is trained on the robot, and on responding to emergency or abnormal situations.

Personal protective equipment

Use personal protective equipment, as stated in the instructions.

1.2 Safety signals and symbols

1.2.1 Safety signals in the manual







Introduction to safety signals

This section specifies all safety signals used in the user manuals. Each signal consists of:

- A caption specifying the hazard level (DANGER, WARNING, or CAUTION) and the type of hazard.
- Instruction about how to reduce the hazard to an acceptable level.
- A brief description of remaining hazards, if not adequately reduced.

Hazard levels

The table below defines the captions specifying the hazard levels used throughout this manual.

Symbol	Designation	Significance
	DANGER	Signal word used to indicate an imminently hazardous situation which, if not avoided, will result in serious injury.
	WARNING	Signal word used to indicate a potentially hazardous situation which, if not avoided, could result in serious injury.
	ELECTRICAL SHOCK	Signal word used to indicate a potentially hazardous situation related to electrical hazards which, if not avoided, could result in serious injury.
	CAUTION	Signal word used to indicate a potentially hazardous situation which, if not avoided, could result in slight injury.
	ELECTROSTATIC DISCHARGE (ESD)	Signal word used to indicate a potentially hazardous situation which, if not avoided, could result in severe damage to the product.
	NOTE	Signal word used to indicate important facts and conditions.

Continues on next page

1 Safety

1.2.1 Safety signals in the manual

Continued

Symbol	Designation	Significance
 A yellow lightbulb icon with five short lines radiating from the top, indicating a tip or important information.	TIP	Signal word used to indicate where to find additional information or how to do an operation in an easier way.

1.2.2 Safety symbols on manipulator labels

Introduction to symbols

This section describes safety symbols used on labels (stickers) on the manipulator. Symbols are used in combinations on the labels, describing each specific warning. The descriptions in this section are generic, the labels can contain additional information such as values.



Note

The symbols on the labels on the product must be observed. Additional symbols added by the integrator must also be observed.



Types of symbols

Both the manipulator and the controller are marked with symbols, containing important information about the product. This is important for all personnel handling the robot, for example during installation, service, or operation.

The safety labels are language independent, they only use graphics. See [Symbols on safety labels on page 23](#).

The information labels can contain information in text.

Symbols on safety labels



Symbol	Description
 xx0900000812	Warning! Warns that an accident <i>may</i> occur if the instructions are not followed that can lead to serious injury, possibly fatal, and/or great damage to the product. It applies to warnings that apply to danger with, for example, contact with high voltage electrical units, explosion or fire risk, risk of poisonous gases, risk of crushing, impact, fall from height, etc.
 xx0900000811	Caution! Warns that an accident may occur if the instructions are not followed that can result in injury and/or damage to the product. It also applies to warnings of risks that include burns, eye injury, skin injury, hearing damage, crushing or slipping, tripping, impact, fall from height, etc. Furthermore, it applies to warnings that include function requirements when fitting and removing equipment where there is a risk of damaging the product or causing a breakdown.
 xx0900000839	Prohibition Used in combinations with other symbols.

Continues on next page



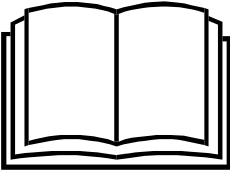
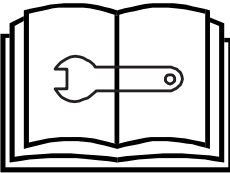
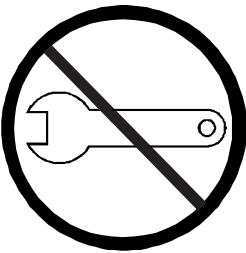
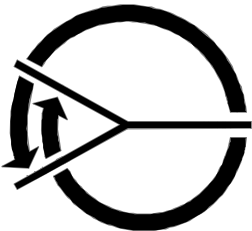

1 Safety

1.2.2 Safety symbols on manipulator labels

Continued

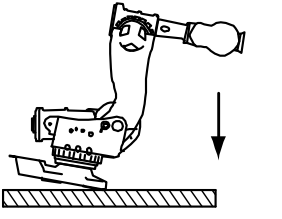
Symbol	Description
 xx0900000813	See user documentation Read user documentation for details. Which manual to read is defined by the symbol: <ul style="list-style-type: none">• No text: <i>Product manual</i>.• EPS: <i>Application manual - Electronic Position Switches</i>.
 xx0900000816	Before disassembly, see product manual
 xx0900000815	Do not disassemble Disassembling this part can cause injury.
 xx0900000814	Extended rotation This axis has extended rotation (working area) compared to standard.
 xx0900000808	Brake release Pressing this button will release the brakes. This means that the robot arm can fall down.

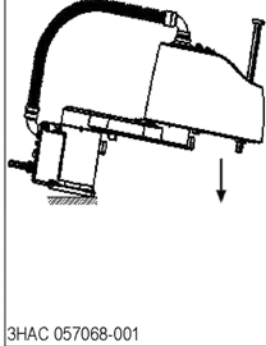
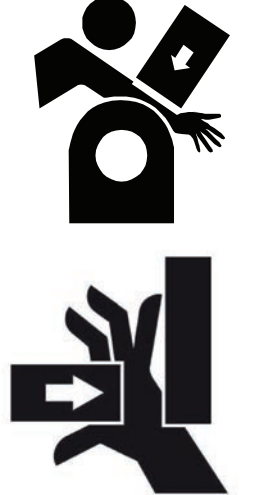

Continues on next page

Symbol	Description
 <p>xx0900000810</p>   <p>3HAC 057068-001</p> <p>xx1500002402</p>	<p>Tip risk when loosening bolts The robot can tip over if the bolts are not securely fastened.</p>
  <p>xx0900000817</p>	<p>Crush Risk of crush injuries.</p>





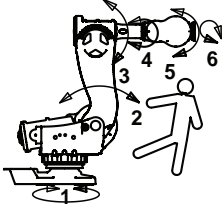
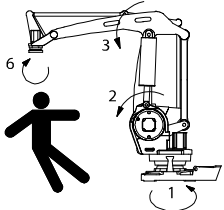
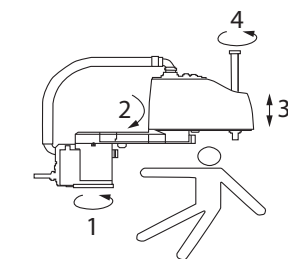

1 Safety

1.2.2 Safety symbols on manipulator labels

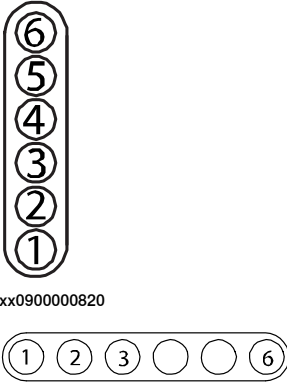
Continued

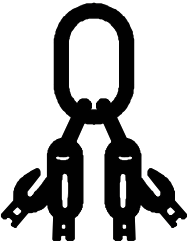
Symbol	Description
 xx0900000818  xx1300001087	Heat Risk of heat that can cause burns. (Both signs are used)
 xx0900000819  xx1000001141  xx1500002616	Moving robot The robot can move unexpectedly.

Continues on next page





Symbol	Description
 <p>xx0900000820</p> <p>xx1000001140</p>	<p>Brake release buttons</p>
 <p>xx0900000821</p>	<p>Lifting bolt</p>
 <p>xx1000001242</p>	<p>Chain sling with shortener</p>
 <p>xx0900000822</p>	<p>Lifting of robot</p>
 <p>xx0900000823</p>	<p>Oil Can be used in combination with prohibition if oil is not allowed.</p>
 <p>xx0900000824</p>	<p>Mechanical stop</p>

Continues on next page

1 Safety

1.2.2 Safety symbols on manipulator labels

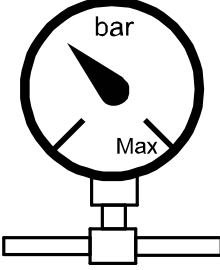
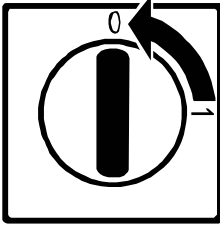
Continued

Symbol	Description
 xx1000001144	No mechanical stop
 xx0900000825	Stored energy Warns that this part contains stored energy. Used in combination with <i>Do not disassemble</i> symbol.
 xx0900000826	Pressure Warns that this part is pressurized. Usually contains additional text with the pressure level.
 xx0900000827	Shut off with handle Use the power switch on the controller.
 xx1400002648	Do not step Warns that stepping on these parts can cause damage to the parts.

1.3 Robot stopping functions

Protective stop and emergency stop

The protective stops and emergency stops are described in the product manual for the controller.

For more information see:

- *Product manual - OmniCore V250XT*
- *Product manual - IRC5*
- *Product manual - IRC5 Panel Mounted Controller*

1 Safety

1.4 Safety during installation and commissioning

1.4 Safety during installation and commissioning

National or regional regulations

The integrator of the robot system is responsible for the safety of the robot system.

The integrator is responsible that the robot system is designed and installed in accordance with the safety requirements set forth in the applicable national and regional standards and regulations.

The integrator of the robot system is required to perform a risk assessment.

Layout

The robot integrated to a robot system shall be designed to allow safe access to all spaces during installation, operation, maintenance, and repair.

If robot movement can be initiated from an external control panel then an emergency stop must also be available.

If the manipulator is delivered with mechanical stops, these can be used for reducing the working space.

A perimeter safeguarding, for example a fence, shall be dimensioned to withstand the following:

- The force of the manipulator.
- The force of the load handled by the robot if dropped or released at maximum speed.
- The maximum possible impact caused by a breaking or malfunctioning rotating tool or other device fitted to the robot.

The maximum TCP speed and the maximum velocity of the robot axes are detailed in the section *Robot motion* in the product specification for the respective manipulator.

Consider exposure to hazards, such as slipping, tripping, and falling.

Hazards due to the working position and posture for a person working with or near the robot shall be considered.

Hazards due to noise emission from the robot needs to be considered.

Consider hazards from other equipment in the robot system, for example, that guards remain active until identified hazards are reduced to an acceptable level.

Allergenic material

See [Environmental information on page 332](#) for specification of allergenic materials in the product, if any.

Securing the robot to the foundation

The robot must be properly fixed to its foundation/support, as described in the respective product manual.

When the robot is installed at a height, hanging, or other than mounted directly on the floor, there will be additional hazards.

Continues on next page

Electrical safety

Incoming mains must be installed to fulfill national regulations.

The power supply wiring to the robot must be sufficiently fused and if necessary, it must be possible to disconnect it manually from the mains power.

The power to the robot must be turned off with the main switch and the mains power disconnected when performing work inside the controller cabinet. Lock and tag shall be considered.

Harnesses between controller and manipulator shall be fixed and protected to avoid tripping and wear.

Wherever possible, power on/off or rebooting the robot controller shall be performed with all persons outside the safeguarded space.



Note

Use a CARBON DIOXIDE (CO₂) extinguisher in the event of a fire in the robot.

Safety devices

The integrator is responsible for that the safety devices necessary to protect people working with the robot system are designed and installed correctly.

When integrating the robot with external devices to a robot system:

- The integrator of the robot system must ensure that emergency stop functions are interlocked in accordance with applicable standards.
- The integrator of the robot system must ensure that safety functions are interlocked in accordance with applicable standards.

Other hazards

A robot may perform unexpected limited movement.



WARNING

Manipulator movements can cause serious injuries on users and may damage equipment.

The risk assessment should also consider other hazards arising from the application, such as, but not limited to:

- Water
- Compressed air
- Hydraulics

End-effector hazards require particular attention for applications which involve close human collaboration with the robot.

Continues on next page

1 Safety

1.4 Safety during installation and commissioning

Continued

Pneumatic or hydraulic related hazards



Note

The pressure in the complete pneumatic or hydraulic systems must be released before service and maintenance.

All components in the robot system that remain pressurized after switching off the power to the robot must be marked with clearly visible drain facilities and a warning sign that indicates the hazard of stored energy.

Loss of pressure in the robot system may cause parts or objects to drop.

Dump valves should be used in case of emergency.

Shot bolts should be used to prevent tools, etc., from falling due to gravity.

All pipes, hoses, and connections have to be inspected regularly for leaks and damage. Damage must be repaired immediately.

Verify the safety functions

Before the robot system is put into operation, verify that the safety functions are working as intended and that any remaining hazards identified in the risk assessment are mitigated to an acceptable level.

1.5 Safety during operation

Automatic operation

Verify the application in the operating mode manual reduced speed, before changing mode to automatic and initiating automatic operation.

Unexpected movement of robot arm



WARNING

Hazards due to the use of brake release devices and/or gravity beneath the manipulator shall be considered.

A robot may perform unexpected limited movement.



WARNING

Manipulator movements can cause serious injuries on users and may damage equipment.

1 Safety

1.6.1 Safety during maintenance and repair

1.6 Safety during maintenance and repair

1.6.1 Safety during maintenance and repair

General

Corrective maintenance must only be carried out by personnel trained on the robot. Maintenance or repair must be done with all electrical, pneumatic, and hydraulic power switched off, that is, no remaining hazards.

Hazards due to stored mechanical energy in the manipulator for the purpose of counterbalancing axes must be considered before maintenance or repair.

Never use the robot as a ladder, which means, do not climb on the controller, manipulator, including motors, or other parts. There are hazards of slipping and falling. The robot might be damaged.

Make sure that there are no loose screws, turnings, or other unexpected parts remaining after work on the robot has been performed.

When the work is completed, verify that the safety functions are working as intended.

Hot surfaces

Surfaces can be hot after running the robot, and touching these may result in burns. Allow the surfaces to cool down before maintenance or repair.

Allergic reaction

Warning	Description	Elimination/Action
 Allergic reaction	When working with lubricants there is a risk of an allergic reaction.	Make sure that protective gear like goggles and gloves are always worn.

Gearbox lubricants (oil or grease)

When handling oil, grease, or other chemical substances the safety information of the respective manufacturer must be observed.









Note

Take special care when handling hot lubricants.

Warning	Description	Elimination/Action
 Hot oil or grease	Changing and draining gearbox oil or grease may require handling hot lubricant heated up to 90 °C.	Make sure that protective gear like goggles and gloves are always worn during this activity.

Continues on next page

Warning	Description	Elimination/Action
 Allergic reaction	When working with lubricants there is a risk of an allergic reaction.	Make sure that protective gear like goggles and gloves are always worn.
 Possible pressure build-up in gearbox	When opening the oil or grease plug, there may be pressure present in the gearbox, causing lubricant to spray from the opening.	Open the plug carefully and keep away from the opening. Do not overfill the gearbox when filling.
 Do not overfill	Overfilling of gearbox lubricant can lead to internal over-pressure inside the gearbox which in turn may: <ul style="list-style-type: none"> • damage seals and gaskets • completely press out seals and gaskets • prevent the robot from moving freely. 	Make sure not to overfill the gearbox when filling it with oil or grease. After filling, verify that the level is correct.
 Do not mix types of oil	Mixing types of oil may cause severe damage to the gearbox.	When filling gearbox oil, do not mix different types of oil unless specified in the instructions. Always use the type of oil specified for the product.
 Oil residues	Oil residues might be present in a drained gearbox and spilled when separating a motor and gearbox during repair.	Make sure that protective gear like goggles/protective visor, gloves and arm protection are always worn during this activity. Put oil absorbent cloth or paper at appropriate locations to catch any oil residues.
 Heat up the oil	Warm oil drains quicker than cold oil.	Run the robot before changing the gearbox oil, if possible.
 Specified amount depends on drained volume	The specified amount of oil or grease is based on the total volume of the gearbox. When changing the lubricant, the amount refilled may differ from the specified amount, depending on how much has previously been drained from the gearbox.	After filling, verify that the level is correct.

Continues on next page

1 Safety

1.6.1 Safety during maintenance and repair

Continued

Warning	Description	Elimination/Action
 Contaminated oil in gearboxes	For lifetime reasons always drain as much oil as possible from the gearbox. The magnetic oil plugs will gather residual metal chips.	

Hazards related to batteries

Under rated conditions, the electrode materials and liquid electrolyte in the batteries are sealed and not exposed to the outside.

There is a hazard in case of abuse (mechanical, thermal, electrical) which leads to the activation of safety valves and/or the rupture of the battery container. As a result under certain circumstances, electrolyte leakage, electrode materials reaction with moisture/water or battery vent/explosion/fire may follow.

Do not short circuit, recharge, puncture, incinerate, crush, immerse, force discharge or expose to temperatures above the declared operating temperature range of the product. Risk of fire or explosion.

Operating temperatures are listed in [Operating conditions, robot on page 44](#).

See safety instructions for the batteries in *Material/product safety data sheet - Battery pack (3HAC043118-001)*.

Unexpected movement of robot arm



WARNING

Hazards due to the use of brake release devices and/or gravity beneath the manipulator shall be considered.

A robot may perform unexpected limited movement.



WARNING

Manipulator movements can cause serious injuries on users and may damage equipment.

Related information

See also the safety information related to installation and operation.

1.6.2 Emergency release of the robot axes

Description

In an emergency situation, the brakes on a robot axis can be released manually by pushing a brake release button.

How to release the brakes is described in the section:

- [Manually releasing the brakes on page 61](#).

The robot may be moved manually on smaller robot models, but larger models may require using an overhead crane or similar equipment.

Increased injury

Before releasing the brakes, make sure that the weight of the manipulator does not result in additional hazards, for example, even more severe injuries on a trapped person.



DANGER

When releasing the holding brakes, the robot axes may move very quickly and sometimes in unexpected ways.

Make sure no personnel is near or beneath the robot.

1 Safety

1.6.3 Brake testing

1.6.3 Brake testing

When to test

During operation, the holding brake of each axis normally wears down. A test can be performed to determine whether the brake can still perform its function.

How to test

The function of the holding brake of each axis motor may be verified as described below:

- 1 Run each axis to a position where the combined weight of the manipulator and any load is maximized (maximum static load).
- 2 Switch the motor to the MOTORS OFF.
- 3 Inspect and verify that the axis maintains its position.

If the manipulator does not change position as the motors are switched off, then the brake function is adequate.



Note

It is recommended to run the service routine *BrakeCheck* as part of the regular maintenance, see the operating manual for the robot controller.

For robots with the option SafeMove, the *Cyclic Brake Check* routine is recommended. See the manual for SafeMove in [References on page 10](#).

1.7 Safety during troubleshooting

General

When troubleshooting requires work with power switched on, special considerations must be taken:

- Safety circuits might be muted or disconnected.
- Electrical parts must be considered as *live*.
- The manipulator can move unexpectedly at any time.



DANGER

Troubleshooting on the controller while powered on must be performed by personnel trained by ABB or by ABB field engineers.



CAUTION

Risk of hot surfaces that can cause burns.

A risk assessment must be done to address both robot and robot system specific hazards.



WARNING

Hazards due to the use of brake release devices and/or gravity beneath the manipulator shall be considered.

A robot may perform unexpected limited movement.



WARNING

Manipulator movements can cause serious injuries on users and may damage equipment.

Related information

See also the safety information related to installation, operation, maintenance, and repair.

1 Safety

1.8 Safety during decommissioning

1.8 Safety during decommissioning

General

See section [Decommissioning on page 331](#).

If the robot is decommissioned for storage, take extra precaution to reset safety devices to delivery status.

Unexpected movement of robot arm



WARNING

Hazards due to the use of brake release devices and/or gravity beneath the manipulator shall be considered.

A robot may perform unexpected limited movement.



WARNING

Manipulator movements can cause serious injuries on users and may damage equipment.

2 Installation and commissioning

2.1 Introduction to installation and commissioning

General

This chapter contains assembly instructions and information for installing the IRB 660 at the working site.

See also the product manual for the robot controller.

The installation must be done by qualified installation personnel in accordance with the safety requirements set forth in the applicable national and regional standards and regulations.

Safety information

Before any installation work is commenced, all safety information must be observed. There are general safety aspects that must be read through, as well as more specific safety information that describes the danger and safety risks when performing the procedures. Read the chapter [Safety on page 19](#) before performing any installation work.



Note

Always connect the IRB 660 and the robot to protective earth and residual current device (RCD) before connecting to power and starting any installation work.

For more information see:

- *Product manual - OmniCore V250XT*
- *Product manual - IRC5*
- *Product manual - IRC5 Panel Mounted Controller*

2 Installation and commissioning

2.2.1 Pre-installation procedure

2.2 Unpacking

2.2.1 Pre-installation procedure

Introduction

This section is intended for use when unpacking and installing the robot for the first time. It also contains information useful during later re-installation of the robot.

Prerequisites for installation personnel

Installation personnel working with an ABB product must:

- be trained by ABB and have the required knowledge of mechanical and electrical installation/maintenance/repair work
- conform to all national and local codes.

Checking the pre-requisites for installation

	Action
1	Make a visual inspection of the packaging and make sure that nothing is damaged.
2	Remove the packaging.
3	Check for any visible transport damage.  Note Stop unpacking and contact ABB if transport damages are found.
4	Clean the unit with a lint-free cloth, if necessary.
5	Make sure that the lifting accessory used (if required) is suitable to handle the weight of the robot as specified in: Weight, robot on page 42
6	If the robot is not installed directly, it must be stored as described in: Storage conditions, robot on page 44
7	Make sure that the expected operating environment of the robot conforms to the specifications as described in: Operating conditions, robot on page 44
8	Before taking the robot to its installation site, make sure that the site conforms to: <ul style="list-style-type: none">• Loads on foundation, robot on page 43• Protection classes, robot on page 45• Requirements, foundation on page 44
9	Before moving the robot, please observe the stability of the robot: Risk of tipping/stability on page 48
10	When these prerequisites are met, the robot can be taken to its installation site as described in section: On-site installation on page 50
11	Install required equipment, if any. <ul style="list-style-type: none">• Safety lamp (option for IRC5) on page 76

Weight, robot

The table shows the weight of the robot.

Robot model	Weight
IRB 660	1750 kg

Continues on next page



Note

The weight does not include tools and other equipment fitted on the robot.

Loads on foundation, robot

The illustration shows the directions of the robots stress forces.

The directions are valid for all floor mounted, suspended and inverted robots.

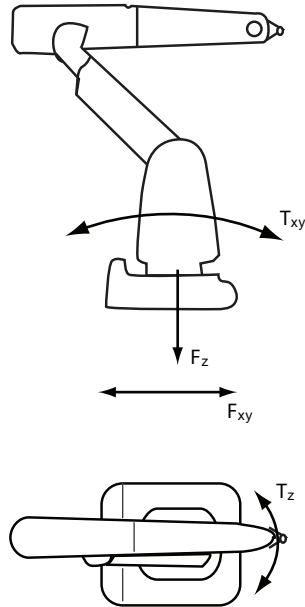

xx1100000521

F_{xy}	Force in any direction in the XY plane
F_z	Force in the Z plane
T_{xy}	Bending torque in any direction in the XY plane
T_z	Bending torque in the Z plane

The table shows the various forces and torques working on the robot during different kinds of operation.



Note

These forces and torques are extreme values that are rarely encountered during operation. The values also never reach their maximum at the same time!



WARNING

The robot installation is restricted to the mounting options given in following load table(s).

Floor mounted

Force	Endurance load (in operation)	Max. load (emergency stop)
Force xy	± 8.0 kN	± 11.7 kN

Continues on next page

2 Installation and commissioning

2.2.1 Pre-installation procedure

Continued

Force	Endurance load (in operation)	Max. load (emergency stop)
Force z	18.0 ±4.9 kN	18.0 ±8.2 kN
Torque xy	± 23.2 kNm	± 31.2 kNm
Torque z	± 7.7 kNm	± 9.9 kNm

Requirements, foundation

The table shows the requirements for the foundation where the weight of the installed robot is included:

Requirement	Value	Note
Flatness of foundation surface	0.3 mm	Flat foundations give better repeatability of the resolver calibration compared to original settings on delivery from ABB. The value for levelness aims at the circumstance of the anchoring points in the robot base.
Maximum tilt	5°	
Minimum resonance frequency	22 Hz  Note It may affect the manipulator lifetime to have a lower resonance frequency than recommended.	The value is recommended for optimal performance. Due to foundation stiffness, consider robot mass including equipment. ⁱ For information about compensating for foundation flexibility, see the application manual of the controller software, section <i>Motion Process Mode</i> .

ⁱ The minimum resonance frequency given should be interpreted as the frequency of the robot mass/inertia, robot assumed stiff, when a foundation translational/torsional elasticity is added, i.e., the stiffness of the pedestal where the robot is mounted. The minimum resonance frequency should not be interpreted as the resonance frequency of the building, floor etc. For example, if the equivalent mass of the floor is very high, it will not affect robot movement, even if the frequency is well below the stated frequency. The robot should be mounted as rigid as possible to the floor.

Disturbances from other machinery will affect the robot and the tool accuracy. The robot has resonance frequencies in the region 10 – 20 Hz and disturbances in this region will be amplified, although somewhat damped by the servo control. This might be a problem, depending on the requirements from the applications. If this is a problem, the robot needs to be isolated from the environment.

Storage conditions, robot

The table shows the allowed storage conditions for the robot:

Parameter	Value
Minimum ambient temperature	-25° C
Maximum ambient temperature	+55° C
Maximum ambient temperature (less than 24 hrs)	+70° C
Maximum ambient humidity	95% at constant temperature (gaseous only)

Operating conditions, robot

The table shows the allowed operating conditions for the robot:

Parameter	Value
Minimum ambient temperature	0° C ⁱ

Continues on next page

Parameter	Value
Maximum ambient temperature	+50° C
Maximum ambient humidity	95% at constant temperature

ⁱ During cold start (0° C - 5° C), see [Start of robot in cold environments on page 83](#).

Protection classes, robot

The table shows the available protection types of the robot, with the corresponding protection class.

Protection type	Protection class ¹
Manipulator, protection type Standard	IP 67

2 Installation and commissioning

2.2.2 Working range and type of motion

2.2.2 Working range and type of motion

Working range

The following figures show the working ranges of the robot variants. The extreme positions of the robot arm are specified at the wrist center (dimensions in mm).

IRB 660 - 180/3.15 and IRB 660 - 250/3.15

The illustration below shows the unrestricted working range of IRB 660 - 180/3.15 and IRB 660 - 250/3.15.

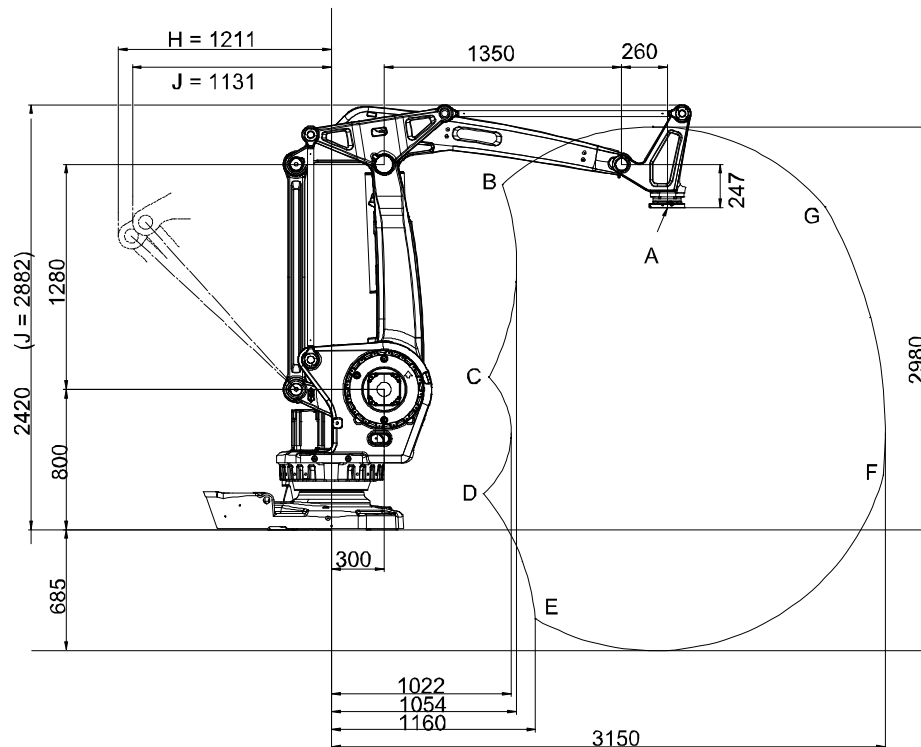

xx0500002274

H	Mechanical stop
J	Max working range

	Position x (mm)	Position z (mm)	Angle axis 2 (degrees)	Angle axis 3 (degrees)
A	1910	1833	0	0
B	972	1966	-42	-20
C	895	870	-42	28
D	866	207	50	120
E	1160	-505	85	120
F	3139	315	85	15
G	2809	1837	50	-20

Continues on next page

Type of motion

The table below specifies the types and ranges of the robot motion in every axis.

Axis	Type of motion	Range of motion
1	Rotation motion	-180° to +180°
2	Arm motion	-42° to +85°
3	Arm motion	-20° to +120°
2-3	Arm motion	20° to 160°
6	Turn motion	-300° to +300°

2 Installation and commissioning

2.2.3 Risk of tipping/stability

2.2.3 Risk of tipping/stability

Risk of tipping

Do not change the robot position before securing it to the foundation.
The shipping position is the most stable position.

Shipping and transportation position

This figure shows the robot in its shipping position and transportation position.

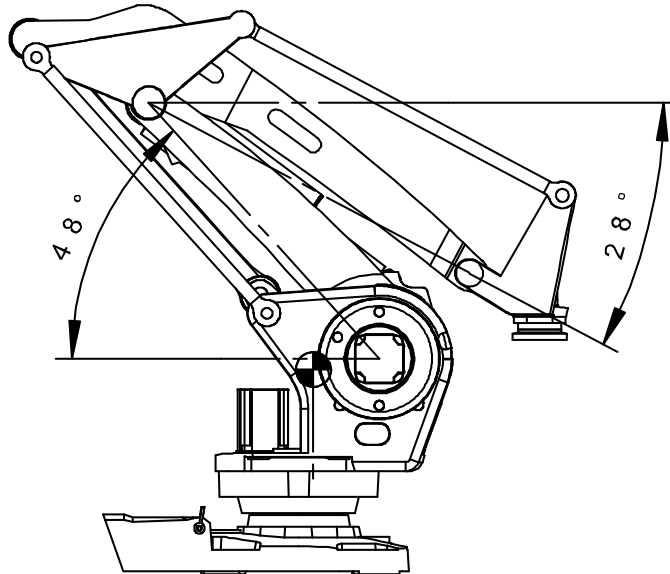

xx0500002275



WARNING

The robot will be mechanically unstable if not properly secured to the foundation.

2.2.4 The unit is sensitive to ESD

Description

ESD (electrostatic discharge) is the transfer of electrical static charge between two bodies at different potentials, either through direct contact or through an induced electrical field. When handling parts or their containers, personnel not grounded may potentially transfer high static charges. This discharge may destroy sensitive electronics.

Safe handling

Use one of the following alternatives:

- Use a wrist strap.

Wrist straps must be tested frequently to ensure that they are not damaged and are operating correctly.

- Use an ESD protective floor mat.

The mat must be grounded through a current-limiting resistor.

- Use a dissipative table mat.

The mat should provide a controlled discharge of static voltages and must be grounded.

2 Installation and commissioning

2.3.1 Lifting robot with fork lift

2.3 On-site installation

2.3.1 Lifting robot with fork lift

General

The robot may be moved using a fork lift, provided that available special aids are used.

This section describes how to attach the fork lift equipment to the robot.

Attachment points on robot

The attachment points for the fork lift equipment are shown in this figure.

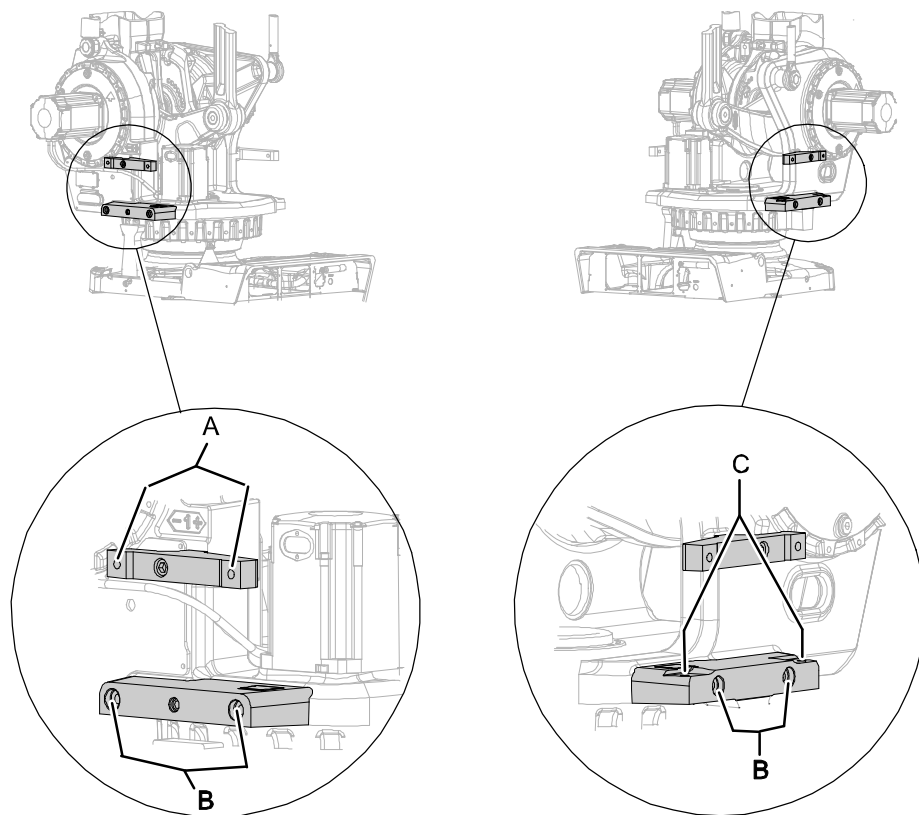

xx0500002276

A	Attachment points on adapter and horizontal attachment screws
B	Attachment points, horizontal attachment screws
C	Attachment points, vertical attachment screws

Required equipment

Equipment, etc.	Art. no.	Note
Fork lift set, incl. all required hardware	3HAC023044-001	See figure <i>Fork lift set, 3HAC023044-001 on page 51</i> .
Standard toolkit	-	Content is defined in section <i>Standard tools on page 346</i> .

Continues on next page

Fork lift set, 3HAC023044-001

The fork lift set 3HAC023044-001, is fitted to the robot as shown in the figure below.

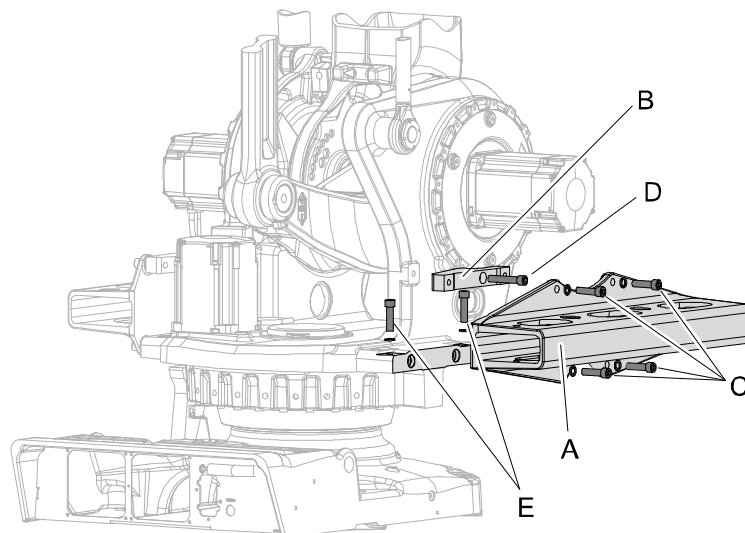
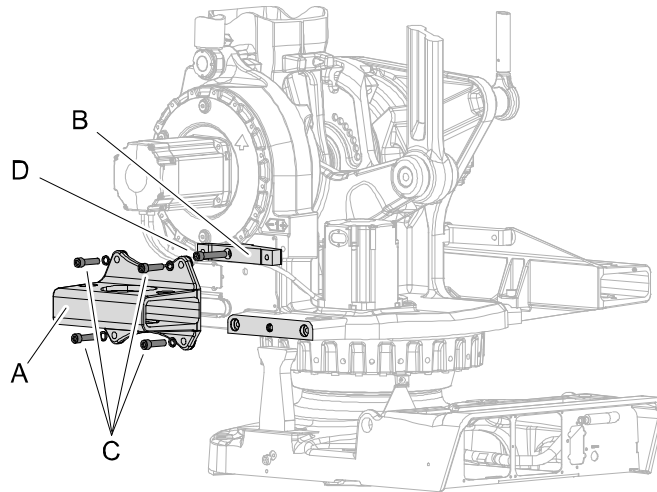

xx0500002277

A	Fork lift pocket (2 pcs, one long and one short)
B	Adapter (2 pcs)
C	Horizontal attachment screws (4 pcs / fork lift pocket)
D	Attachment screw for adapter (1 pc / adapter)
E	Vertical attachment screws (2 pcs)

Continues on next page

2 Installation and commissioning

2.3.1 Lifting robot with fork lift

Continued

Lifting robot with fork lift

This section details how to secure the fork lift set to the robot in order to lift and move the robot using the fork lift **ONLY!**

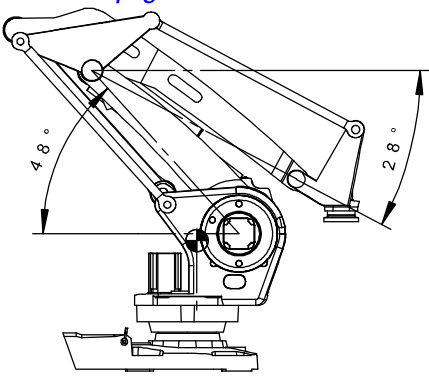
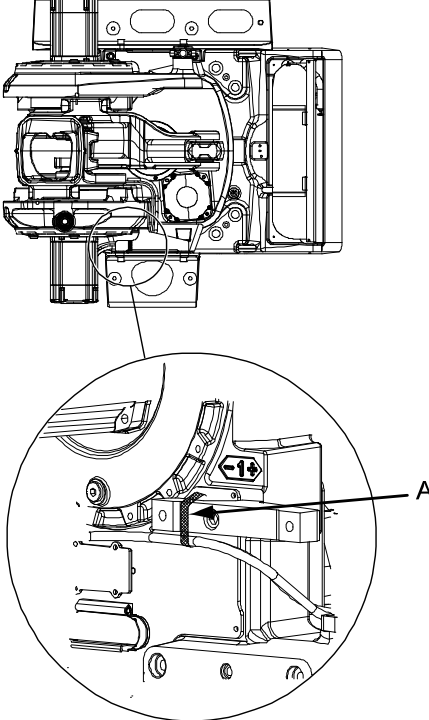

	Action	Note
1	Position the robot as shown in the figure to the right!	<p>Release the brakes if required as detailed in section Manually releasing the brakes on page 61.</p>  <p>xx0500002275</p>
2	Fit the two adapters to the robot and secure.	<p>Attachment points are shown in figure Attachment points on robot on page 50. Attachment screws, 2 pcs, M16 x 90. Tightening torque: 270 Nm.</p>
3	Strap up axis 2 motor cable on the adapter.	 <p>xx0500002278</p> <ul style="list-style-type: none">A: Strap, velcro

Continues on next page

2 Installation and commissioning

2.3.1 Lifting robot with fork lift

Continued

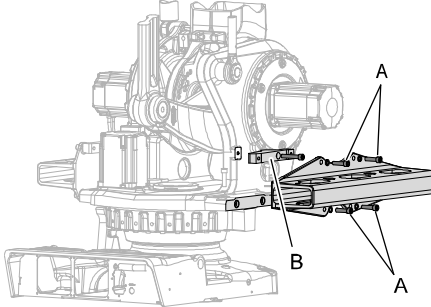
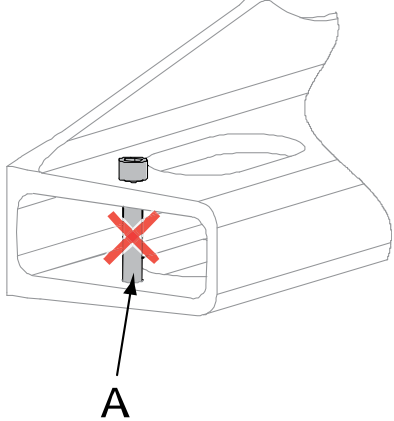



	Action	Note
4	 CAUTION The fork lift pocket weighs 60 kg!	
5	<p>Secure the longer <i>fork lift pocket</i> to the adapter and frame with four of the horizontal <i>attachment screws</i> and <i>washers</i>.</p>  Note The screws, which are attached horizontally and vertically, are identical. However, they are tightened with different torque!	<p>Always use original screws (or replacements of equivalent quality: M16, quality 12.9)!</p> <p>Attachment points on the robot are shown in figure Attachment points on robot on page 50.</p>  <p>xx0500002279</p> <p>A Horizontal attachment screws, 4 pcs, M16 x 60. Tightening torque: 60 Nm.</p> <p>B Adapter</p>
6	<p>Make sure the securing screw is removed from the fork lift pocket! It is only used for robot model IRB 6650S.</p>	 <p>xx0700000655</p> <p>A Securing screw</p>

Continues on next page

2 Installation and commissioning

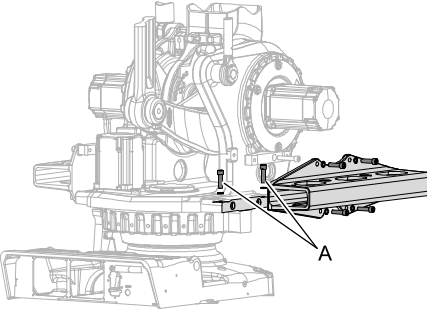
2.3.1 Lifting robot with fork lift

Continued

	Action	Note
7	<p>Secure fork lift pocket to robot with two <i>vertical attachment screws</i> and washers.</p> <p> Note</p> <p>Vertically and the horizontally attached screws are identical, but tightened with different torques!</p>	 <p>xx0500002284</p> <p>A Vertical attachment screws, 2 pcs, M16x60. Tightening torque: 270 Nm.</p> <p>Always use original screws (or replacements of equivalent quality: M16, quality 12.9)!</p> <p>Attachment points on robot are shown in figure Attachment points on robot on page 50.</p>
8	<p> CAUTION</p> <p>The fork lift pocket weighs 22 kg!</p>	
9	<p>Secure the shorter fork lift pocket on the other side of the robot with the four remaining <i>horizontal attachment screws</i>.</p>	<p>4 pcs, M16x60. Tightening torque: 60 Nm.</p> <p>Always use original screws (or replacements of equivalent quality: M16, quality 12.9)!</p> <p>Attachment points on robot are shown in figure Attachment points on robot on page 50.</p>
10	<p>Double-check that pockets are properly secured to the robot! Insert fork lift forks into the pockets.</p>	
11	<p> CAUTION</p> <p>The IRB 660 robot weighs 1750 kg. All lifting accessories used must be sized accordingly!</p>	
12	<p>Carefully lift the robot and move it to its installation site.</p>	
13	<p> WARNING</p> <p>Personnel must not, under any circumstances, be present under the suspended load!</p>	
	<p>Refit the cooling fan to the motor, if any.</p>	

2.3.2 Lifting robot with roundslings



General

The robot can be lifted with roundslings according to this section.

Sling specification

Sling type	Qty	Lifting capacity	Length / Note
Chain sling with shortener	4 pcs	4 000 kg	0.605 m 0.8 m 1.0 m (2 pcs)
Roundsling, robot	4 pcs	2 000 kg	2 m
Roundsling, upper arm	1 pc	2 000 kg	1 m 2 m Secures against rotation.

Lifting with roundslings

	Action	Note
1	Position robot in a secure transport position.	
2	Attach roundslings to robot according to figure Attachment points on page 56 .	
3	 CAUTION The IRB 660 robot weighs 1750 kg. All lifting accessories used must be sized accordingly!	
4	 WARNING Personnel must not, under any circumstances, be present under the suspended load!	

Continues on next page

2 Installation and commissioning

2.3.2 Lifting robot with roundslings

Continued

Attachment points

This figure shows how to attach the roundslings to the robot.

The illustration is similar with the label attached to the robot's frame.

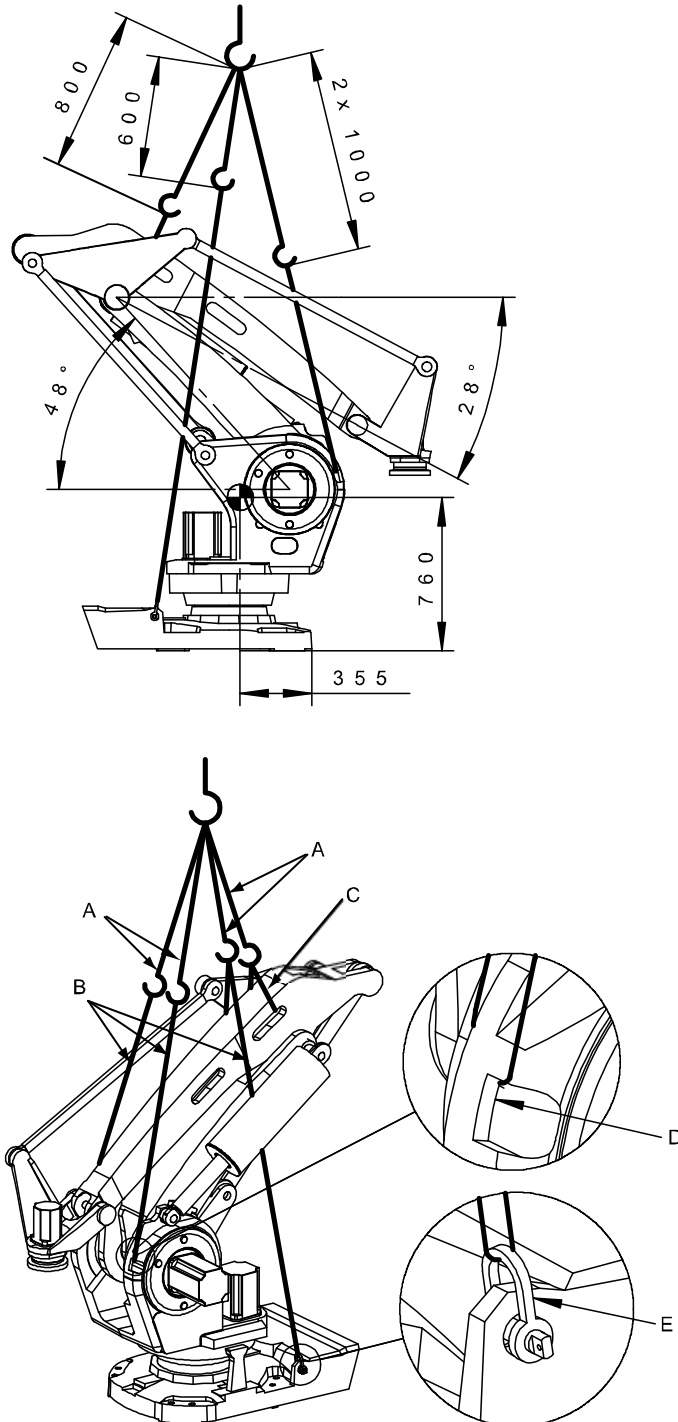

xx0500002285

A	Chain sling with shortener
B	Roundsling, robot
C	Roundsling, upper arm. Used to secure against rotation.

Continues on next page

2 Installation and commissioning

2.3.2 Lifting robot with roundslings

Continued

D	<i>Note!</i> No sharp edges!
E	Shackle

2 Installation and commissioning

2.3.3 Lifting robot with lifting accessory (recommended lifting method)

2.3.3 Lifting robot with lifting accessory (recommended lifting method)

General

This section contains a general overview of how to lift the complete robot using special lifting accessory.

Illustration, lifting accessory

The following figure shows the principle for how to use and lift the entire robot with lifting accessory. For a more detailed instruction, see the user instructions enclosed with the accessory.



Note

The user manual may be out of date. The latest revision is available for download via myABB Business Portal, www.abb.com/myABB.

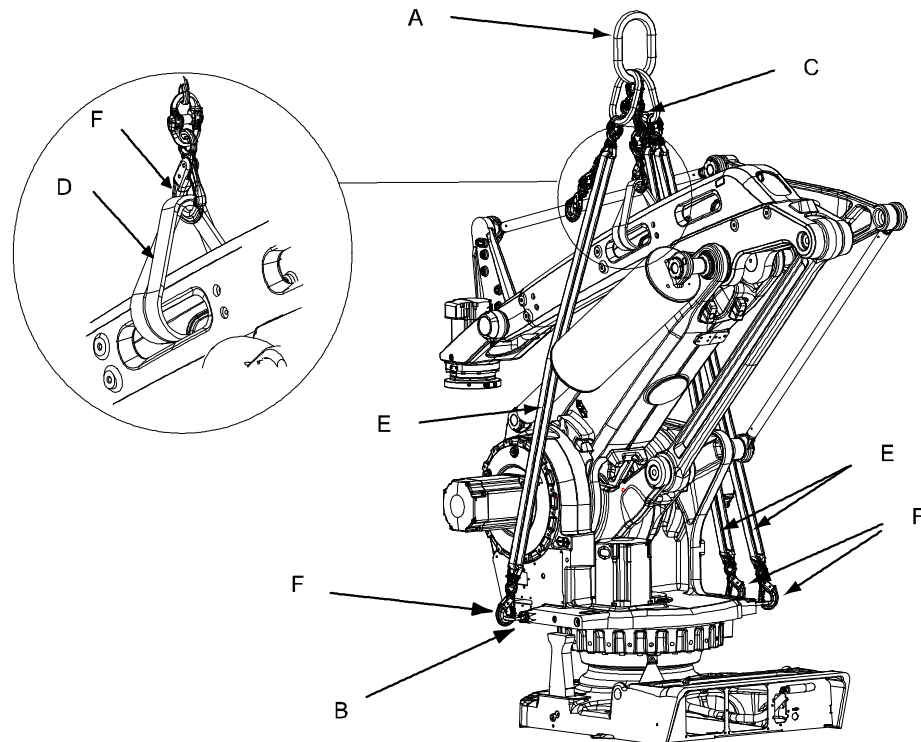

xx0500002460

A	Eye for lifting accessory
B	Swivelling lifting eyes, 3 pcs
C	Chain
D	Lifting sling, short. Secures against rotation.
E	Lifting slings, long
F	Hook

Continues on next page

Required equipment

Equipment	Article number	Note
Lifting accessory, robot	3HAC15607-1	Includes user instructions 3HAC15971-2

Slings attached directly onto robot

This section details how to lift and move the robot using lifting slings when these are attached directly onto the robot.



Note

Please refer to the enclosed user instruction for instruction how to place the manipulator in an correct position. Attempting to lift a manipulator in any other position may result in the robot tipping over, causing severe damage or injury!

	Action	Note
1	Run the overhead crane to a position above the robot.	
2	Position the robot as detailed in enclosed instruction!	Article number is specified in Required equipment on page 59 . Release the brakes, if required, as detailed in section Manually releasing the brakes on page 61 .
3	<h4>Note</h4> <p>If the robot is equipped with forklift pockets, it is necessary to remove these in order to reach the lower holes in the frame. These are used to attach the <i>hooks</i> of the lifting slings.</p>	Shown in the figure Illustration, lifting accessory on page 58 .
4	<p>Fit the <i>lifting accessory</i> to the robot as described in the enclosed instruction! Go to the user instructions enclosed with the lifting accessory.</p> <h4>DANGER</h4> <p>Handling the tool incorrectly will cause serious injury. Read and follow enclosed user instructions for the tool.</p>	Article number is specified in Required equipment on page 59 .
5	<h4>CAUTION</h4> <p>The IRB 660 robot weighs 1750 kg. All lifting accessories used must be sized accordingly!</p>	
6	<h4>WARNING</h4> <p>Personnel must not, under any circumstances, be present under the suspended load!</p>	

Continues on next page

2 Installation and commissioning

2.3.3 Lifting robot with lifting accessory (recommended lifting method)

Continued

	Action	Note
7	Raise overhead crane to lift the robot.	Make sure all hooks and attachments maintain their correct positions while lifting the robot! Always move the robot at very low speeds, making sure it does not tip.

2.3.4 Manually releasing the brakes

Introduction to manually releasing the brakes

This section describes how to release the holding brakes for the motors of each axis.

Location of brake release unit

The internal brake release unit is located as shown in the figure.



Note

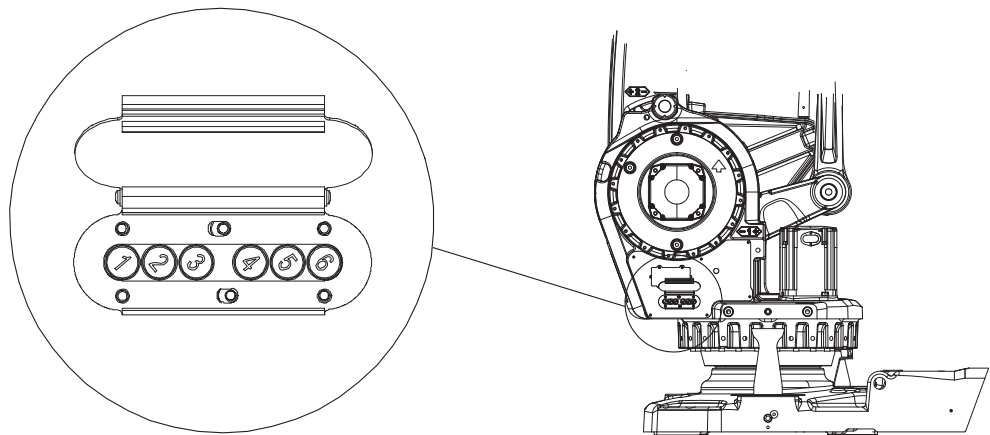

Axes 4 and 5 do not exist!



xx0500002286

Releasing the brakes

This procedure details how to release the holding brakes when the robot is equipped with an internal brake release unit.

	Action	Note
1	<p>The internal brake release unit is equipped with buttons for controlling the axes brakes. The buttons are numbered according to the numbers of the axes.</p> <p> Note</p> <p>Axes 4 and 5 do not exist!</p> <p>If the robot is not connected to the controller, power must be supplied to the connector R1.MP according to the section Supplying power to connector R1.MP on page 62.</p>	<p>Buttons are shown in figure Location of brake release unit on page 61.</p>
2	<p> DANGER</p> <p>When releasing the holding brakes, the robot axes may move very quickly and sometimes in unexpected ways.</p> <p>Make sure no personnel is near or beneath the robot.</p>	

Continues on next page

2 Installation and commissioning

2.3.4 Manually releasing the brakes

Continued

	Action	Note
3	Release the holding brake on a particular robot axis by pressing the corresponding button on the internal brake release unit. The brake will function again as soon as the button is released.	

Supplying power to connector R1.MP

If the robot is not connected to the controller, power must be supplied to connector R1.MP on the robot, in order to enable the brake release buttons.

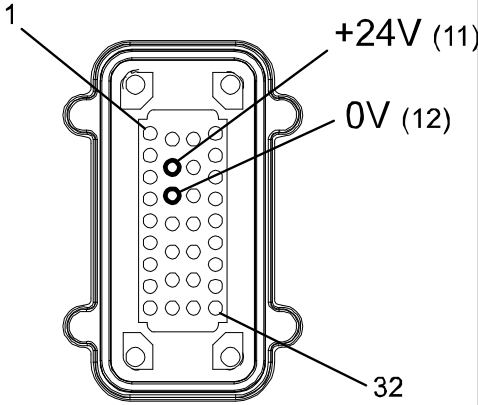
	Action	Note
1	 DANGER Incorrect connections, such as supplying power to the wrong pin, may cause all brakes to be released simultaneously!	
2	Supply 0V on pin 12 and 24V on pin 11.	 xx0600002937

2.3.5 Lifting the base plate

Required equipment

Equipment	Article number	Note
Lifting eye, M16	3HAC14457-4	3 pcs
Lifting slings		Length: approx. 2 m

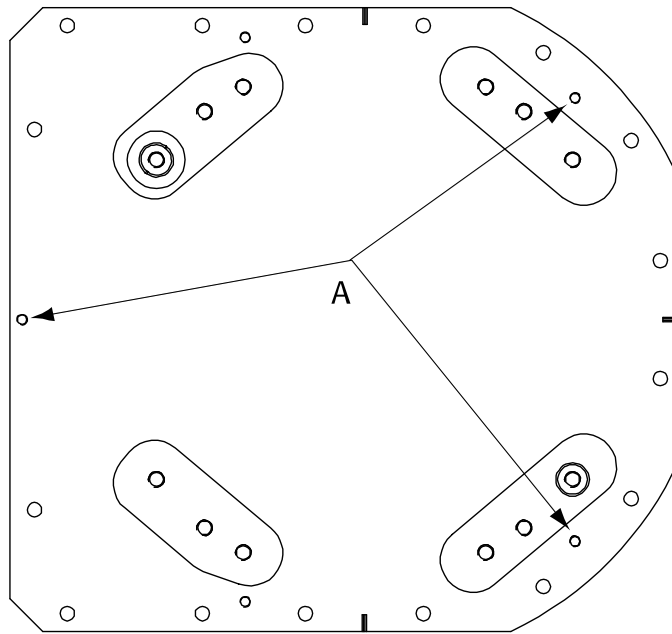

Hole configuration



xx020000096

A	Attachment holes for lifting eyes (x3)
---	--

Lifting, base plate

	Action	Note
1	 CAUTION The base plate weighs 353 kg. All lifting accessories used must be sized accordingly.	
2	Fit lifting eyes in specified holes.	Shown in figure Hole configuration on page 63 .
3	Fit lifting slings to the eyes and to the lifting accessory.  CAUTION Lift and move the base plate very slowly. If the base plate starts to swing it is a risk for injuries or damage.	

2 Installation and commissioning

2.3.6 Securing the base plate

2.3.6 Securing the base plate

Base plate, dimensions

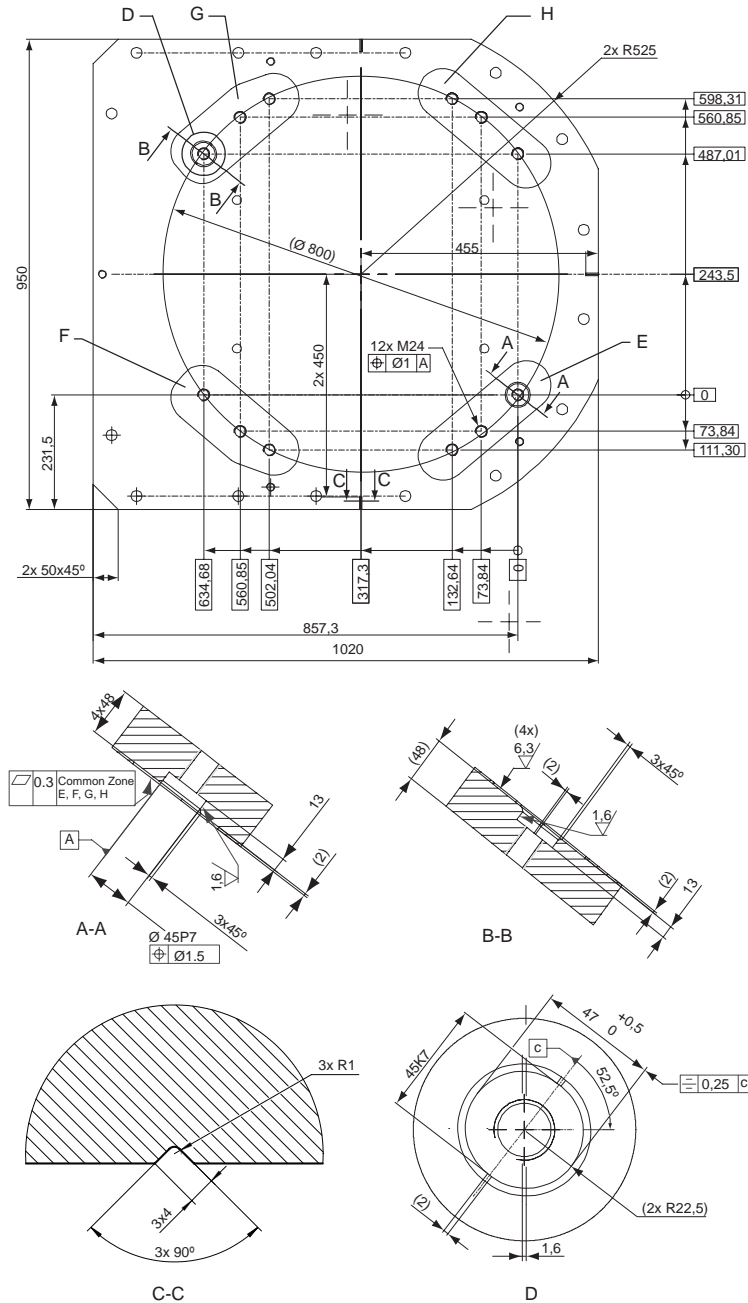

E, F, G, H	Common tolerance zone (accuracy all over the base plate from one contact surface to the other)
------------	--

Continues on next page

2 Installation and commissioning

2.3.6 Securing the base plate

Continued

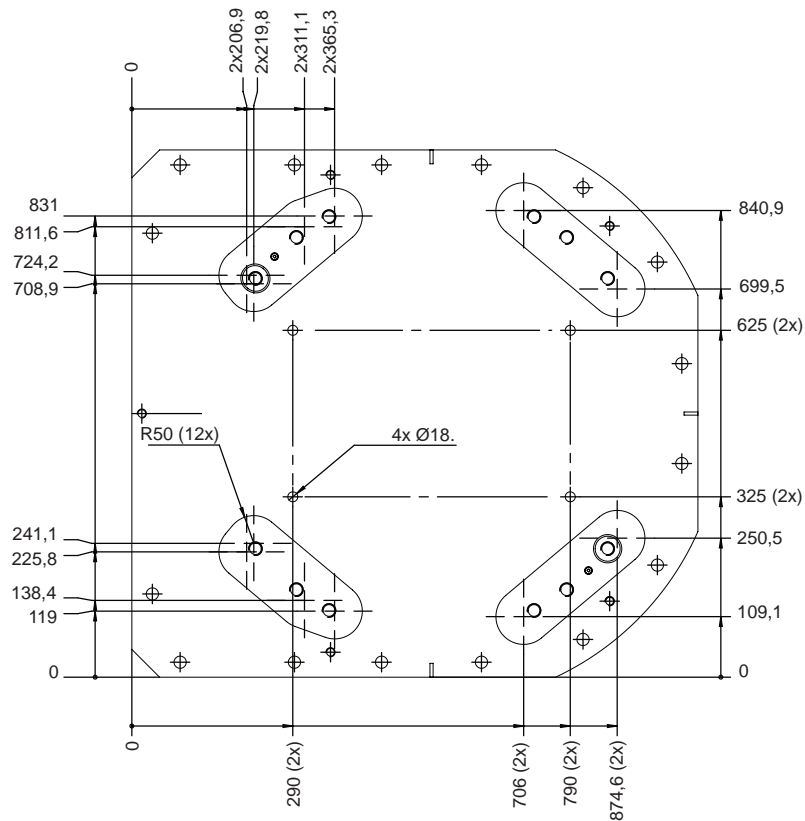
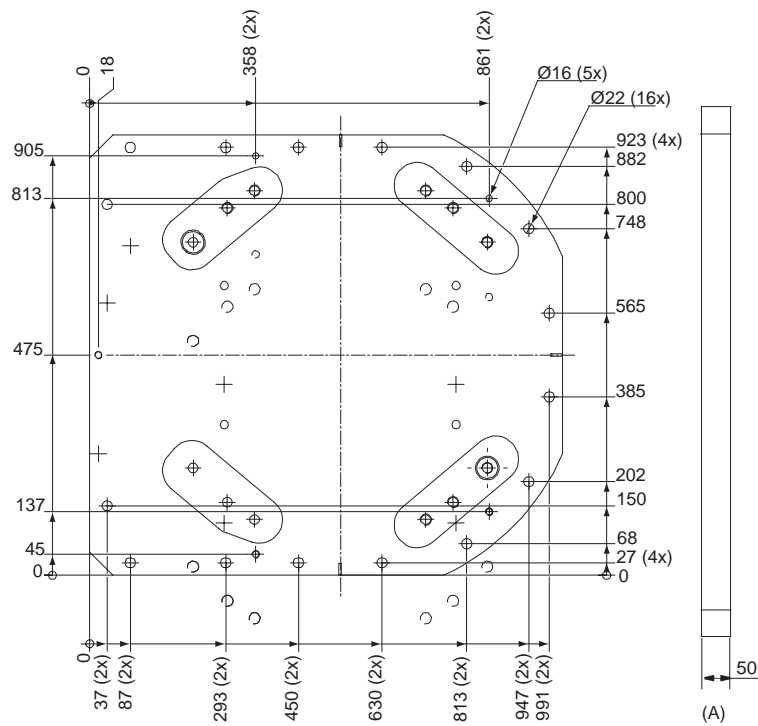

xx1000001054

▣

-	Four holes for alternative clamping, 4x Ø18
A	Color: RAL 9005. Thickness: 80-100 µm

Continues on next page

2 Installation and commissioning

2.3.6 Securing the base plate

Continued

Base plate, orienting grooves and leveling bolts

The illustration below shows the orienting grooves and attachment holes for leveling bolts in the base plate.

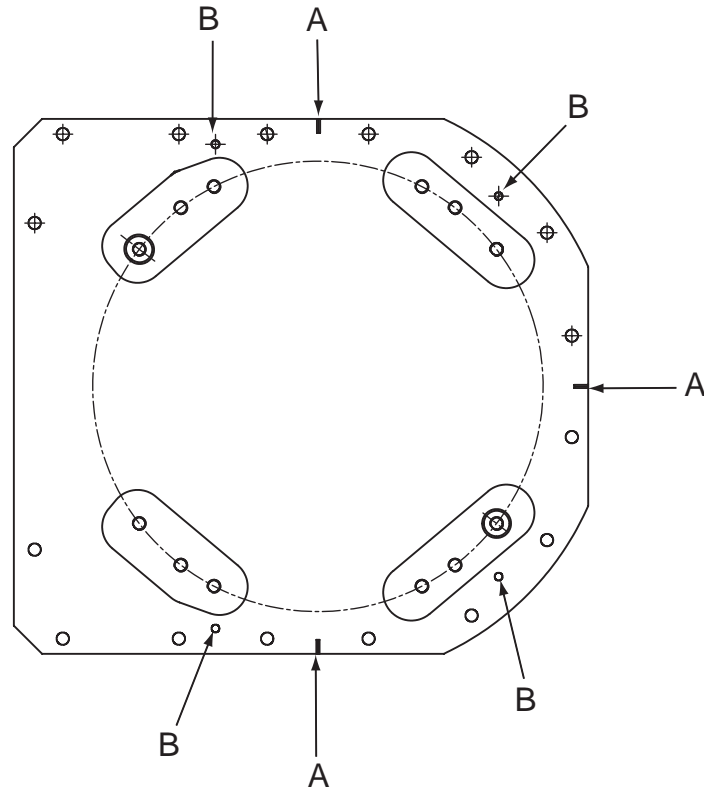

xx150000312

A	Orienting grooves (3 pcs)
B	Levelling bolts, attachment holes (4 pcs)

Continues on next page

Base plate, guide sleeve holes

The illustration below shows the orienting grooves and guide sleeve holes in the base plate.

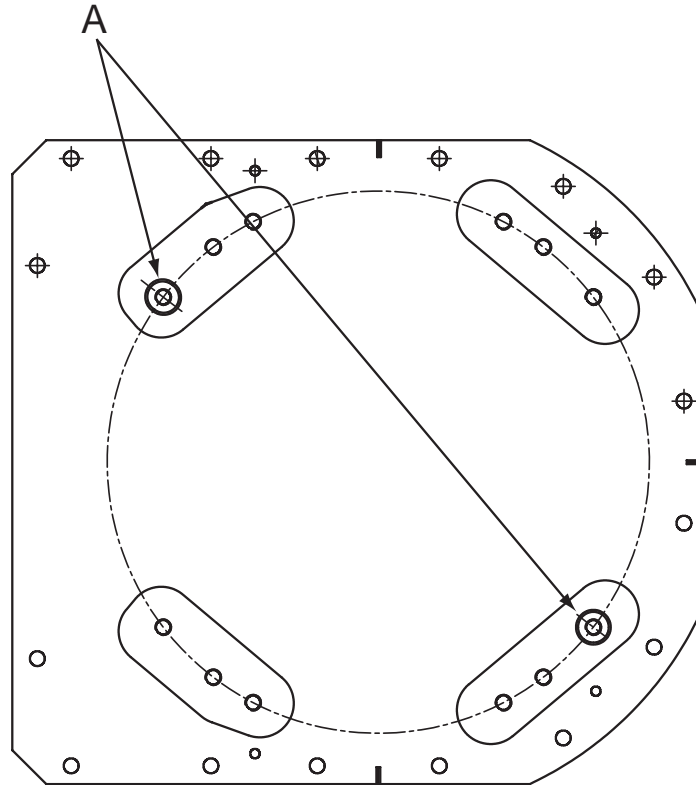

xx030000045

A	Guide sleeve holes (2 pcs)
---	----------------------------

Required equipment

Equipment	Article number	Note
Base plate	3HAC12937-9	Includes <ul style="list-style-type: none"> • guide sleeves, 3HAC12937-3 • levelling screws, 9ADA120-79 • attachment screws and washers for securing the robot to the base plate.
Standard toolkit	-	Content is defined in section Standard tools on page 346 .
Other tools and procedures may be required. See references to these procedures in the step-by-step instructions below.		These procedures include references to the tools required.

Base plate

This section details how to secure the base plate to the foundation.

	Action	Note
1	Make sure the foundation is levelled.	

Continues on next page

2 Installation and commissioning

2.3.6 Securing the base plate

Continued

	Action	Note
2	 CAUTION The base plate weighs 353 kg! All lifting equipment used must be sized accordingly!	
3	Position base plate in relation to the robot work location using the grooves in the base plate.	Shown in figure Base plate, orienting grooves and leveling bolts on page 66 .
4	Lift the base plate to its mounting position.	Detailed in section Lifting the base plate on page 63 .
5	Use the base plate as a template and drill attachment holes as required by the selected bolt dimension.	Attachment holes: 16 pcs.
6	Fit the base plate and use the levelling bolts to level the base plate.	Shown in figure Base plate, orienting grooves and leveling bolts on page 66 .
7	If required, fit strips of sheet metal underneath the base plate to fill any gaps.	
8	Secure the base plate to the foundation with screws and sleeves.	
9	Recheck the four contact surfaces on the base plate to make sure the base plate is levelled and flat. If it is not, use pieces of sheet metal or similar to bring the base plate to a levelled position.	Maximum allowed deviation all over the base plate, from one contact surface to the other: 0.3 mm.

2.3.7 Orienting and securing the robot

General

This section details how to orient and secure the robot to the base plate in order to run the robot safely.

Illustration, robot fitted to base plate

This illustration shows the robot base fitted to the base plate.

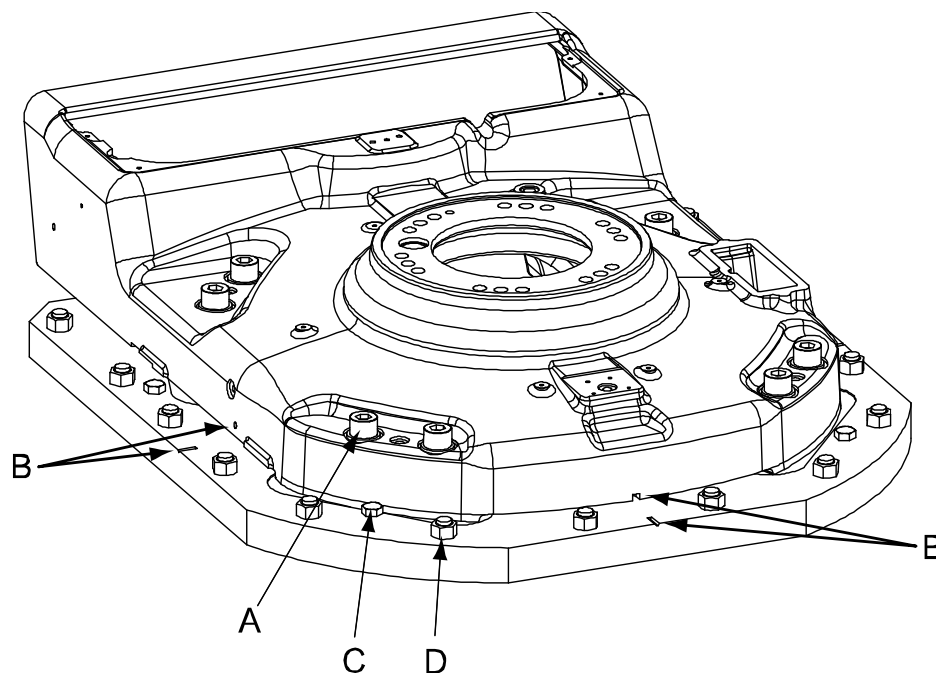

xx0300000566

A	Robot attachment bolts and washers, 8 pcs (M24 x 140)
B	Orienting grooves in the robot base and in the base plate
C	Levelling screws
D	Base plate attachment screws

Attachment screws

The table below specifies the type of securing screws and washers to be used for securing the robot to the base plate/foundation.

Suitable screws, lightly lubricated:	M24 x 140
Quality:	Quality 8.8
Suitable washer:	Thickness: 4 mm Outer diameter: 44 mm Inner diameter: 25 mm
Tightening torque:	725 Nm

Continues on next page



2 Installation and commissioning

2.3.7 Orienting and securing the robot

Continued

Securing the robot

Use this procedure to secure robot to base plate after fitting plate to the foundation.

	Action	Note
1	Lift the robot.	See section Lifting robot with lifting accessory (recommended lifting method) on page 58 . See section Lifting robot with round-slings on page 55 .
2	Move robot to the vicinity of its installation location.	
3	Fit two guide sleeves to the <i>guide sleeve holes</i> in the base plate.	Shown in figure Base plate, guide sleeve holes on page 67 .  Note One of the guide sleeve holes is elongated!
4	Guide the robot gently using two M24 screws while lowering it into its mounting position.	Make sure the robot base is correctly fitted onto the guide sleeves!
5	Fit the <i>bolts and washers</i> in the base attachment holes.	Specified in Attachment screws on page 69 . Shown in figure Illustration, robot fitted to base plate on page 69 .  Note Lightly lubricate screws before assembly!
6	Tighten bolts in a criss-cross pattern to ensure that the base is not distorted.	

Continues on next page

Hole configuration, base

This illustration shows the hole configuration used when securing the robot.

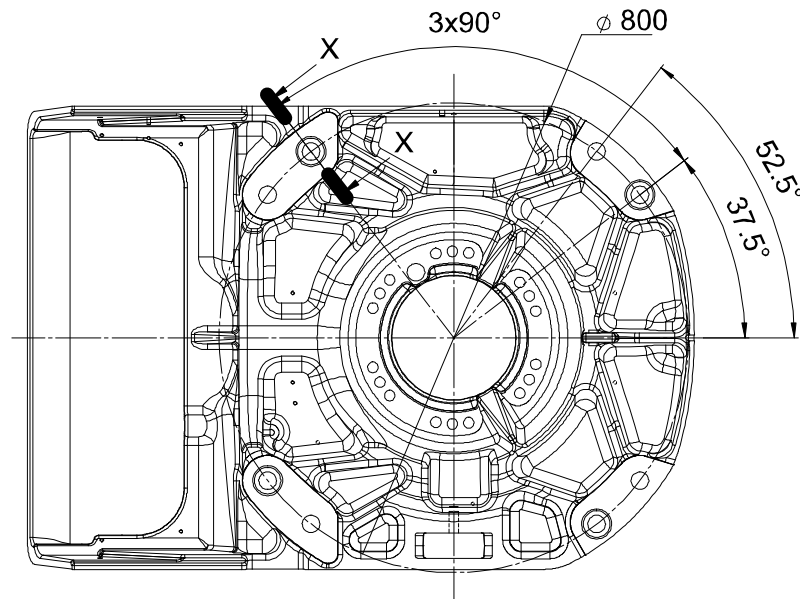

xx0600002628

Cross section, guide sleeve hole

This illustration shows the cross section of the guide sleeve holes.

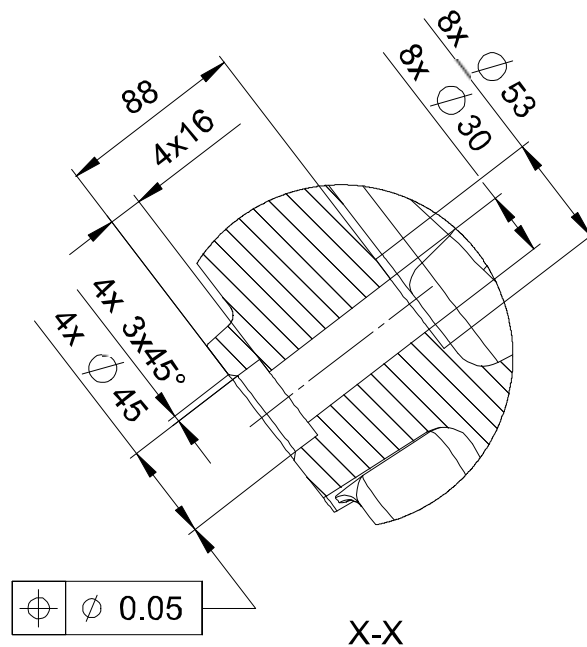

xx0600002629

2 Installation and commissioning

2.3.8 Fitting equipment on robot

2.3.8 Fitting equipment on robot

General

The robot features mounting holes for additional equipment.

Access to any of the following mounting holes may be obstructed by any additional cabling, equipment, etc., fitted by the robot user. Make sure the required mounting holes are accessible when planning the robot cell.



Note

All equipment and cables used on the robot, must be designed and fitted not to damage the robot and/or its parts.



Note

No extra equipment may be fitted on the lower arm of the robot.

Illustration, fitting of extra equipment on upper arm

The illustration below shows the mounting holes available for fitting extra equipment on the upper arm.

For fitting of extra vacuum hose all holes shall be used (6 pcs). These holes can only be used for extra vacuum hose!

The max. weight of the vacuum hose and fastening device on the upper arm, is calculated to 10 kg.

Max. extra weight on the upper arm:

- IRB 660 - 180/3.15 = 35 kg
- IRB 660 - 250/3.15 = 35 kg

Note! The weight of the extra equipment on the upper arm must be deducted from the maximal handling capacity.

Continues on next page

2 Installation and commissioning

2.3.8 Fitting equipment on robot

Continued

Example: If 35 extra kg is put on the upper arm, this means that the robot only can handle $180 - 35 = 145$ kg or $250 - 35 = 215$ kg (depending on model).

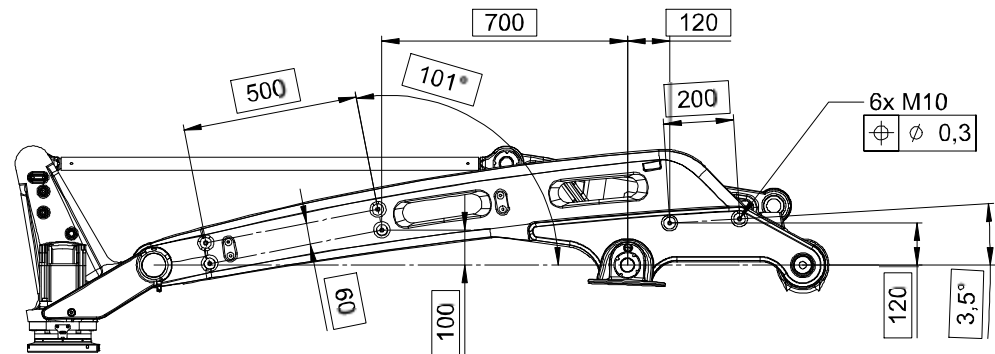

xx0500002289

A	Fitting holes, M10 (2 pcs)
B	Fitting holes, M10 (2 pcs)
C	Fitting holes, M10 (2 pcs)

Illustration, fitting of extra equipment on frame

The illustration below shows the mounting holes available for fitting extra equipment on the frame.

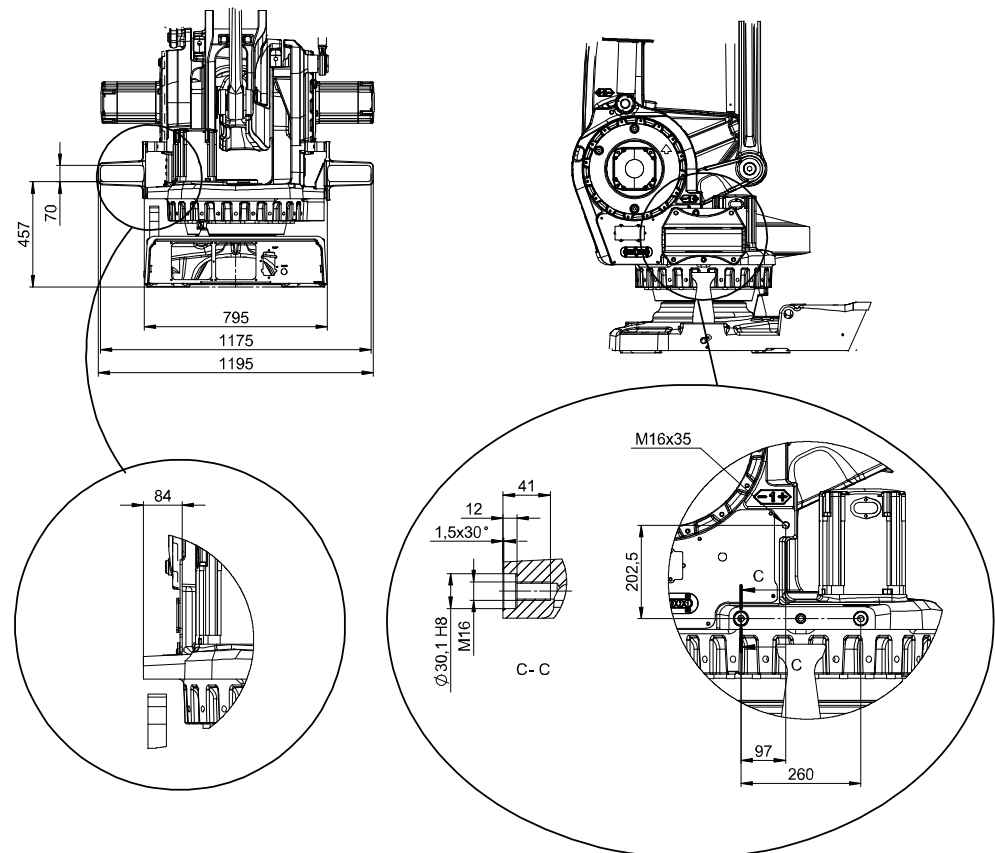

xx0500002505

Continues on next page

2 Installation and commissioning

2.3.8 Fitting equipment on robot

Continued

Illustration, fitting on turning disk

The illustration below shows the mounting holes available for fitting equipment on the turning disk.

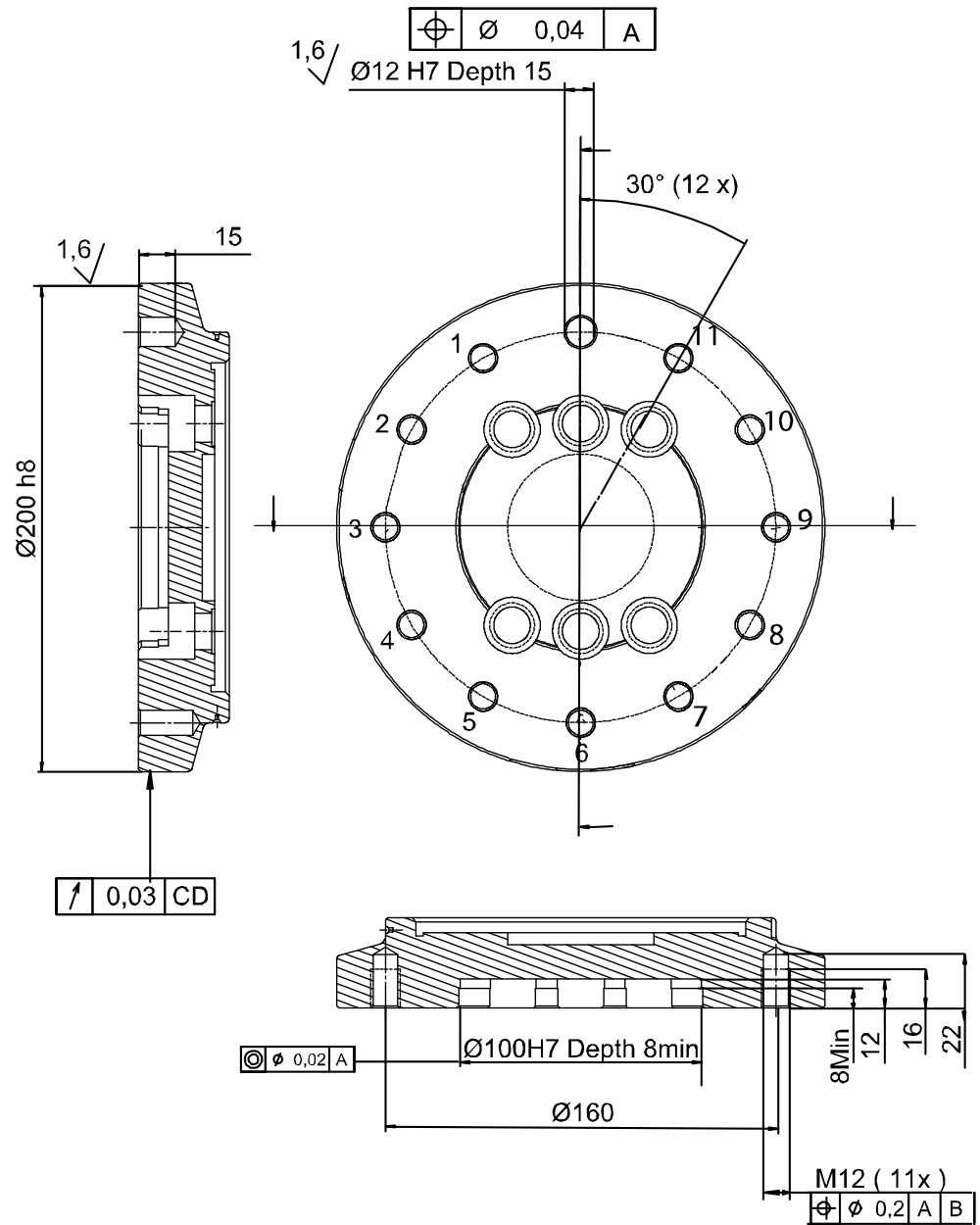

xx0500002292

-	Mounting flange.
---	------------------

Continues on next page

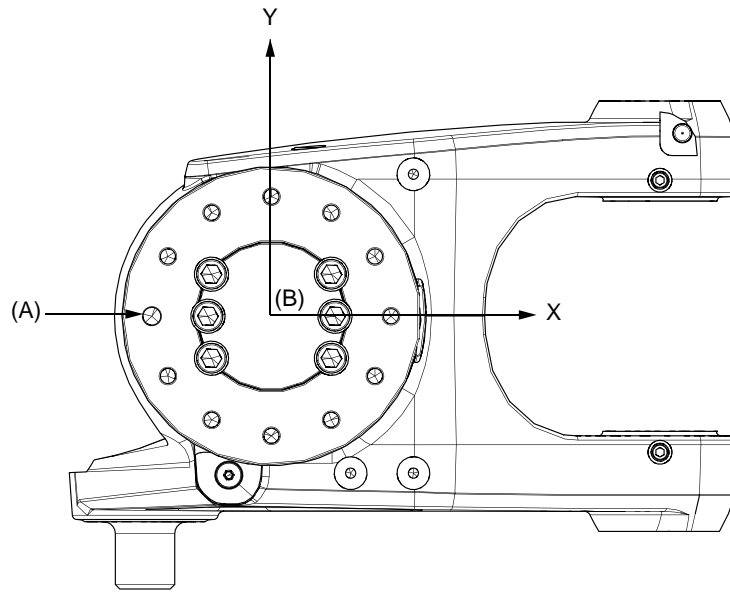

xx1800001377

-	Mounting flange in bottom view
A	Locating hole
B	Tool coordinate system

Fastener quality

When fitting tools on the tool flange, only use screws with quality 12.9. For other equipment use suitable screws and tightening torque for your application.

2 Installation and commissioning

2.3.9 Safety lamp (option for IRC5)

2.3.9 Safety lamp (option for IRC5)

Description

A signal lamp with a yellow fixed light can be mounted on the robot, as a safety device.

Installation

See the assembly instruction delivered with the signal lamp.

Function

The lamp is active in MOTORS ON mode.

Further information

Further information about the MOTORS ON/MOTORS OFF mode may be found in the product manual for the controller.

2.3.10 Loads fitted to the robot, stopping time and braking distances

General

Any loads mounted on the robot must be defined correctly and carefully (with regard to the position of center of gravity and mass moments of inertia) in order to avoid jolting movements and overloading motors, gears and structure.



CAUTION

Incorrectly defined loads may result in operational stops or major damage to the robot.

References

Load diagrams, permitted extra loads (equipment) and their positions are specified in the product specification. The loads must be defined in the software.

- *Operating manual - IRC5 with FlexPendant*
- *Operating manual - OmniCore*

Stopping time and braking distances

The performance of the motor brake depends on if there are any loads attached to the robot. For more information, see product specification listed in [References on page 10](#).

2 Installation and commissioning

2.3.11 Extended working range, axis 1 (option)

2.3.11 Extended working range, axis 1 (option)

Overview

The working range of axis 1 can be extended on a floor-mounted robot, from the default range limited by mechanical stops. The working range can be extended to $\pm 220^\circ$.



CAUTION

The option *Extended work range* enables an extension of the working range for axis 1, through a software configuration. With this option installed, the working range can exceed the range limited by the mechanical stop on axis 1. The working range shall be limited through the option *SafeMove*.

A risk analysis must be done to ensure that no risks remain when using option *Extended work range*, to limit the working range, and before removing the mechanical stops.

For information about the option *SafeMove*, see *Application manual - Functional safety and SafeMove*.

If the mechanical stop is removed, then the manipulator should have a marking for this, for example, a label. If the robot is delivered with the option *Extended work range*, then such a label is included on delivery.

Extending the working range

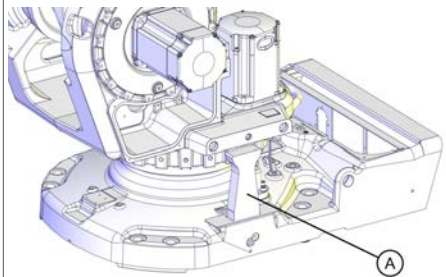
	Action	Note/Illustration
1	Configure the safety setup and verify it by test.	
2	Hold the mechanical stop pin in a firm grip, and remove it by unscrewing the attachment screw.	 xx2100001706
3	In RobotWare, redefine the working range limitations in the system parameters, topic <i>Motion</i> . The Arm parameters <i>Upper Joint Bound</i> and <i>Lower Joint Bound</i> can be changed to the values corresponding to the actual installation.	With the option <i>Extended working range</i> , the maximum value for the system parameters <i>Upper Joint Bound</i> and <i>Lower Joint Bound</i> is 3.84 respectively -3.84. The values are in radians, that is 3.84 radians = 220 degrees.

Related information

The system parameters are described in detail in the reference manual, see [References on page 10](#).

Continues on next page

For more information about SafeMove, see *Application manual - Functional safety and SafeMove2 (IRC5)* or *Application manual - Functional safety and SafeMove (OmniCore)*.

2 Installation and commissioning

2.4.1 Axes with restricted working range

2.4 Restricting the working range

2.4.1 Axes with restricted working range

General

When installing the robot, make sure that it can move freely within its entire working space. If there is a risk that it may collide with other objects, its working space should be limited.

The working range of the following axes may be restricted:

- Axis 1, hardware (mechanical stop)

As standard configuration, axis 1 is allowed to move $\pm 180^\circ$. The working range may however be increased to $\pm 220^\circ$ with option 561-1 *Extended working range axis 1*. Note that this option also requires installation of option 810-1 *Electronic position switch*.

This section describes how to install hardware that restricts the working range.



Note

Adjustments must also be made in the robot configuration software (system parameters). References to relevant manuals are included in the installation procedures.

2.4.2 Mechanically restricting the working range of axis 1

General

The working range of axis 1 is limited by fixed mechanical stops and adjustment of the system parameter configuration. The working range can be reduced by adding additional mechanical stops giving 7.5 or 15 graduation, between 22.5° and 135° in both directions.

Mechanical stops, axis 1

The illustration shows the mounting position of the stop pin and one of the additional mechanical stops available for axis 1.

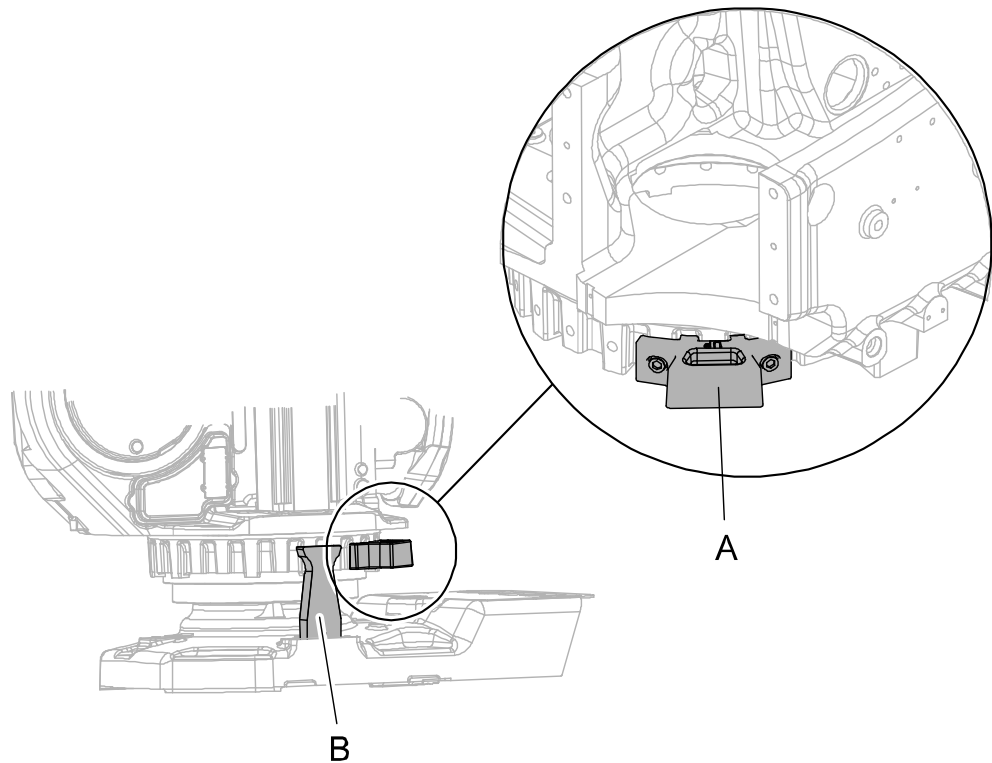

xx0300000049

A	Additional mechanical stop
B	Stop pin

Required equipment

Equipment, etc.	Article number	Note
Mechanical stop for axis 1, 7.5°	3HAC11076-1	Includes attachment screws and an assembly drawing.
Mechanical stop for axis 1, 15°	3HAC11076-2	Includes attachment screws and an assembly drawing.
Standard toolkit	-	
<i>Technical reference manual - System parameters</i>	-	Article number is specified in section References on page 10 .

Continues on next page



2 Installation and commissioning

2.4.2 Mechanically restricting the working range of axis 1

Continued

Installation, mechanical stops axis 1

Use this procedure to fit the additional mechanical stops to axis 1 of the robot. An assembly drawing is also enclosed with the product.

	Action	Note
1	 DANGER Turn off all: <ul style="list-style-type: none">• electric power supply to the robot• hydraulic pressure supply to the robot• air pressure supply to the robot Before entering the robot working area.	
2	Fit the additional mechanical stop to the frame according to the figure <i>Mechanical stops, axis 1 on page 81</i> .	Tightening torque: 120 Nm.
3	Adjust the software working range limitations (system parameter configuration) to correspond to the mechanical limitations.	The system parameters that must be changed (<i>Upper joint bound</i> and <i>Lower joint bound</i>) are described in <i>Technical reference manual - System parameters</i> .
4	 WARNING If the mechanical stop pin is deformed after a hard collision, it must be replaced! Deformed <i>movable stops</i> and/or <i>additional stops</i> as well as deformed <i>attachment screws</i> must also be replaced after a hard collision.	

2.5 Robot in cold environments

2.5.1 Start of robot in cold environments

Introduction

This section describes how to start the robot in a cold environment if it is not starting the normal way.

Problems with starting the robot

Event message from Motion Supervision

Use this procedure if an event message indicates a problem with Motion supervision at start-up. More information about Motion Supervision is found in *Technical reference manual - System parameters*.

	Action	Note
1	Turn off Motion Supervision.	
2	Start the robot.	
3	When the robot has reached normal working temperature, the Motion Supervision can be turned on again.	

Robot stopping with other event message

Use this procedure if the robot is not starting.

	Action	Note
1	Start the robot with its normal program but with reduced speed.	The speed can be regulated with the RAPID instruction <code>VelSet</code> .

Adjusting the speed and acceleration during warm-up

Depending on how cold the environment is and what program is being used, the speed might need to be ramped up until reached maximum. The table shows examples of how to adjust the speed:

Work cycles	AccSet	Speed/velocity
3 Work cycles	20, 20	v100 (100 mm/s)
5 Work cycles	40, 40	v400 (400 mm/s)
5 Work cycles	60, 60	v600 (600 mm/s)
5 Work cycles	100, 100	v1000 (1000 mm/s)
More than 5 Work cycles	100, 100	Max.

If the program consists of large wrist movements, it is possible that the reorientation velocity, which is always high in predefined velocities, needs to be included in the ramping up.

2 Installation and commissioning

2.6.1 Robot cabling and connection points

2.6 Electrical connections

2.6.1 Robot cabling and connection points

Introduction

Connect the robot and controller to each other after securing them to the foundation. The lists below specify which cables to use for each respective application.



CAUTION

Connect the male and female connectors perfectly aligned horizontally to avoid any kind of tilt or skew.



CAUTION

Verify that the robot serial number is according to the number(s) in the *Declaration of Incorporation (DoI)*.

Main cable categories

All cables between the robot and controller are divided into the following categories:

Cable category	Description
Robot cables	Handles power supply to and control of the robot's motors as well as feedback from the serial measurement board. Specified in the table Robot cables on page 84 .
Customer cables (option)	Handles communication with equipment fitted on the robot by the customer, low voltage signals and high voltage power supply + protective ground. The customer cables also handle databus communication. See the product manual for the controller, see document number in References on page 10 .
External axes cables (option)	Handles power supply to and control of the external axes' motors as well as feedback from the servo system. See <i>Application manual - Additional axes and stand alone controller (IRC5)</i> or <i>Application manual - Additional axes (OmniCore)</i> , document number in References on page 10 .

Robot cables

These cables are included in the standard delivery. They are completely pre-manufactured and ready to plug in.

Cable sub-category	Description	Connection point, cabinet	Connection point, robot
Robot cable, power	Transfers drive power from the drive units in the control cabinet to the robot motors.	XS1 (IRC5 controllers) X1 (OmniCore controllers)	R1.MP

Continues on next page

2 Installation and commissioning

2.6.1 Robot cabling and connection points

Continued

Cable sub-category	Description	Connection point, cabinet	Connection point, robot
Robot cable, signals	Transfers resolver data from and power supply to the serial measurement board.	XS2 (IRC5 controllers) X2 (OmniCore controllers)	R1.SMB

Robot cable, power

Cable	Art. no.
Robot cable, power: 7 m	3HAC026787-001
Robot cable, power: 15 m	3HAC026787-002
Robot cable, power: 22 m	3HAC026787-003
Robot cable, power: 30 m	3HAC026787-004

Robot cable, signals

Cable	Art. no.
Robot cable signal, shielded: 7 m	3HAC7998-1
Robot cable signal, shielded: 15 m	3HAC7998-2
Robot cable signal, shielded: 22 m	3HAC7998-3
Robot cable signal, shielded: 30 m	3HAC7998-4

Bending radius for static floor cables

The minimum bending radius is 10 times the cable diameter for static floor cables.

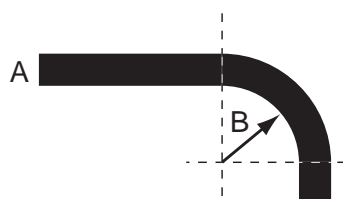

xx1600002016

A	Diameter
B	Diameter x10

Continues on next page

2 Installation and commissioning

2.6.1 Robot cabling and connection points

Continued

Grounding and bonding point on manipulator

There is a grounding/bonding point on the manipulator base. The grounding/bonding point is used for potential equalizing between control cabinet, manipulator and any peripheral devices.

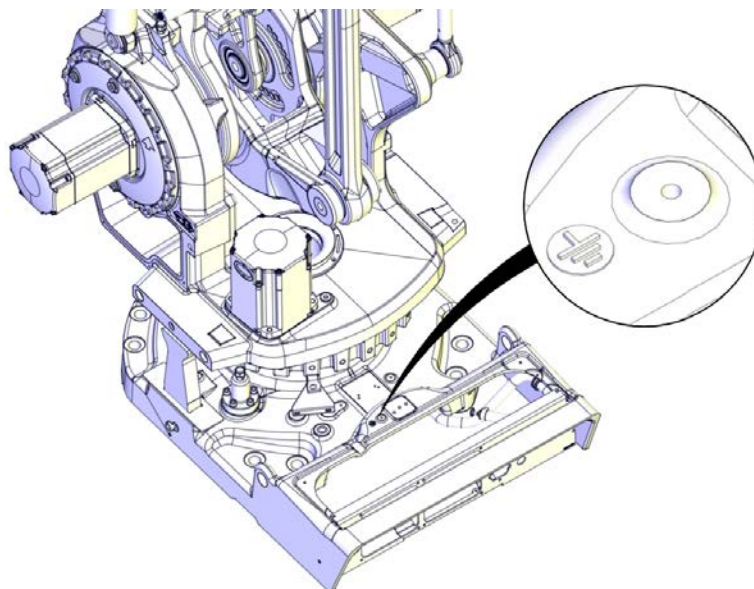

xx1600001007

2.6.2 Customer connectors on the manipulator

Introduction

The customer cables are routed internally with the manipulator cable harness. For more information and specifications for the connections. See section *Customer connections* in the Product Specification.

Location of customer connectors on manipulator

Customer connectors, base

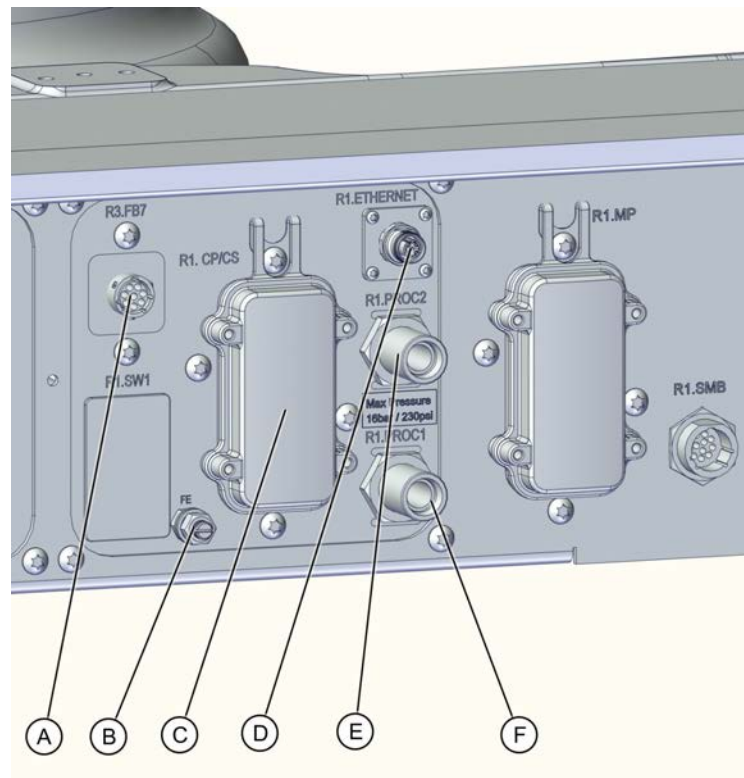

xx2100002206

Pos	Name	Description
A	R3.FB7	For the 7-axis connector on the manipulator base
B	FE	Grounding point
C	R1.CP/CS	Customer power/signal
D	R1.ETHERNET	Bus communication Ethernet IP
E	R1.PROC2	Process connector on the manipulator base.
F	R1.PROC1	Process connector on the manipulator base

Continues on next page

2 Installation and commissioning

2.6.2 Customer connectors on the manipulator

Continued

Customer connectors, wrist

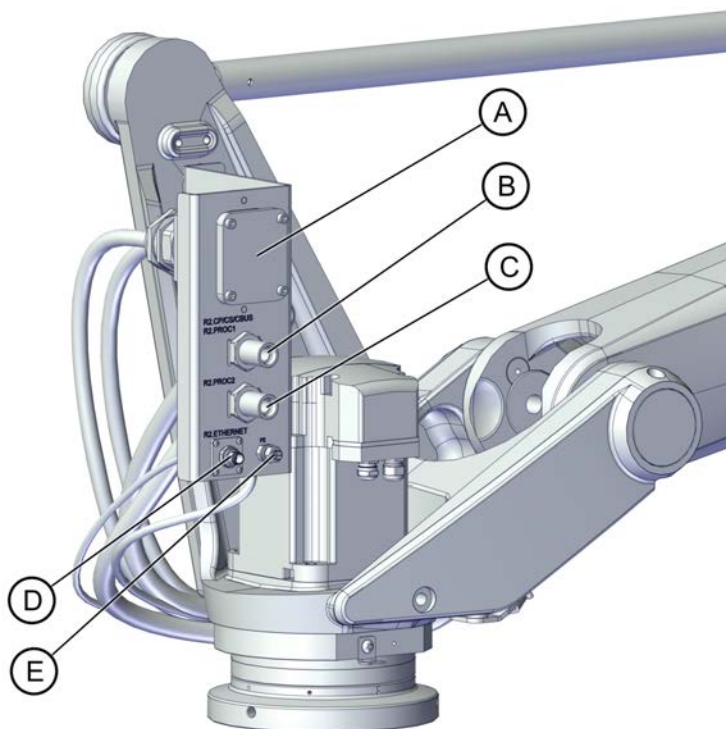

xx2100002207

Pos	Name	Description
A	R2.CP/CS/CBUS	Customer power/signal connector
B	R2.PROC1	Process connector on the manipulator wrist
C	R2.PROC2	Process connector on the manipulator wrist
D	R1.ETHERNET	Bus communication Ethernet IP
E	FE	Grounding point

2.7 Test run after installation, maintenance, or repair

Safe handling

Use the following procedure after installation, maintenance, or repair, before initiating motion.



DANGER

Initiating motion without fulfilling the following aspects, may increase the risk for injury or cause damage to the robot.

	Action
1	Remove all tools and foreign objects from the robot and its working area.
2	Verify that the robot is properly secured to its position by all screws, before it is powered up.
3	Verify that any safety equipment installed to secure the position or restrict the robot motion during service activity is removed.
4	Verify that the fixture and work piece are well secured, if applicable.
5	Verify that all safety equipment is installed, as designed for the application.
6	Verify that no personnel are inside the safeguarded space.
7	If maintenance or repair has been done, verify the function of the part that was maintained.
8	Verify the application in the operating mode manual reduced speed.

Collision risks



CAUTION

When programming the movements of the robot, always identify potential collision risks before initiating motion.

This page is intentionally left blank

3 Maintenance

3.1 Introduction

Structure of this chapter

This chapter describes all the maintenance activities recommended for the IRB 660.

It is based on the maintenance schedule found at the beginning of the chapter. The schedule contains information about required maintenance activities including intervals, and refers to procedures for the activities.

Each procedure contains all the information required to perform the activity, including required tools and materials.

The procedures are gathered in different sections and divided according to the maintenance activity.

Safety information

Observe all safety information before conducting any service work.

There are general safety aspects that must be read through, as well as more specific safety information that describes the danger and safety risks when performing the procedures. Read the chapter [Safety on page 19](#) before performing any service work.

The maintenance must be done by qualified personnel in accordance with the safety requirements set forth in the applicable national and regional standards and regulations.



Note

If the IRB 660 is connected to power, always make sure that the IRB 660 is connected to protective earth and a residual current device (RCD) before starting any maintenance work.

For more information see:

- *Product manual - OmniCore V250XT*
- *Product manual - IRC5*
- *Product manual - IRC5 Panel Mounted Controller*
- [Robot cabling and connection points on page 84.](#)

3 Maintenance

3.2.1 Specification of maintenance intervals

3.2 Maintenance schedule and expected component life

3.2.1 Specification of maintenance intervals

Introduction

The intervals are specified in different ways depending on the type of maintenance activity to be carried out and the working conditions of the IRB 660:

- Calendar time: specified in months regardless of whether the system is running or not.
- Operating time: specified in operating hours. More frequent running means more frequent maintenance activities.
- SIS: specified by the robot's SIS (Service Information System). A typical value is given for a typical work cycle, but the value will differ depending on how hard each part is run.

The SIS used in M2004 is further described in the *Operating manual - Service Information System (IRC5)* or *Operating manual - OmniCore*.

The SIS used in OmniCore is further described in the *Operating manual - OmniCore*.

Robots with the functionality *Service Information System* activated can show active counters in the device browser in RobotStudio, or on the FlexPendant.

Overhaul

Depending on application and operational environment a complete overhaul may be necessary in average around 40000 hours.

ABB Connected Services and its Assessment tools can help you to identify the real stress level of your robot, and define the optimal ABB support to maintain your robot working.

Contact your local ABB Customer Service to get more information.

3.2.2 Maintenance schedule

General

The robot must be maintained regularly to ensure proper function. The maintenance activities and intervals are specified in the table below.

Non-predictable situations also give rise to inspections of the robot. Any damage must be attended to immediately.

The inspection intervals *do not* specify the life of each component. Values for these are specified in the section [Expected component life on page 95](#)

Instructions for how to perform the different maintenance activities are found in sections:

- [Inspection activities on page 96](#)
- [Replacement/changing activities on page 120](#)
- [Cleaning activities on page 137](#)

Activities and intervals, standard equipment

The table below specifies the required maintenance activities and intervals.

Maintenance activity	Equipment	Interval
Cleaning	Robot	-
Inspection	Axis-1 gearbox, oil level	Every: <ul style="list-style-type: none"> • 12 months
Inspection	Axes-2 and -3 gearboxes, oil level	Every: <ul style="list-style-type: none"> • 12 months
Inspection	Axis-6 gearbox, oil level	Every: <ul style="list-style-type: none"> • 12 months
Inspection	Balancing device	Every: <ul style="list-style-type: none"> • 12 months
Inspection	Robot harness	Every: <ul style="list-style-type: none"> • 12 monthsⁱ
Inspection	Information labels	Every: <ul style="list-style-type: none"> • 12 months
Inspection	Mechanical stop, axis 1	Every: <ul style="list-style-type: none"> • 12 months
	Mechanical stop, axis 3 (only applicable for IRB 760 - 445/3.2)	Every: <ul style="list-style-type: none"> • 12 months
Inspection	Dampers	Every: <ul style="list-style-type: none"> • 12 months
Changing	Axis-1 gear oil	First change when DTC ⁱⁱ reads: <ul style="list-style-type: none"> • 6,000 hours Second change when DTC ⁱⁱ reads: <ul style="list-style-type: none"> • 24,000 hours Following changes: <ul style="list-style-type: none"> • Every 24,000 hours

Continues on next page

3 Maintenance

3.2.2 Maintenance schedule

Continued

Maintenance activity	Equipment	Interval
Changing	Axis 2 gear oil	First change when DTC ⁱⁱ reads: <ul style="list-style-type: none"> • 6,000 hours Second change when DTC ⁱⁱ reads: <ul style="list-style-type: none"> • 24,000 hours Following changes: <ul style="list-style-type: none"> • Every 24,000 hours
Changing	Axis-3 gear oil	First change when DTC ⁱⁱ reads: <ul style="list-style-type: none"> • 6,000 hours Second change when DTC ⁱⁱ reads: <ul style="list-style-type: none"> • 24,000 hours Following changes: <ul style="list-style-type: none"> • Every 24,000 hours
Changing	Axis-6 gear oil	First change when DTC ⁱⁱ reads: <ul style="list-style-type: none"> • 6,000 hours Second change when DTC ⁱⁱ reads: <ul style="list-style-type: none"> • 24,000 hours Following changes: <ul style="list-style-type: none"> • Every 24,000 hours
Overhaul	Robot	40,000 hours
Replacement	Battery pack, measurement system of type RMU101 or RMU102 (3-pole battery contact)	36 months or battery low alert ⁱⁱⁱ
Replacement	Battery pack, measurement system with 2-pole battery contact, e.g. DSQC633A	Battery low alert ^{iv}
Lubrication	Balancing device bearings	Every 12,000 hours

ⁱ Replace when damage or cracks are detected or life limit is approaching as specified in section [Expected component life on page 95](#).

ⁱⁱ DTC = Duty Time Counter. Shows the operational time of the robot.

ⁱⁱⁱ The battery low alert (38213 **Battery charge low**) is displayed when the battery needs to be replaced. The recommendation to avoid an unsynchronized robot is to keep the power to the controller turned on until the battery is to be replaced.
See the replacement instruction for more details.

^{iv} The battery low alert (38213 **Battery charge low**) is displayed when remaining backup capacity (robot powered off) is less than 2 months. The typical lifetime of a new battery is 36 months if the robot is powered off 2 days/week or 18 months if the robot is powered off 16 h/day. The lifetime can be extended with a battery shutdown service routine. See the operating manual for the robot controller for instructions.

Activities and intervals, optional equipment

The table below specifies the required maintenance activities and intervals for common optional equipment. The maintenance of other external equipment for the robot is detailed in separate documentation.

Maintenance activity	Equipment	Interval
Inspection	Signal lamp	Every: 12 months
Inspection	Additional mechanical stop axis 1	Every: 12 months

3.2.3 Expected component life

General

The expected life of a specific component of the robot can vary greatly depending on how hard it is run.

Expected component life - protection type Standard

Component	Expected life	Note
Cable harness Normal usage ⁱ	40,000 hours ⁱⁱ	Not including: <ul style="list-style-type: none"> • Possible SpotPack harnesses • Optional upper arm harnesses
Cable harness Extreme usage ⁱⁱⁱ	20,000 hours ⁱⁱ	Not including: <ul style="list-style-type: none"> • Possible SpotPack harnesses • Optional upper arm harnesses
Balancing device	40,000 hours ^{iv}	
Gearboxes ^v	40,000 hours	

ⁱ Examples of "normal usage" in regard to movement: most material handling applications. See the note in the Product specification about warranty, when running the robot in a cold environment (0°C to 5°C).

ⁱⁱ Severe chemical or thermal environments, or similar environments, can result in shortened life expectancy.

ⁱⁱⁱ Examples of "extreme usage" in regard to movement: press tending, very severe palletizing applications, major use of axis 1 movement.

^{iv} The given life for the balancing device is based on a test cycle of 4,000,000 cycles that starts from the initial position and goes to maximum extension, and back. Deviations from this cycle will result in differences in expected life!

^v Depending on application, the lifetime can vary. The Service Information System (SIS) that is integrated in the robot software can be used as guidance when planning gearbox service for the individual robot. This applies to gearboxes on axes 1, 2, 3 and 6. The lifetime of gearbox axes 4 and 5 is not calculated by SIS (See the *Operating manual - Service Information System*). In some applications, such as Foundry or Washing, the robot can be exposed to chemicals, high temperature or humidity, which can have an effect on the lifetime of the gearboxes. Contact the local *ABB Robotics Service team* for more information.

The SIS for an IRC5 system is described in the *Operating manual - Service Information System*.

3 Maintenance

3.3.1 Inspecting the oil level in axis-1 gearbox

3.3 Inspection activities

3.3.1 Inspecting the oil level in axis-1 gearbox

Location of gearbox

The axis-1 gearbox is located between the frame and base. See oil plugs in the following figure.

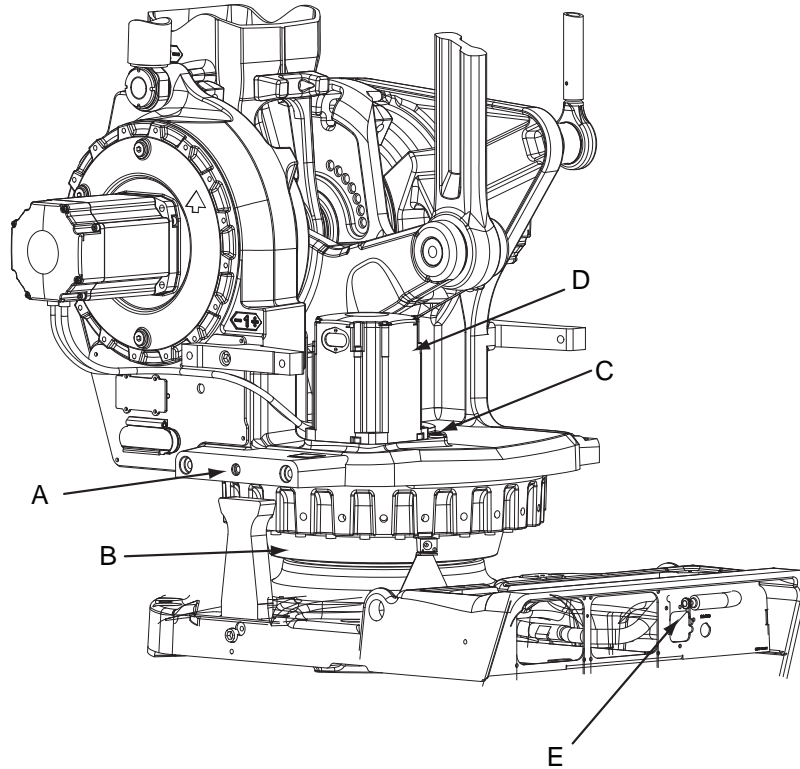

xx0500002479

A	Oil plug, inspection
B	Gearbox, axis 1
C	Oil plug filling
D	Motor, axis 1
E	Drain hose (Behind cover)

Required equipment



Equipment	Art. no.	Note
Lubricating oil	See <i>Type and amount of oil in gearboxes on page 120.</i>	 Note Do not mix with other oils!
Standard toolkit	-	Content is defined in section <i>Standard tools on page 346.</i>

Continues on next page

Equipment	Art. no.	Note
Other tools and procedures may be required. See references to these procedures in the step-by-step instructions below.		These procedures include references to the tools required.

Inspecting the oil level in axis-1 gearbox

Use this procedure to inspect the oil level in the axis-1 gearbox.

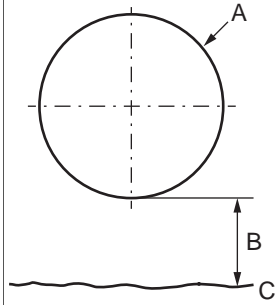
	Action	Note
1	 WARNING Handling gearbox oil involves several safety risks, see Gearbox lubricants (oil or grease) on page 34 .	
2	 DANGER Turn off all: <ul style="list-style-type: none"> • electric power supply • hydraulic pressure supply • air pressure supply to the robot, before entering the safeguarded space.	
3	Make sure that the oil temperature is $+25^{\circ}\text{C} \pm 10^{\circ}\text{C}$.	This is a precaution to reduce the temperature dependency of the measurement.
4	Open the <i>oil plug, inspection</i> .	Shown in figure Location of gearbox on page 96 .
5	Measure the oil level. Required oil level: max. 10 mm below the oil plug hole.	 <p>xx1400002785</p> <p>A Oil plug hole B Required oil level C Gearbox oil</p>
6	Adjust the oil level, if required.	Where to find type of oil and total amount is detailed in Type of lubrication in gearboxes on page 120 . Further information about how to fill with oil is found in section Changing oil, axis-1 gearbox on page 121 .
7	Refit the oil plug.	Tightening torque:

3 Maintenance

3.3.2 Inspecting, oil level gearbox axes 2 - 3

3.3.2 Inspecting, oil level gearbox axes 2 - 3

Location of gearbox, axes 2-3

The gearboxes axes 2-3 are located in the lower arm rotational center, underneath the motor attachment.

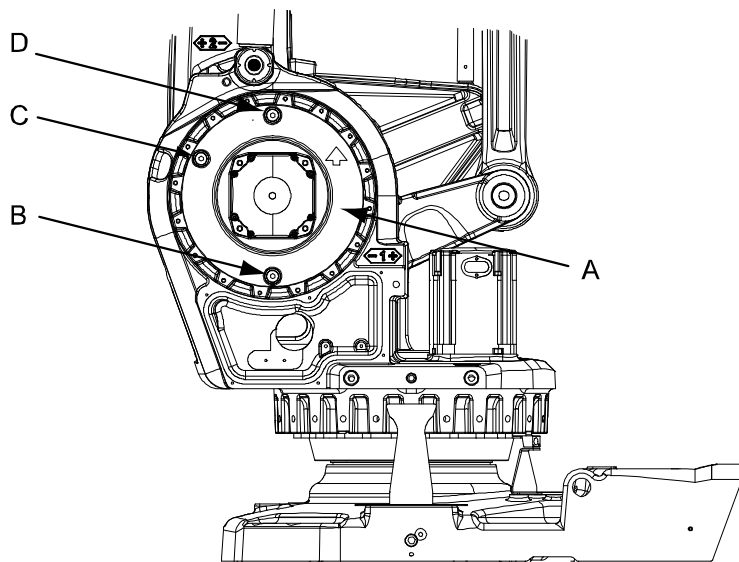

xx0500002482

A	Gearbox, axis 2
B	Oil plug, draining
C	Oil plug, filling
D	Ventilation hole, gearbox axis 2

Continues on next page

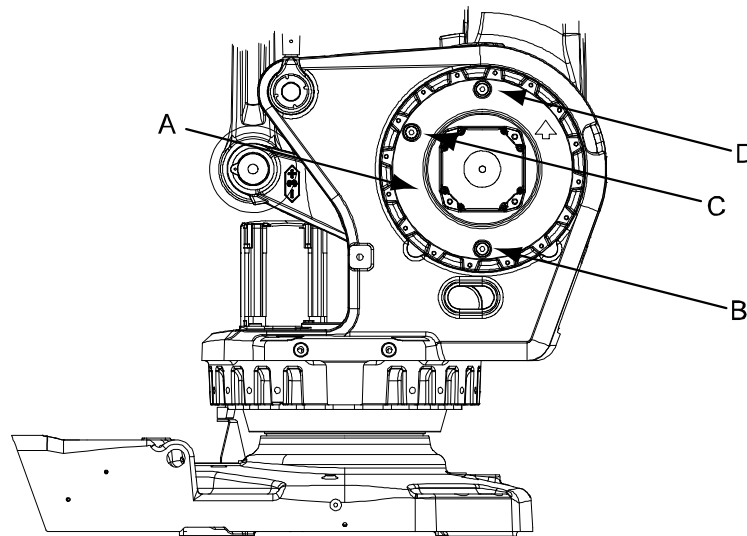

xx0500002483

A	Gearbox, axis 3
B	Oil plug, draining
C	Oil plug, filling
D	Ventilation hole, gearbox axis 3

Required equipment

Equipment etc.	Art.no.	Note
Lubricating oil	See <i>Type and amount of oil in gearboxes on page 120.</i>	 Note Do not mix with other oils!
Standard toolkit	-	Content is defined in section <i>Standard tools on page 346.</i>
Other tools and procedures may be required. See references to these procedures in the step-by-step instructions below		These procedures include references to the tools required.

Inspecting, oil level gearbox 2 - 3

Use this procedure to inspect the oil level in gearbox axes 2 - 3.

	Action	Note
1	 WARNING Handling gearbox oil involves several safety risks, see <i>Gearbox lubricants (oil or grease) on page 34.</i>	

Continues on next page

3 Maintenance

3.3.2 Inspecting, oil level gearbox axes 2 - 3

Continued

	Action	Note
2	 DANGER Turn off all: <ul style="list-style-type: none">• electric power supply• hydraulic pressure supply• air pressure supply to the robot, before entering the safeguarded space.	
3	Open <i>oil plug, filling</i>	See Location of gearbox, axes 2-3 on page 98 .
4	Measure oil level at the oil plug, filling. Required oil level: max. 5 mm below oil plug hole.	
5	Add <i>oil</i> if required.	Art.no. is specified in Required equipment on page 99 . Filling of oil is detailed further in section Changing oil, gearbox axes 2 and 3 on page 124 .
6	Refit oil plug, filling.	Tightening torque: 24 Nm.

3.3.3 Inspecting, oil level gearbox axis 6

Location of gearbox

The axis 6 gearbox is located in the tilthouse unit as shown in this figure.

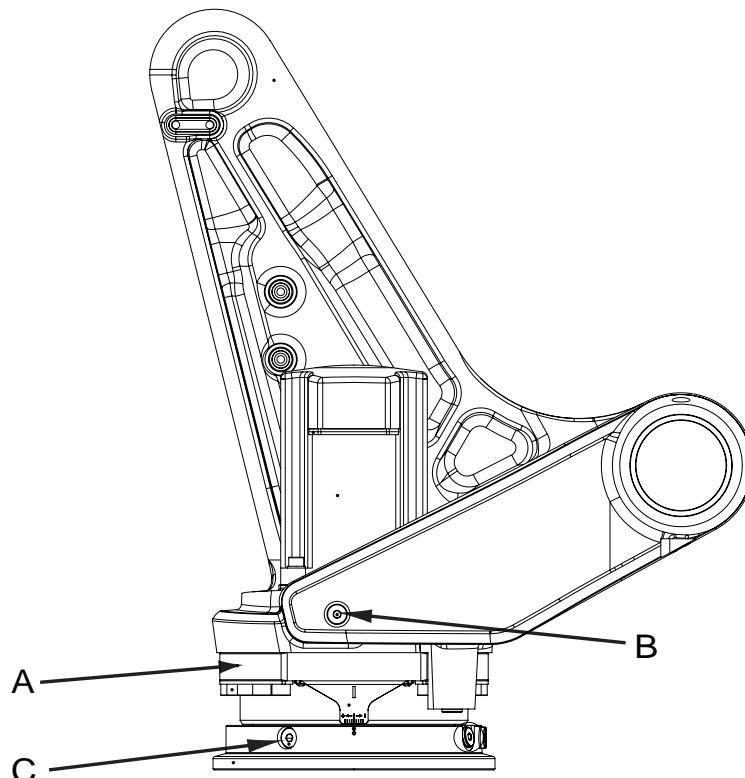

xx0500002484

A	Gearbox, axis 6
B	Oil plug, filling
C	Oil plug, draining

Required equipment

Equipment	Art. no.	Note
Lubricating oil	3HAC0860-1	Optimol Optigear BM 100
Standard toolkit	-	Content is defined in section Standard tools on page 346 .
Other tools and procedures may be required. See references to these procedures in the step-by-step instructions below.		These procedures include references to the tools required.

Continues on next page



3 Maintenance

3.3.3 Inspecting, oil level gearbox axis 6

Continued

Inspection, oil level axis-6 gearbox

Use this procedure to inspect the oil level in the axis-6 gearbox.

	Action	Note
1	 WARNING Handling gearbox oil involves several safety risks, see Gearbox lubricants (oil or grease) on page 34 .	
2	 DANGER Turn off all: <ul style="list-style-type: none">• electric power supply• hydraulic pressure supply• air pressure supply to the robot, before entering the safeguarded space.	
3	Open <i>oil plug, filling</i> .	Shown in figure Location of gearbox on page 101 .
4	Required oil level: max. 5 mm below the oil plug hole.	
5	Add <i>oil</i> if required.	Art. no. is specified in Required equipment on page 101 . Further information about how to fill the oil may be found in the section Changing oil, gearbox axis 6 on page 128 .
6	Refit oil plug, filling.	Tightening torque: 20 Nm

3.3.4 Inspecting, balancing device bearings and piston rod guide ring

Location of balancing device

The figure shows the location of the balancing device.

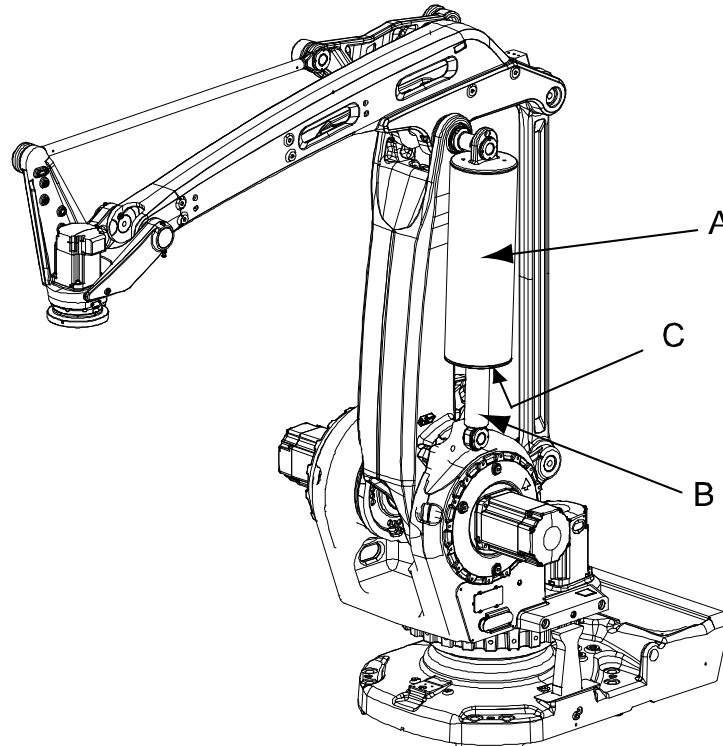

xx0500002495

A	Balancing device
B	Piston rod
C	Guide ring (not visible in this figure)

Required equipment

Equipment	Art.no	Note
Grease	3HAC042536-001	Shell Gadus S2
Locking liquid	-	Loctite 243
Auxiliary shaft, upper	3HAC5276-1	
Auxiliary shaft, lower	3HAC5275-1	
Standard toolkit	-	Content is defined in section Standard tools on page 346 .
Other tools and procedures may be required. See references to these procedures in the step-by-step instructions below.		These procedures include references to the tools required.

Continues on next page

3 Maintenance

3.3.4 Inspecting, balancing device bearings and piston rod guide ring

Continued

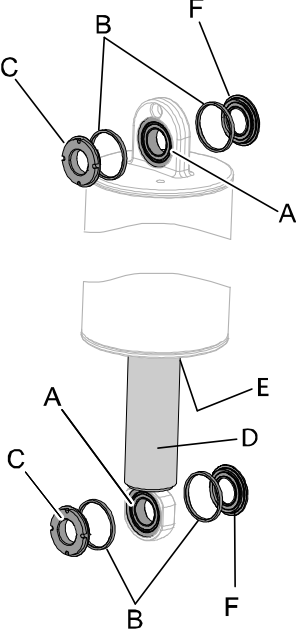

Inspecting, bearings

Use this procedure to inspect the bearings, balancing device.

	Action	Note
1	Move axis 2 to calibration position.	
2	 <p>DANGER</p> <p>Turn off all:</p> <ul style="list-style-type: none"> • electric power supply • hydraulic pressure supply • air pressure supply <p>to the robot, before entering the safe-guarded space.</p>	
3	Remove locknuts (KM10), sealing rings and support washers.	 <p>xx0500002496</p> <ul style="list-style-type: none"> A Ear (adjustable needle bearing located inside) B Support washer C Lock nut KM10 (with sealing ring) D Piston rod E Guide ring (not visible in this view) F Inner ring
4	Fit the <i>auxiliary shafts</i> on upper and lower axes of balancing device. The shafts should be tightened to their bottom position.	Art. no. is specified in <i>Required equipment on page 103</i> .

Continues on next page

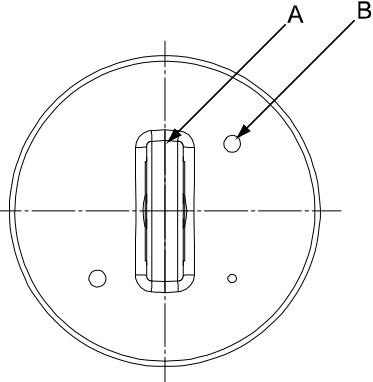
3.3.4 Inspecting, balancing device bearings and piston rod guide ring Continued

	Action	Note
5	Remove the protection hood from the M12 hole on top of the balancing device.	 <p>xx0600002687</p> <p>A Attachment (seen from above) B Protection hood</p>
6	Unload the bearings using a M12x50 screw, in the hole for the protective hood, at the cylinder top.	
7	Pull out the cylinder a little, in order to be able to inspect the <i>inner rings</i> without removing the balancing cylinder.	Shown in previous figure in this procedure.
8	Wipe the inner rings clean and check that there are no pressure marks or other similar deformations.	 Note It is quite normal for the bearing races to have a darker color than the surrounding material.
9	Inspect the <i>bearings, support washers and sealing rings</i> .	Shown in previous figure.
10	If any of the parts looks abnormal, replace.	Detailed in section Replacing the balancing device on page 234 .
11	Lubricate the shafts, if needed.	
12	Push the cylinder back in.	Make sure that the inner support washers and sealing rings get in the correct position.
13	Remove the auxiliary shafts.	
14	Remove the M12x50 screw. Put back the protection hood in the hole.	 Note Don't forget to remove the screw! If the screw isn't removed it may damage the balancing device, when the robot starts operating.
15	Apply <i>locking liquid</i> on the lock nuts (KM10) and refit them.	Tightening torque on the lock nuts: <ul style="list-style-type: none"> • 120 Nm

Continues on next page



3 Maintenance

3.3.4 Inspecting, balancing device bearings and piston rod guide ring

Continued

Inspecting, piston rod guide ring

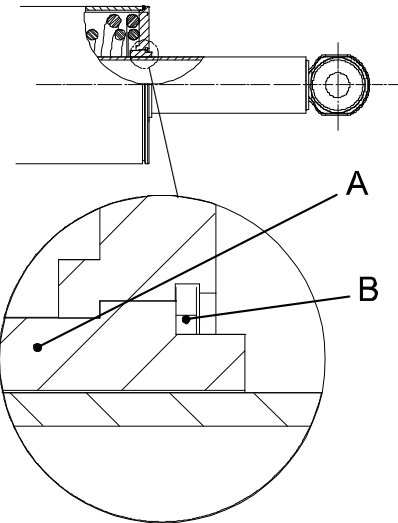
Use this procedure to inspect the piston rod guide ring for wear.

	Action	Note
1	Move axis 2 to a position where the balancing device is in a horizontal position.	
2	 DANGER Turn off all: <ul style="list-style-type: none"> • electric power supply • hydraulic pressure supply • air pressure supply to the robot, before entering the safeguarded space.	
3	Check the guide ring for wear. Replace if necessary.	 <p data-bbox="1002 1310 1109 1332">xx0600002689</p> <p data-bbox="1029 1344 1189 1411"> A Guide ring B Circlip </p>
4	 Note If there is a risk of metallic contact between the piston rod and the end cover, the guide ring must be replaced!	

3.3.5 Inspecting, cable harness

Location of cable harness, axes 1-6

The axes-1-6 cable harness is shown below.

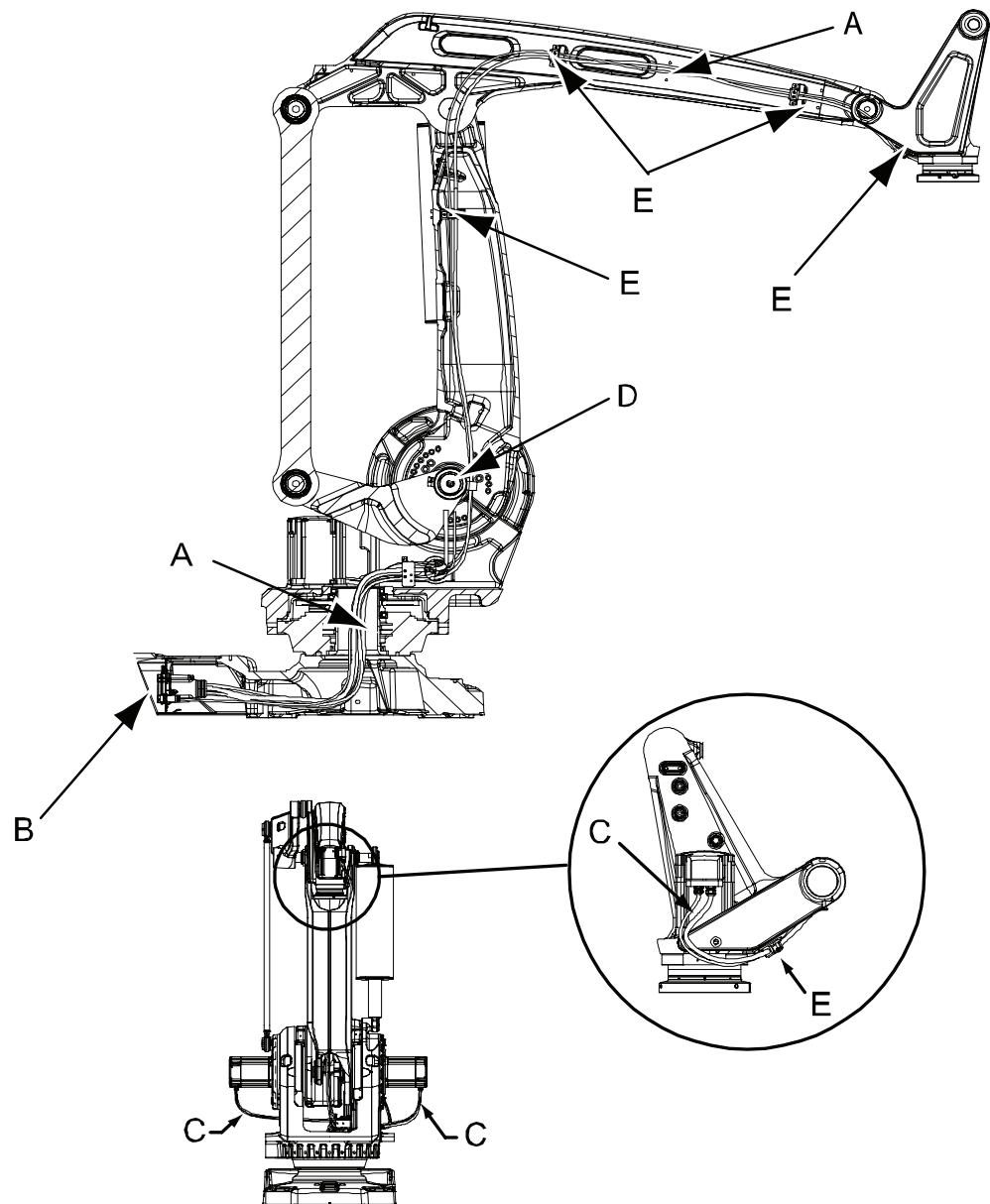

xx0500002497

A	Cable harness robot, axes 1-6
B	Connectors at base
C	Motor cables
D	Cable guide, axis 2
E	Metal clamps

Continues on next page

3 Maintenance

3.3.5 Inspecting, cable harness

Continued

Required equipment

Visual inspection, no tools are needed.

Inspecting cable harness, axes 1-6

Use this procedure to inspect cable harness of axes 1-6.

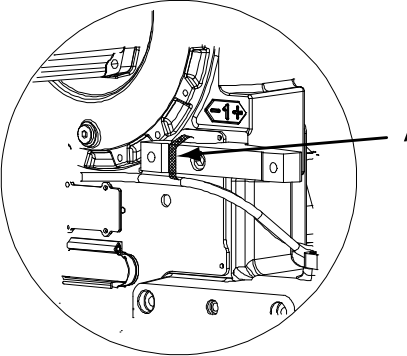
	Action	Note
1	 <p>DANGER</p> <p>Turn off all:</p> <ul style="list-style-type: none"> • electric power supply • hydraulic pressure supply • air pressure supply <p>to the robot, before entering the safeguarded space.</p>	
2	Make an overall inspection of the cable harness in order to detect wear and damage.	
3	Check the <i>connectors at the base</i> .	Shown in figure Location of cable harness, axes 1-6 on page 107
4	Check the <i>motor cables</i> .	Shown in figure Location of cable harness, axes 1-6 on page 107 .
5	If the robot is equipped with a fork lift device, check that the velcro strap that holds the motor cable is properly attached to the adapter.	 <p>xx0600002691</p> <p>Velcro strap</p>
6	Check the <i>cable guide axis 2</i> . Replace if damaged.	Shown in figure Location of cable harness, axes 1-6 on page 107 .
7	Check the <i>metal clamps</i> on the lower arm.	Shown in figure Location of cable harness, axes 1-6 on page 107

Continues on next page

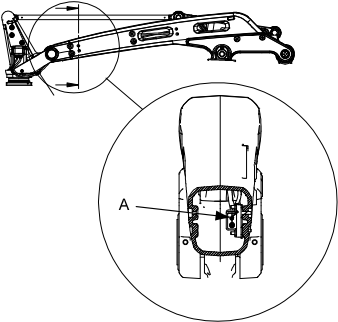
	Action	Note
8	Check the metal clamps holding the cable harness inside the upper arm, as shown in figure to the right.	 <p>xx0500002498</p> <p>A: Metal clamp inside upper arm</p>
9	Check the metal clamp holding the motor cable on axis 6.	Shown in figure Location of cable harness, axes 1-6 on page 107 .
10	Replace the cable harness if wear or damage is detected!	Detailed in section: Replacing cable harness, lower end (axes 1-3) on page 148 . Replacing the cable harness, upper end (incl. axis 6) on page 156 .

3 Maintenance

3.3.6 Inspecting the information labels

3.3.6 Inspecting the information labels

Location of labels

These figures show the location of the information labels to be inspected. The symbols are described in section [Safety symbols on manipulator labels on page 23](#).

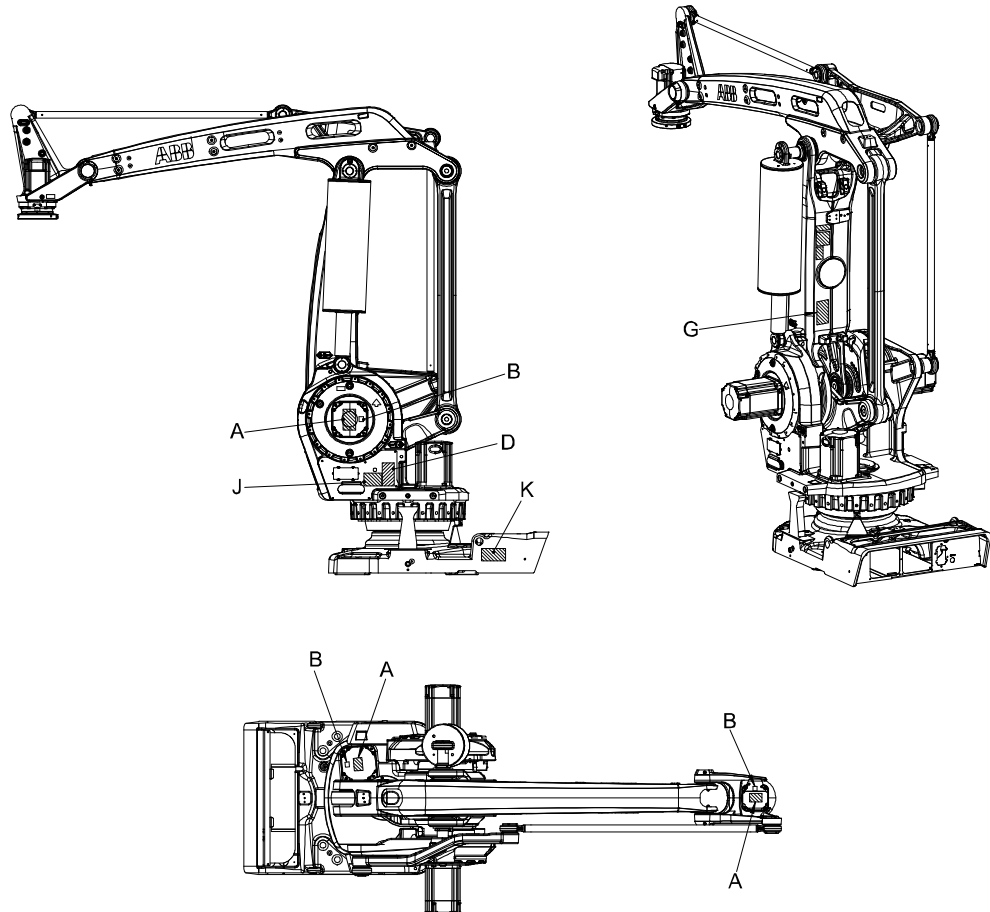

xx0500002499

A	Warning label concerning high temperature (located on motor cover) (4 pcs)
B	Warning label, symbol of flash (located on motor cover) (4 pcs)
D	Warning label concerning brake release
G	Warning label
J	Warning label
K	Warning label concerning extended working range (option)
-	Information labels at gearboxes and at robot base, specifying which oil is used in gearboxes.

Continues on next page

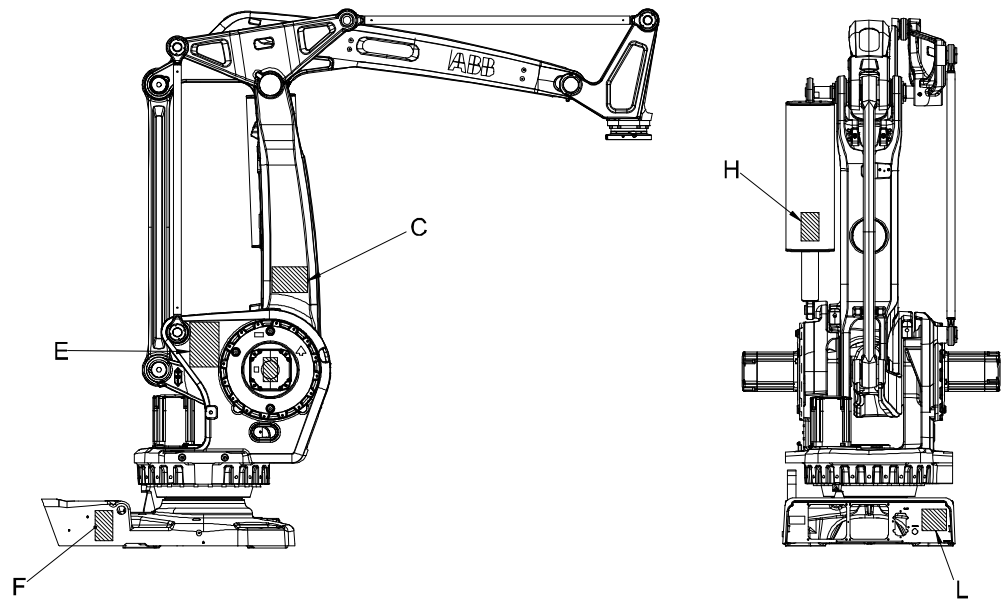

xx0500002500

C	Instruction label
E	Instruction label concerning lifting the robot
F	Warning label concerning risk of tipping
H	Warning label concerning stored energy
L	Information label at base, Kyodo Yushi TMO 150 in gearboxes

Required tools and equipment

Visual inspection, no tools are required.

Inspecting, labels

	Action	Note
1	 DANGER Turn off all: <ul style="list-style-type: none"> • electric power supply • hydraulic pressure supply • air pressure supply to the robot, before entering the safeguarded space.	
2	Inspect the labels, located as shown in the figures.	
3	Replace any missing or damaged labels.	Article numbers for the labels and plate set is specified in Spare part lists on page 351 .

3 Maintenance

3.3.7 Inspecting the axis-1 mechanical stop pin

3.3.7 Inspecting the axis-1 mechanical stop pin



WARNING

Mechanical stop pin can not be fitted onto robot if option 810-1 *Electronic Position Switch* is used.



WARNING

Mechanical stop pin can not be fitted onto robot if the option 561-1 *Extended working range* is used for axis 1.

Location of mechanical stop pin

The axis-1 mechanical stop is located as shown in the figure.

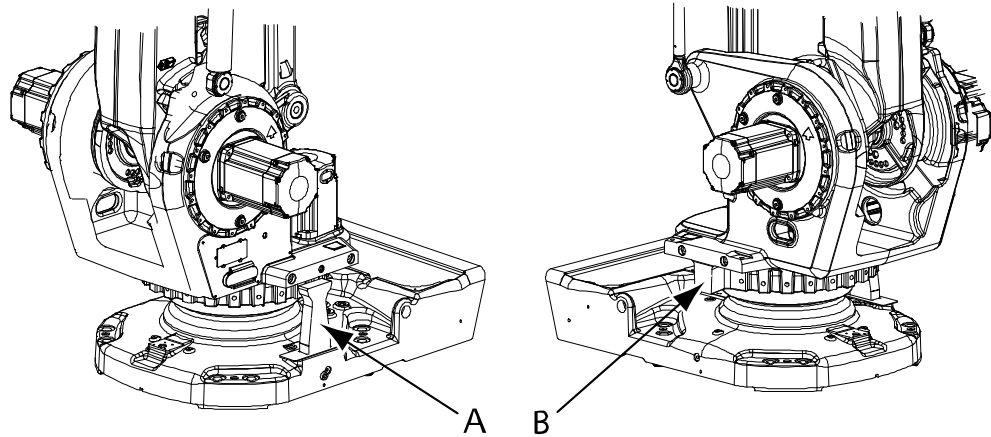

xx0600002695

A	Mechanical stop pin
B	Fixed stop

Required equipment

Visual inspection, no tools are required.

Inspecting, mechanical stop pin

Use this procedure to inspect the axis-1 mechanical stop pin.

Action	Note
<p>1</p> <p> DANGER</p> <p>Turn off all:</p> <ul style="list-style-type: none"> • electric power supply • hydraulic pressure supply • air pressure supply <p>to the robot, before entering the safeguarded space.</p>	

Continues on next page

	Action	Note
2	<p>Inspect the axis-1 mechanical stop pin. If the mechanical stop pin is bent or damaged, it must be replaced.</p> <p> Note</p> <p>The expected life of gearboxes can be reduced after collision with the mechanical stop.</p>	
3	<p>Make sure the mechanical stop pin can move in both directions.</p>	

3 Maintenance

3.3.8 Inspecting the additional mechanical stops

3.3.8 Inspecting the additional mechanical stops

Location of mechanical stops

This figure shows the location of the additional mechanical stops on axis 1. (The figure shows IRB 7600 but the location on axis 1 is the same on IRB 660.)

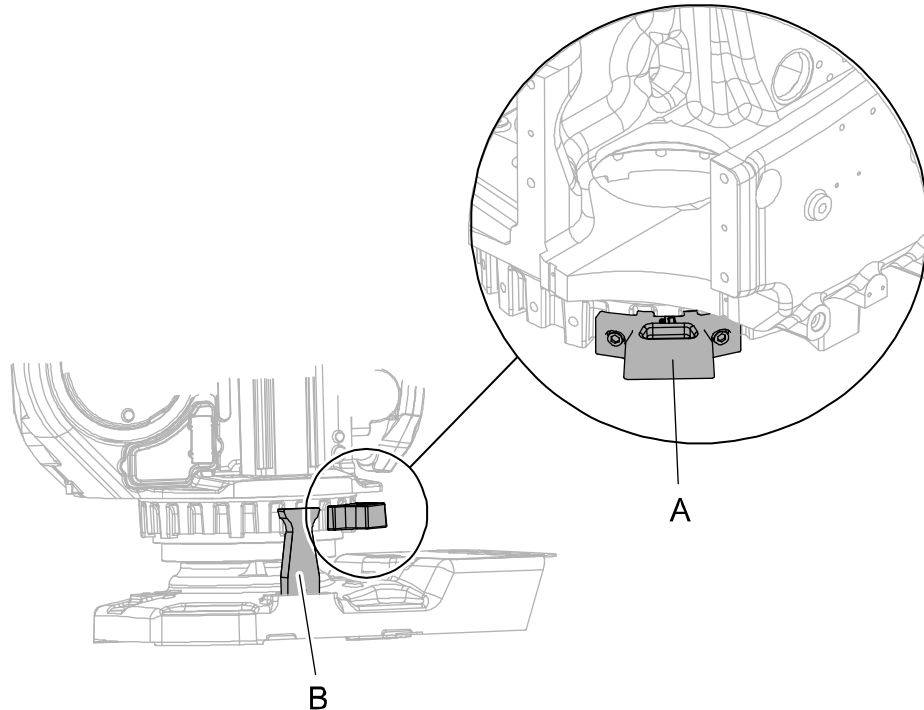

xx030000049

A	Additional mechanical stop
B	Stop pin

Required equipment

Equipment etc.	Article number	Note
Standard toolkit	-	Content is defined in section Standard tools on page 346 .

Inspecting, mechanical stops

Use this procedure to inspect the additional mechanical stops.

Action	Note
<p>1</p> <p> DANGER</p> <p>Turn off all:</p> <ul style="list-style-type: none"> • electric power supply • hydraulic pressure supply • air pressure supply <p>to the robot, before entering the robot working area.</p>	

Continues on next page

	Action	Note
2	Make sure no additional stops are damaged.	Shown in figure Location of mechanical stops on page 114 .
3	Make sure the stops are properly attached. Correct tightening torque, additional mechanical stops: <ul style="list-style-type: none">• Axis 1 = 120 Nm.	
4	If any damage is detected, the mechanical stops must be replaced. Correct attachment screws: <ul style="list-style-type: none">• Axis 1: M16 x 35, quality 12.9.	Article number is specified in Required equipment on page 114 .

3 Maintenance

3.3.9 Inspection, dampers

3.3.9 Inspection, dampers

Location of dampers

This figure shows the location of dampers.

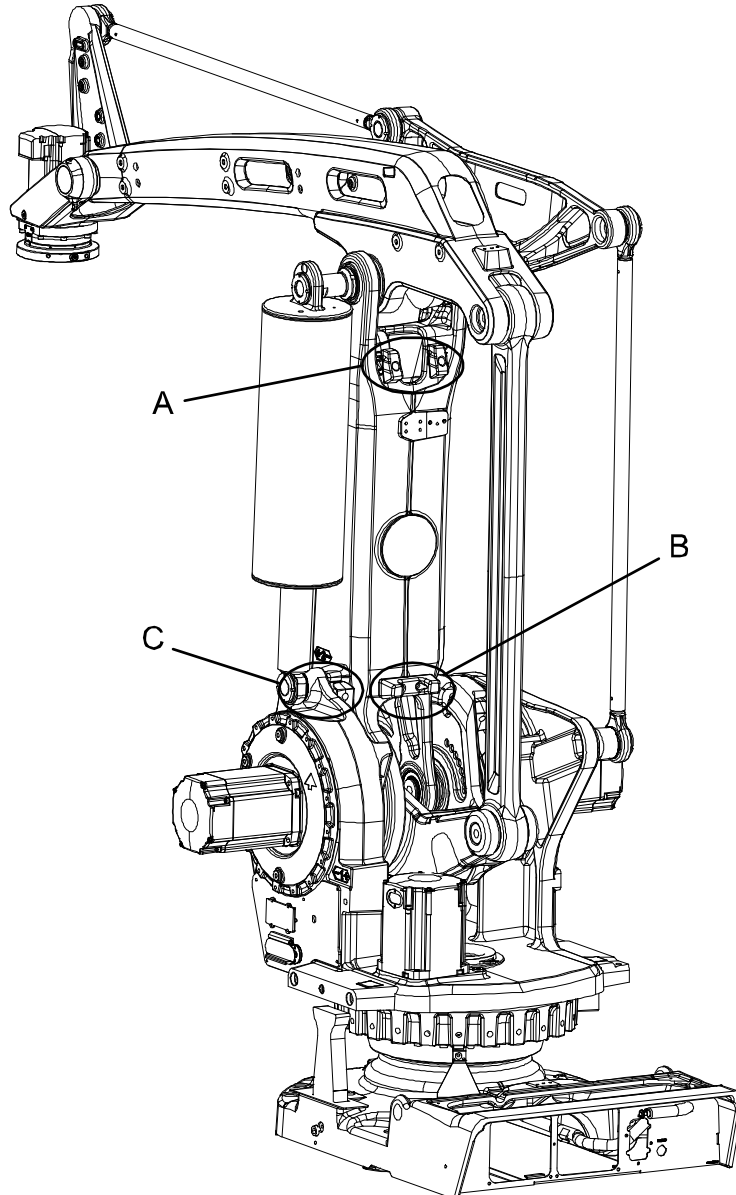

xx0500002501

A	Damper, lower arm, upper (2 pcs)
B	Damper, lower arm, lower (1 pc)
C	Damper, axis 2 (2 pcs)
-	Damper, axis 3 (2 pcs). Not visible in this view.

Continues on next page

Required equipment

Equipment	Art.no.	Note
Damper lower arm, upper	See Spare part lists on page 351 .	To be replaced if damaged.
Damper lower arm, lower	See Spare part lists on page 351 .	To be replaced if damaged.
Damper axis 2, 3	See Inspection, dampers on page 116 .	To be replaced if damaged.

Inspecting, dampers

Use this procedure to inspect the dampers.

	Action	Note
1	 <p>DANGER</p> <p>Turn off all:</p> <ul style="list-style-type: none"> • electric power supply • hydraulic pressure supply • air pressure supply <p>to the robot, before entering the safeguarded space.</p>	
2	Check all <i>dampers</i> for damage, cracks or existing impressions larger than 1 mm.	Shown in figure Location of dampers on page 116 .
3	Check attachment screws for deformation.	
4	If any damage is detected, the <i>damper</i> must be replaced with a new one.	Art.no. is specified in Required equipment on page 117 .

3 Maintenance

3.3.10 Inspecting the signal lamp (option)

3.3.10 Inspecting the signal lamp (option)

Location of signal lamp

The signal lamp is located as shown in this figure.

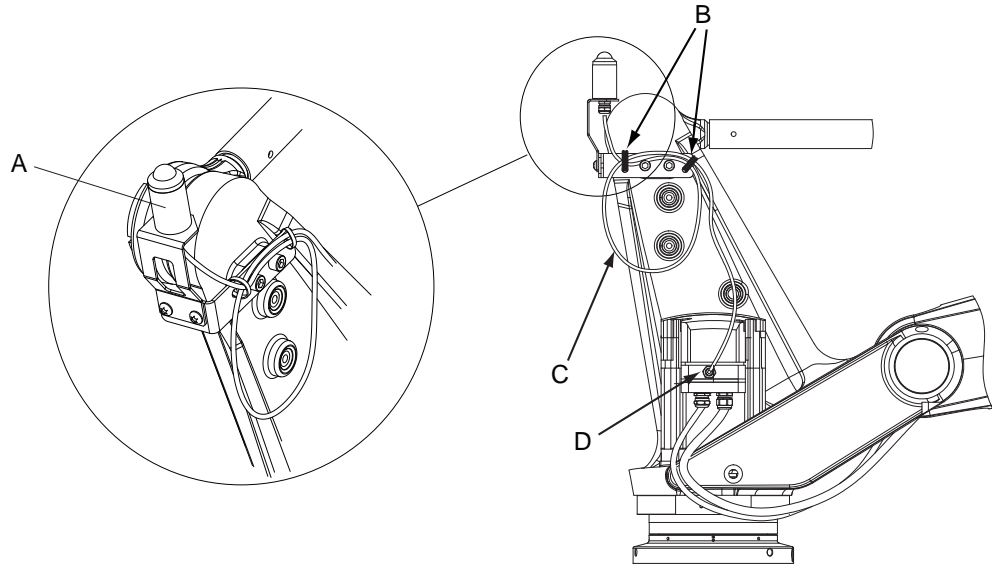

xx0500002466

A	Signal lamp
B	Cable straps, outdoor
C	Cable
D	Connection point to cable gland

Required tools and equipment

Equipment	Article number	Note
Signal lamp kit	See Spare part lists on page 351 .	To be replaced if damage is detected.
Standard toolkit	-	Content is defined in section Standard tools on page 346 .

Inspecting, signal lamp

Use this procedure to inspect the function of the signal lamp.

	Action	Note
1	Inspect that signal lamp is lit when motors are put in operation ("MOTORS ON").	

Continues on next page

	Action	Note
2	 <p>DANGER</p> <p>Turn off all:</p> <ul style="list-style-type: none"> • electric power supply • hydraulic pressure supply • air pressure supply <p>to the robot, before entering the safeguarded space.</p>	
3	<p>If the lamp is not lit, trace the fault by:</p> <ul style="list-style-type: none"> • inspecting whether the signal lamp is broken. If so, replace it. • inspecting cable connections. • measuring the voltage in the connectors of motor axis 6 (=24V). • inspecting the cabling. Replace the cabling if a fault is detected. 	<p>Article number is specified in Required tools and equipment on page 118.</p>

3 Maintenance

3.4.1 Type of lubrication in gearboxes

3.4 Replacement/changing activities

3.4.1 Type of lubrication in gearboxes

Introduction

This section describes where to find information about the type of lubrication, article number and the amount of lubrication in the specific gearbox. It also describes the equipment needed when working with lubrication.

Type and amount of oil in gearboxes

Information about the type of lubrication, article number as well as the amount in the specific gearbox can be found in *Technical reference manual - Lubrication in gearboxes* available for registered users on myABB Business Portal, www.abb.com/myABB.

Location of gearboxes

The figure shows the location of the gearboxes.

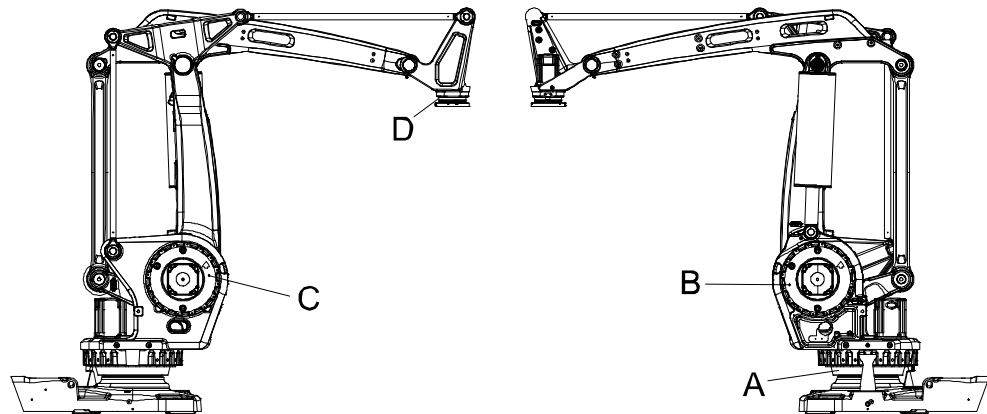

xx0500002467

A	Gearbox, axis 1
B	Gearbox, axis 2
C	Gearbox, axis 3
D	Gearbox, axis 6

Equipment

Equipment	Note
Oil dispenser	Includes pump with outlet pipe. Use the suggested dispenser or a similar one: <ul style="list-style-type: none">Orion OriCan article number 22590 (pneumatic)
Nipple for quick connect fitting, with o-ring	

3.4.2 Changing oil, axis-1 gearbox

Location of oil plugs

The axis-1 gearbox is located between the frame and base. See oil plugs in the following figure.

The oil is drained through a hose, which is located at the rear of the robot base.

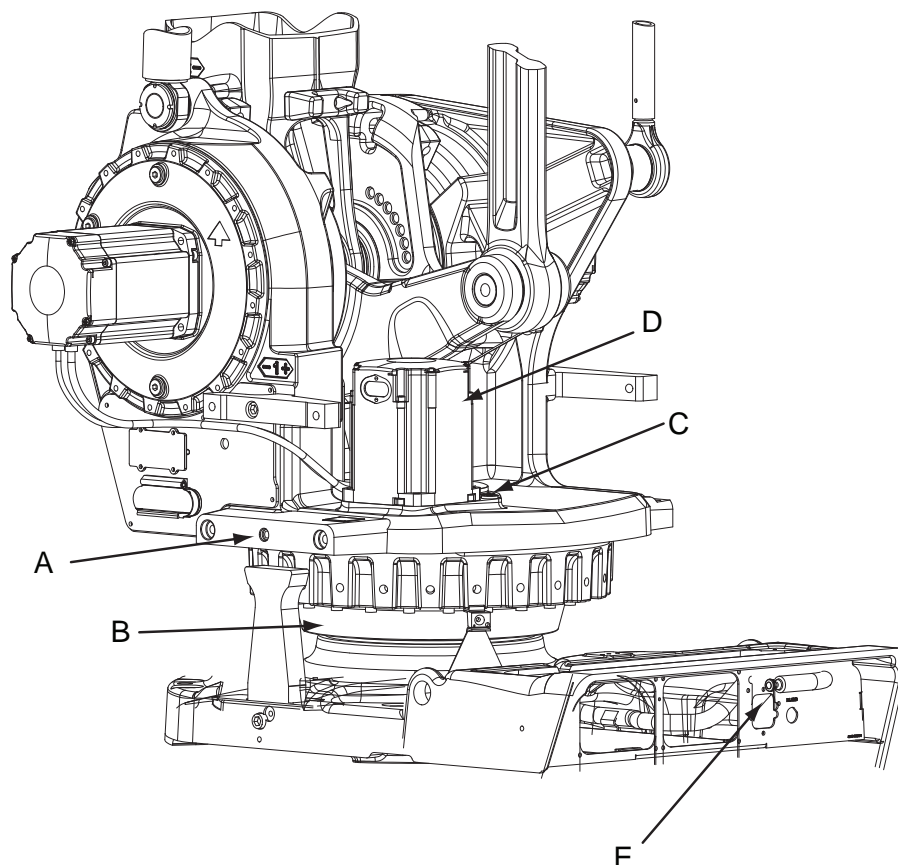

xx0500002479

A	Oil plug, inspection
B	Gearbox axis 1
C	Oil plug, filling
D	Motor, axis 1
E	Drain hose

Required equipment

Equipment, etc.	Art. no.	Amount	Note
Lubricating oil	See <i>Type and amount of oil in gearboxes on page 120.</i>	See <i>Type and amount of oil in gearboxes on page 120.</i>	 Note Do not mix with other oils!
Oil collecting vessel	-		Capacity: 8,000 ml.

Continues on next page

3 Maintenance

3.4.2 Changing oil, axis-1 gearbox

Continued



Equipment, etc.	Art. no.	Amount	Note
Oil exchange equipment	3HAC021745-001		Content is defined in section Special tools on page 347 .
Standard toolkit	-		Content is defined in section Standard tools on page 346 .

Draining oil, axis-1 gearbox



Use this procedure to drain the oil in gearbox axis 1.

When using oil exchange equipment, follow the instructions enclosed with the kit.

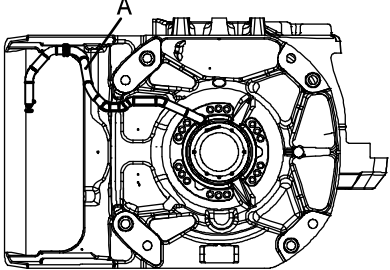
Art. no. for the kit is specified in [Required equipment on page 121](#).



	Action	Note
1	 DANGER Turn off all: <ul style="list-style-type: none"> • electric power supply • hydraulic pressure supply • air pressure supply to the robot, before entering the safeguarded space.	
2	 WARNING Handling gearbox oil involves several safety risks, see Gearbox lubricants (oil or grease) on page 34 .	
3	Remove rear cover on the base by unscrewing its attachment screws.	
4	Pull out the draining hose from the rear of the base.	 <p>xx0200000237</p> <p>The hose is located beneath the base, seen from below. A Oil draining hose</p>
5	Place an oil vessel close to hose end.	Vessel capacity is specified in Required equipment on page 121 .
6	Remove <i>oil plug, filling</i> in order to drain oil quicker!	Shown in figure Location of oil plugs on page 121 .

Continues on next page

	Action	Note
7	<p>Open the hose end and drain the oil into a vessel.</p> <p> CAUTION</p> <p>Drain as much oil as possible.</p>	<p> Note</p> <p>Draining is time-consuming. Elapsed time depends on the temperature of the oil.</p>
8	<p>Close the oil drain hose, and put it back inside the base.</p>	
9	<p>Refit rear cover by securing it with its attachment screws.</p>	

Filling oil, axis-1 gearbox

Use this procedure to fill gearbox axis 1 with oil.

	Action	Note
1	<p> DANGER</p> <p>Turn off all:</p> <ul style="list-style-type: none"> • electric power supply • hydraulic pressure supply • air pressure supply <p>to the robot, before entering the safeguarded space.</p>	
2	<p> WARNING</p> <p>Handling gearbox oil involves several safety risks, see Gearbox lubricants (oil or grease) on page 34.</p>	
3	<p>Open the <i>oil plug, filling</i>.</p>	<p>Shown in figure Location of oil plugs on page 121.</p>
4	<p>Refill the gearbox with clean <i>lubricating oil</i>. The correct oil level is detailed in section Inspecting the oil level in axis-1 gearbox on page 96.</p>	<p>Where to find type of oil and total amount is detailed in Type and amount of oil in gearboxes on page 120.</p>
5	<p>Refit the oil plug, filling.</p>	<p>Tightening torque: 24 Nm.</p>

3 Maintenance

3.4.3 Changing oil, gearbox axes 2 and 3

3.4.3 Changing oil, gearbox axes 2 and 3

Location of oil plugs

Gearboxes, axes 2 and 3, are located in lower arm rotational center, underneath motor attachment.

The figure shows the position of gearbox, axis 2.

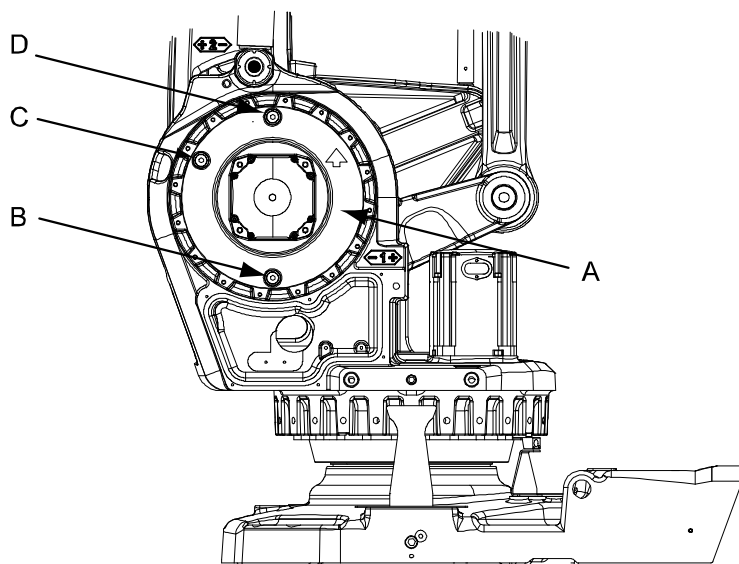

xx0500002482

A	Gearbox axis 2
B	Oil plug, draining
C	Oil plug, filling
D	Ventilation hole plug, gearbox axis 2

Continues on next page

The figure shows position of gearbox, axis 3.

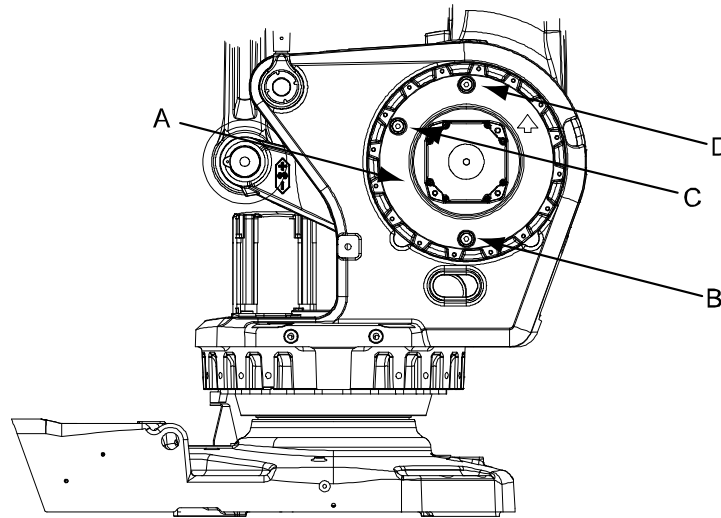

xx0500002483

A	Gearbox, axis 3
B	Oil plug, draining
C	Oil plug, filling
D	Ventilation hole plug, gearbox axis 3

Required equipment

Equipment etc.	Art. no.	Amount	Note
Lubricating oil	See <i>Type and amount of oil in gearboxes on page 120.</i>	See <i>Type and amount of oil in gearboxes on page 120.</i>	 Note Do not mix with other oils!
Oil collecting vessel			Capacity: 6,000 ml
Oil exchange equipment	3HAC021745-001		Content is defined in section <i>Special tools on page 347.</i>
Standard toolkit	-		Content is defined in section <i>Standard tools on page 346.</i>

Continues on next page

3 Maintenance



3.4.3 Changing oil, gearbox axes 2 and 3

Continued

Draining, axes 2 and 3

Use this procedure to drain oil in gearbox axes 2 and 3.



When using oil change equipment, follow the instructions enclosed with kit.

	Action	Note
1	 DANGER Turn off all: <ul style="list-style-type: none"> • electric power supply • hydraulic pressure supply • air pressure supply to the robot, before entering the safeguarded space.	
2	 WARNING Handling gearbox oil involves several safety risks, see Gearbox lubricants (oil or grease) on page 34 .	
3	Remove the <i>ventilation hole plug</i> .	Shown in Location of oil plugs on page 124 .
4	Remove the <i>oil plug, draining</i> , and drain gearbox using a hose with a nipple and an oil collecting vessel.	Shown in Location of oil plugs on page 124 . Vessel capacity is specified in Required equipment on page 125 . Draining is time-consuming. Elapsed time varies depending on the temperature of the oil.
5	Refit the oil plug, draining.	Tightening torque: 24 Nm.

Filling, axes 2 and 3

Use this procedure to fill gearboxes of axes 2 and 3 with oil.

When using oil change equipment, follow the instructions enclosed with kit.

	Action	Note
1	 DANGER Turn off all: <ul style="list-style-type: none"> • electric power supply • hydraulic pressure supply • air pressure supply to the robot, before entering the safeguarded space.	
2	 WARNING Handling gearbox oil involves several safety risks, see Gearbox lubricants (oil or grease) on page 34 .	

Continues on next page

	Action	Note
3	Remove the <i>oil plug, filling</i> . (<i>Ventilation hole plug</i> should also be removed.)	Shown in Location of oil plugs on page 124 . Tightening torque: 24 Nm.
4	Refill gearbox with <i>lubricating oil</i> . The <i>amount of oil</i> to be filled depends on the amount that was previously drained.	Art.no. and total amount are specified in Required equipment on page 125 .
5	Refit <i>oil plug, filling</i> and <i>ventilation hole plug</i> .	Shown in Location of oil plugs on page 124 . Tightening torque: 24 Nm.

3 Maintenance

3.4.4 Changing oil, gearbox axis 6

3.4.4 Changing oil, gearbox axis 6

Location of oil plugs

Gearbox axis 6 is located in the center of the tilt house unit.

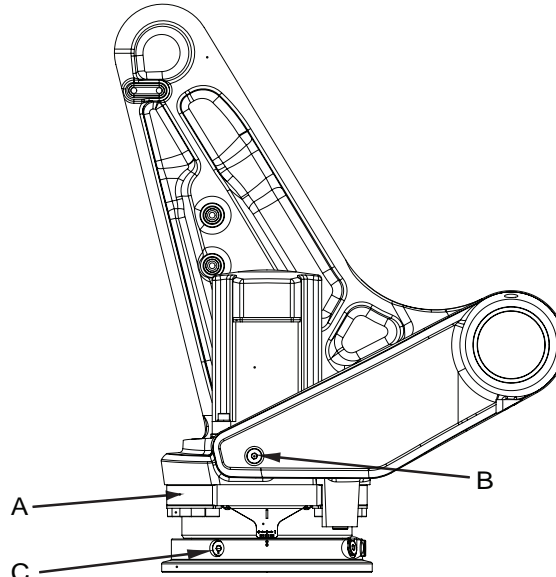

xx0500002484

A	Gearbox, axis 6
B	Oil plug, filling
C	Oil plug, draining

Required equipment

Equipment, etc.	Art. no.	Amount	Note
Lubrication oil	3HAC032140-001	250 ml	Kyodo Yushi TMO 150 Do not mix with other oil types!
Oil exchange equipment	3HAC021745-001		
Oil collecting vessel			Vessel capacity: 400 ml.
Standard toolkit		-	Content is defined in section Standard tools on page 346 .

Draining, oil

Use this procedure to drain oil from gearbox axis 6.

When using oil change equipment, follow the instructions enclosed with kit.

	Action	Note
1	Put tilt house in a suitable position.	

Continues on next page

	Action	Note
2	 DANGER Turn off all: <ul style="list-style-type: none"> • electric power supply • hydraulic pressure supply • air pressure supply to the robot, before entering the safeguarded space.	
3	Drain oil from gearbox into a vessel by removing <i>oil plug, draining</i> . Also remove <i>oil plug, filling</i> .	Shown in figure Location of oil plugs on page 128 . Vessel capacity is specified in Required equipment on page 128 .
4	Refit oil plugs, draining and filling.	Tightening torque: 20 Nm.

Filling, oil

Use this procedure to fill gearbox axis 6 with oil.

When using oil change equipment, follow the instructions enclosed with kit.

	Action	Note
1	 DANGER Turn off all: <ul style="list-style-type: none"> • electric power supply • hydraulic pressure supply • air pressure supply to the robot, before entering the safeguarded space.	
2	Remove the <i>oil plug, filling</i> .	Shown in figure Location of oil plugs on page 128 .
3	Refill the gearbox with <i>lubricating oil</i> . Amount of oil to be refilled depends on the amount that was previously drained. Correct oil level is detailed in section Inspection, oil level axis-6 gearbox on page 102 .	Art. no. and the total amount are specified in Required equipment on page 128 .
4	Refit the oil plug.	Tightening torque: 20 Nm

3 Maintenance

3.4.5 Replacing the SMB battery

3.4.5 Replacing the SMB battery



Note

The battery low alert (38213 **Battery charge low**) is displayed when the battery needs to be replaced. The recommendation to avoid an unsynchronized robot is to keep the power to the controller turned on until the battery is to be replaced.

For a SMB board with 3-pole battery contact (RMU101 3HAC044168-001 or RMU102 3HAC043904-001), the lifetime of a new battery is typically 36 months.

For a SMB board with 2-pole battery contact (DSQC), the typical lifetime of a new battery is 36 months if the robot is powered off 2 days/week or 18 months if the robot is powered off 16 h/day. The lifetime can be extended for longer production breaks with a battery shutdown service routine. See the operating manual for the robot controller for instructions.



WARNING

See [Hazards related to batteries on page 36](#).

Location of SMB battery

The SMB battery (SMB = serial measurement board) is located on the left hand side of the frame as shown in the figure.

Battery pack with a 2-pole battery contact (DSQC)

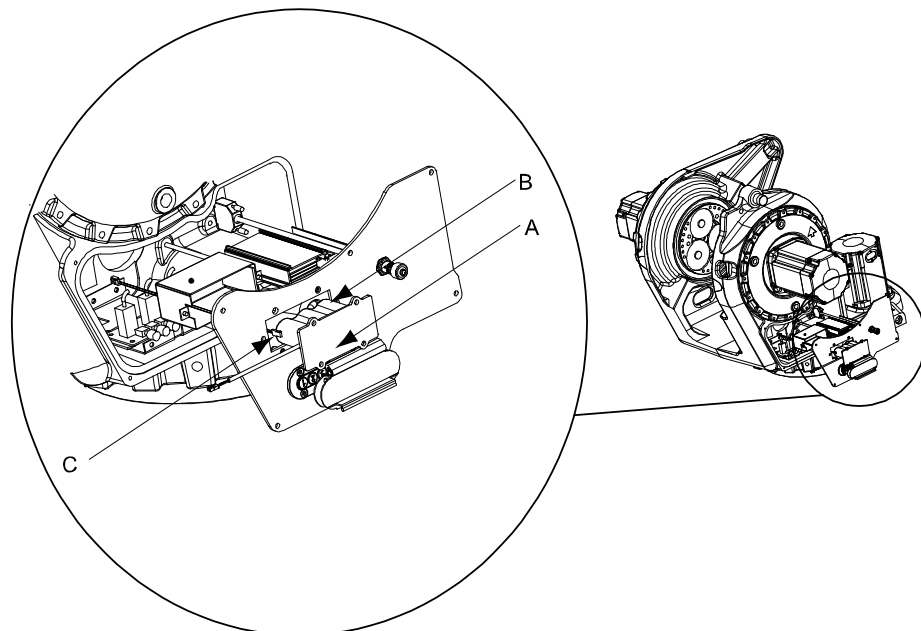

xx0500002486

A	SMB battery cover
B	SMB battery pack
C	Battery cable

Continues on next page

Battery pack with a 3-pole battery contact (RMU)

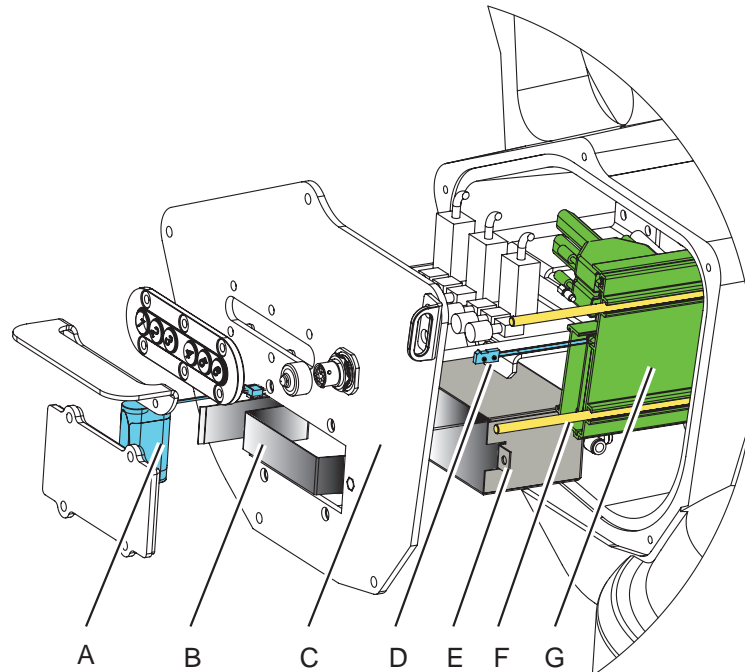

xx1400002574

A	Battery pack RMU
B	Holder for battery
C	SMB cover
D	Battery cable
E	Battery holder
F	Guide pin (2 pcs)
G	SMB unit

Required equipment



Note

There are two variants of SMB units and batteries. One with 2-pole battery contact (DSQC) and one with 3-pole battery contact (RMU). The variant with the 3-pole battery contact has longer lifetime for the battery.

It is important that the SMB unit uses the correct battery. Make sure to order the correct spare parts. Do not exchange battery contacts!

Equipment, etc.	Spare part no.	Note
Battery unit	For spare part no. see: <ul style="list-style-type: none"> Spare part lists on page 351 	Battery includes protection circuits. Only replace with a specified spare part or an ABB-approved equivalent.
Standard toolkit	-	Content is defined in section Standard tools on page 346 .

Continues on next page

3 Maintenance



3.4.5 Replacing the SMB battery

Continued

Equipment, etc.	Spare part no.	Note
Circuit diagram	-	See chapter Circuit diagrams on page 353 .

Removing, battery





Use this procedure to remove the SMB battery.

	Action	Note
1	Move the robot to its calibration position.	This is done in order to facilitate updating of the revolution counter.
2	 DANGER Turn off all: <ul style="list-style-type: none"> • electric power supply • hydraulic pressure supply • air pressure supply to the robot, before entering the safeguarded space.	
3	 ELECTROSTATIC DISCHARGE (ESD) The unit is sensitive to ESD. Before handling the unit please read the safety information in the section The unit is sensitive to ESD on page 49	
4	Remove the <i>SMB battery cover</i> by unscrewing the attachment screws.  CAUTION Clean cover from metal residues before opening. Metal residues can cause shortage on the boards which can result in hazardous failures.	Shown in figure Location of SMB battery on page 130 .
5	Pull out the battery and disconnect the <i>battery cable</i> .	Shown in figure Location of SMB battery on page 130 .
6	Remove the <i>SMB battery</i> . Battery includes protection circuits. Only replace with a specified spare part or with an ABB- approved equivalent.	Shown in figure Location of SMB battery on page 130 .

Continues on next page

Refitting, battery

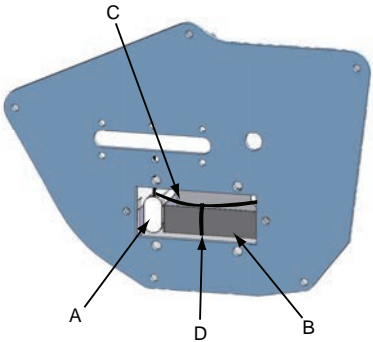
Use this procedure to refit the SMB battery.

	Action	Note
1	 DANGER Turn off all: <ul style="list-style-type: none"> • electric power supply • hydraulic pressure supply • air pressure supply to the robot, before entering the safeguarded space.	
2	 ELECTROSTATIC DISCHARGE (ESD) The unit is sensitive to ESD. Before handling the unit please read the safety information in the section The unit is sensitive to ESD on page 49	
3	Reconnect the <i>battery cable</i> and install the battery pack into the SMB/battery recess.  Note RMU batteries are installed together with a battery holder to be properly secured inside the recess. See figure. Strap the battery cable to the holder.	Art. no. is specified in Required equipment on page 131 . Shown in figure Location of SMB battery on page 130 .  xx1300000307 A Battery pack RMU B Battery holder C Battery cable D Strap
4	Secure the <i>SMB battery cover</i> with its attachment screws.	Shown in figure Location of SMB battery on page 130 .
5	Update the revolution counters.	Detailed in chapter Calibration - section Updating revolution counters on IRC5 robots on page 308 .
6	 DANGER Make sure all safety requirements are met when performing the first test run.	

3 Maintenance

3.5.1 Lubricating balancing device bearings and piston rod

3.5 Lubrication activities

3.5.1 Lubricating balancing device bearings and piston rod

Overview

This procedure details how to lubricate the balancing device's bearings and piston rod.

Location of bearings and piston rod

This figure shows the location of bearings and piston rod.

Note! Balancing device must be fitted on robot when lubricating bearings!

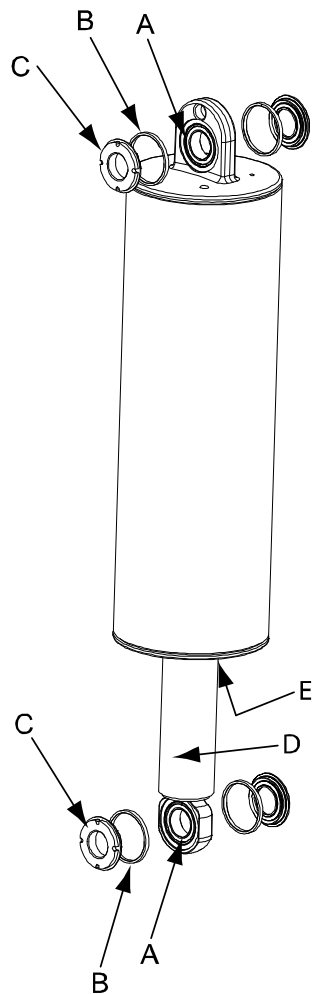

xx0500002489

A	Ear (bearing located inside)
B	Support washer
C	Lock nut
D	Piston rod
E	Guide ring (not visible in this view)

Continues on next page



3.5.1 Lubricating balancing device bearings and piston rod *Continued*

Required equipment

Equipment	Art. no.	Note
Lubrication tool	3HAC5222-2	
Bearing grease	3HAC042536-001	Equivalent: <ul style="list-style-type: none"> • Shell Gadus S2
Cleaning agent	-	Isopropanol
Piston rod grease	-	Choose any of following equivalents: <ul style="list-style-type: none"> • Shell: SRS Grease 4000 • Preem: Novatex Heavy EP 2 • Castrol: Entrenadfett • Statoil: Uniway 2X2N
Locking liquid	-	Loctite 243
Standard toolkit	-	Content is defined in section Standard tools on page 346 .
Other tools and procedures may be required. See references to these procedures in the step-by-step instructions below.		These procedures include references to the tools required.

Lubricating, bearings

Use this procedure to lubricate the balancing device bearings.

	Action	Note
1	Move axis 2 to calibration position.	
2	 DANGER Turn off all: <ul style="list-style-type: none"> • electric power supply • hydraulic pressure supply • air pressure supply to the robot, before entering the safeguarded space.	
3	Remove the locknut.	Be careful not to loose the support washer in the process.
4	Fit the lubricating tool. It should be tightened to the bottom, by hand only.	
5	Grease through nipple on the lubricating tool.	
6	Continue filling grease until clean grease exudes behind the inner sealing ring. Repeat this procedure at the other bearing!	
7	Remove the lubricating tool and clean the threads on the shaft ends of grease.	Also clean of old grease on the inner side!
8	Apply some grease to the support washers.	
9	 Note Apply locking liquid on the lock nuts (KM10). Do not apply locking liquid on the shafts!	Tightening torque on lock nuts: <ul style="list-style-type: none"> • 120 Nm

Continues on next page

3 Maintenance

3.5.1 Lubricating balancing device bearings and piston rod

Continued

	Action	Note
10	Check play between support washer and bearings at both bearings.	Minimum play: <ul style="list-style-type: none">• 0.1 mm

Lubricating, piston rod

Use this procedure to lubricate the balancing device piston rod.

	Action	Note
1	Position axis 2 so that the balancing device is horizontal and the piston rod is extended to the greatest extent possible.	
2	 DANGER Turn off all: <ul style="list-style-type: none">• electric power supply• hydraulic pressure supply• air pressure supply to the robot, before entering the safeguarded space.	
3	Clean piston rod with isopropanol before applying new grease.	
4	Apply new grease.	Type of grease is specified in Required equipment on page 135 .

3.6 Cleaning activities

3.6.1 Cleaning the IRB 660



DANGER

Turn off all:

- electric power supply
- hydraulic pressure supply
- air pressure supply

to the robot, before entering the safeguarded space.

General

To secure high uptime it is important that the IRB 660 is cleaned regularly. The frequency of cleaning depends on the environment in which the product works. Different cleaning methods are allowed depending on the type of protection of the IRB 660.



Note

Always verify the protection type of the robot before cleaning.

Oil spills

Oil spills from gearboxes

Use the following procedure if any oil spills are detected that can be suspected to originate from a gearbox.

- 1 Inspect that the oil level in the suspected gearbox is according to the recommendations, see [Inspection activities on page 96](#).
- 2 Write down the oil level.
- 3 Inspect the oil level again after, for example, 6 months.
- 4 If the oil level is decreased then replace the gearbox.

Special cleaning considerations

This section specifies some special considerations when cleaning the robot.

- Always use cleaning equipment as specified. Any other cleaning equipment may shorten the life of the robot.
- Always check that all protective covers are fitted to the robot before cleaning.
- Never point the water jet at connectors, joints, sealings, or gaskets.
- Do not use compressed air to clean the robot.
- Never use solvents that are not approved by ABB to clean the robot.
- Do not spray from a distance closer than 0.4 m.
- Do not remove any covers or other protective devices before cleaning the robot.

Continues on next page

3 Maintenance

3.6.1 Cleaning the IRB 660

Continued

Cleaning methods

The following table defines what cleaning methods are allowed depending on the protection type.

Protection type	Cleaning method			
	Vacuum cleaner	Wipe with cloth	Rinse with water	High pressure water or steam
Standard	Yes	Yes. With light cleaning detergent.	Yes. It is highly recommended that the water contains a rust-prevention solution and that the manipulator is dried afterwards.	No

Cleaning with water and steam

Instructions for rinsing with water

ABB robots with protection types *Standard*, *Foundry Plus*, *Wash*, or *Foundry Prime* can be cleaned by rinsing with water (water cleaner).¹

The following list defines the prerequisites:

- Maximum water pressure at the nozzle: 700 kN/m² (7 bar)¹
- Fan jet nozzle should be used, min. 45° spread
- Minimum distance from nozzle to encapsulation: 0.4 meters
- Maximum flow: 20 liters/min¹

¹ Typical tap water pressure and flow

Cables

Movable cables need to be able to move freely:

- Remove waste material, such as sand, dust and chips, if it prevents cable movement.
- Clean the cables if they have a crusty surface, for example from dry release agents.

¹ See [Cleaning methods on page 138](#) for exceptions.

4 Repair

4.1 Introduction

Structure of this chapter

This chapter describes repair activities for the IRB 660. Each procedure contains the information required to perform the activity, for example spare parts numbers, required special tools, and materials.



WARNING

Repair activities not described in this chapter must only be carried out by ABB.

Report replaced units



Note

When replacing a part on the IRB 660, report to your local ABB the serial number, the article number, and the revision of both the replaced unit and the replacement unit.

This is particularly important for safety equipment to maintain the safety integrity of the installation.

Safety information

Make sure to read through the chapter [Safety on page 19](#) before commencing any service work.



Note

If the IRB 660 is connected to power, always make sure that the IRB 660 is connected to protective earth and a residual current device (RCD) before starting any repair work.

For more information see:

- *Product manual - OmniCore V250XT*
- *Product manual - IRC5*
- *Product manual - IRC5 Panel Mounted Controller*

4 Repair

4.2.1 Performing a leak-down test

4.2 General procedures

4.2.1 Performing a leak-down test

When to perform a leak-down test

After refitting any motor and gearbox, the integrity of all seals enclosing the gearbox oil must be tested. This is done in a leak-down test.

Required equipment

Equipment, etc.	Article number	Note
Leak-down tester	-	
Leak detection spray	-	

Performing a leak-down test

	Action	Note
1	Finish the refitting procedure of the motor or gear in question.	
2	Remove the upper oil plug on the gear and replace it with the leak-down tester. Regulators, which are included in the leak-down test, may be required.	
3	Use caution, apply compressed air and raise the pressure with the knob until the correct value is shown on the manometer.  CAUTION The pressure must under no circumstance be higher than 0.25 bar (20-25 kPa). Also during the time when the pressure is raised.	Correct value: 0.2-0.25 bar (20-25 kPa)
4	Disconnect the compressed air supply.	
5	Wait for approximately 8-10 minutes and make sure that no pressure loss occurs.	If the compressed air is significantly colder or warmer than the gearbox to be tested, a slight pressure increase or decrease may occur. This is quite normal.
6	If any pressure drop occurred, then localize the leak as described in step 7. If no pressure drop occurred, then remove the leak-down tester and refit the oil plug. The test is complete.	
7	Spray any suspected leak areas with the leak detection spray. Bubbles indicate a leak.	
8	When the leak has been localized, take the necessary measures to correct the leak.	

4.2.2 Mounting instructions for bearings

General

This section describes how to mount and grease different types of bearings on the robot.

Equipment

Equipment, etc.	Article number	Note
Grease	3HAC042536-001	Shell Gadus S2 Used to grease the bearings, if not specified otherwise.

Assembly of all bearings

Attend to the following instructions while mounting a bearing on the robot.

	Action	Note
1	To avoid contamination, let a new bearing remain in its wrapping until it is time for fitting.	
2	Ensure that the parts included in the bearing fitting are free from burrs, grinding waste, and other contamination. Cast components must be free of foundry sand.	
3	Bearing rings, inner rings, and roller elements must not be subjected to direct impact. The roller elements must not be exposed to any stresses during the assembly work.	

Assembly of tapered bearings

Follow the preceding instructions for the assembly of the bearings when mounting a tapered bearing on the robot.

In addition to those instructions, the following procedure must be carried out to enable the roller elements to adjust to the correct position against the race flange.

	Action	Note
1	Tension the bearing gradually until the recommended pre-tension is achieved.  Note The roller elements must be rotated a specified number of turns before pre-tensioning is carried out and also rotated during the pre-tensioning sequence.	
2	Make sure the bearing is properly aligned as this will directly affect the durability of the bearing.	

Greasing of bearings



Note

This instruction is not valid for solid oil bearings.

Continues on next page

4 Repair

4.2.2 Mounting instructions for bearings

Continued

The bearings must be greased after assembly according to the following instructions:

- The bearings must not be completely filled with grease. However, if space is available beside the bearing fitting, the bearing may be totally filled with grease when mounted, as excessive grease will be pressed out from the bearing when the robot is started.
- During operation, the bearing should be filled to 70-80% of the available volume.
- Ensure that grease is handled and stored properly to avoid contamination.

Grease the different types of bearings as following description:

- *Grooved ball bearings* must be filled with grease from both sides.
- *Tapered roller bearings* and axial needle bearings must be greased in the split condition.

4.2.3 Mounting instructions for sealings

General

This section describes how to mount different types of sealings.

Equipment

Consumable	Article number	Note
Grease	3HAC042536-001	Shell Gadus S2

Rotating sealings

The procedure below describes how to fit rotating sealings.



CAUTION

Please observe the following before commencing any assembly of sealings:

- Protect the sealing during transport and mounting, especially the main lip.
- Keep the sealing in its original wrappings or protect it well before actual mounting.
- The fitting of sealings and gears must be carried out on clean workbenches.
- Use a protective sleeve for the main lip during mounting, when sliding over threads, keyways or other sharp edges.

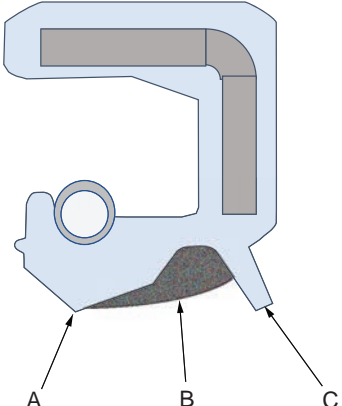
Action	Note
1 Check the sealing to ensure that: <ul style="list-style-type: none"> • The sealing is of the correct type. • There is no damage on the main lip. 	
2 Inspect the shaft surface before mounting. If scratches or damage are found, the shaft must be replaced since it may result in future leakage. Do not try to grind or polish the shaft surface to get rid of the defect.	
3 Lubricate the sealing with grease just before fitting. (Not too early - there is a risk of dirt and foreign particles adhering to the sealing.) Fill 2/3 of the space between the dust lip and the main lip with grease. If the sealing is without dust lip, just lubricate the main lip with a thin layer of grease.	Article number is specified in Equipment on page 143 .  xx2000000071 A Main lip B Grease C Dust lip

Continues on next page

4 Repair

4.2.3 Mounting instructions for sealings

Continued

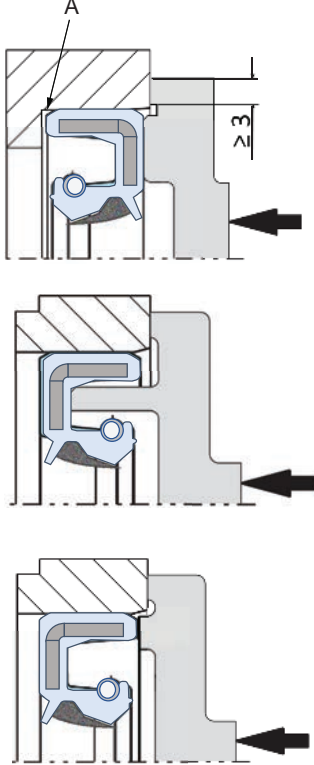
	Action	Note
4	<p>Mount the sealing correctly with a mounting tool. Never hammer directly on the sealing as this may result in leakage.</p>	 <p>xx2000000072</p> <p>A Gap</p>

Flange sealings and static sealings

The following procedure describes how to fit flange sealings and static sealings.

	Action
1	<p>Check the flange surfaces. They must be even and free from pores. It is easy to check flatness using a gauge on the fastened joint (without sealing compound). If the flange surfaces are defective, the parts may not be used because leakage could occur.</p>
2	<p>Clean the surfaces properly in accordance with the recommendations of ABB.</p>
3	<p>Distribute the sealing compound evenly over the surface, preferably with a brush.</p>
4	<p>Tighten the screws evenly when fastening the flange joint.</p>

O-rings

The following procedure describes how to fit o-rings.

	Action	Note
1	<p>Ensure that the correct o-ring size is used.</p>	
2	<p>Check the o-ring for surface defects, burrs, shape accuracy, or deformation.</p>	<p>Defective o-rings, including damaged or deformed o-rings, may not be used.</p>

Continues on next page

	Action	Note
3	Check the o-ring grooves. The grooves must be geometrically correct and should be free of pores and contamination.	
4	Lubricate the o-ring with grease.	
5	Tighten the screws evenly while assembling.	
6	Check that the o-ring is not squashed outside the o-ring groove.	

4 Repair

4.2.4 Cut the paint or surface on the robot before replacing parts

4.2.4 Cut the paint or surface on the robot before replacing parts

General

Follow the procedures in this section whenever breaking the paint of the robot during replacement of parts.

Required equipment

Equipment	Spare parts	Note
Cleaning agent		Ethanol
Knife		
Lint free cloth		
Touch up paint Standard/Foundry Plus	3HAC067974-001	Graphite White
Touch up paint Standard/Foundry Plus	3HAC037052-001	ABB Orange

Removing

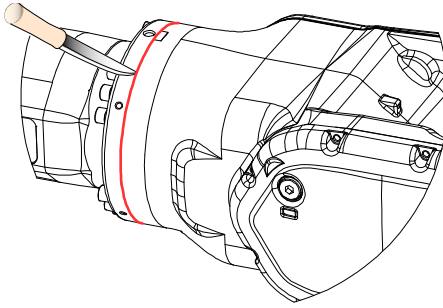
Action	Description
1 Cut the paint with a knife in the joint between the part that will be removed and the structure, to avoid that the paint cracks.	 xx0900000121
2 Carefully grind the paint edge that is left on the structure to a smooth surface.	

4.2.5 The brake release buttons may be jammed after service work

4.2.5 The brake release buttons may be jammed after service work

Description

The brake release unit has push-buttons for the brake release of each axis motor. When service work is performed inside the SMB recess that includes removal and refitting of the brake release unit, the brake release buttons may be jammed after refitting.

**DANGER**

If the power is turned on while a brake release button is jammed in depressed position, the affected motor brake is released. This may cause serious personal injuries and damage to the robot.

Elimination

To eliminate the danger after service work has been performed inside the SMB recess, follow the procedure below.

	Action
1	Make sure the power is turned off.
2	Remove the push-button guard, if necessary.
3	Verify that the push-buttons of the brake release unit are working by pressing them down, one by one. Make sure none of the buttons are jammed in the tube.
4	If a button gets jammed in the depressed position, the alignment of the brake release unit must be adjusted so that the buttons can move freely in their tubes.

4 Repair

4.3.1 Replacing cable harness, lower end (axes 1-3)

4.3 Complete robot

4.3.1 Replacing cable harness, lower end (axes 1-3)

Overview

The cable harness 1-6 is undivided.

How to replace the cable harness is described in two steps - lower end (axes 1-3) and upper end (axis 6). This procedure describes how to replace the lower end of the cable harness. How to replace the upper end can be found in section [Replacing the cable harness, upper end \(incl. axis 6\) on page 156](#).

Location of cable harness - lower end (axes 1-3)

The cable harness, lower end (axes 1-3) is located throughout the base, frame and lower arm as shown in the figure.

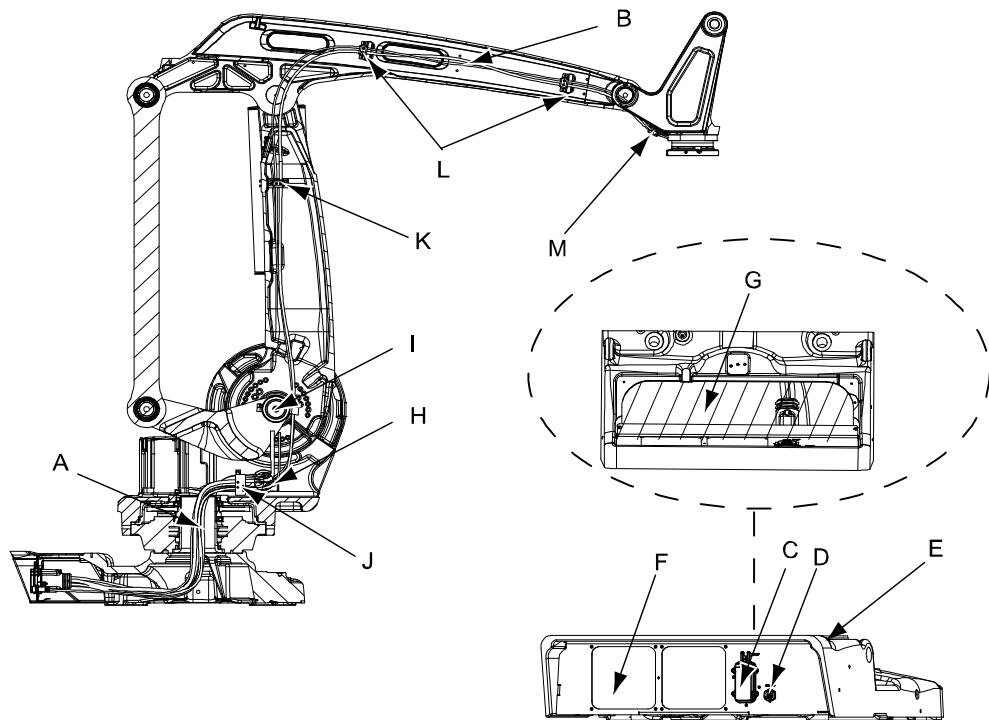

xx0600002608

A	Cable harness, lower end
B	Cable harness, upper end
C	Connector R1.MP
D	Connector R1.SMB
E	Attachment point for earth lug
F	Cover plate
G	Rear cover plate
H	Cable gland, SMB
I	Cable guide, axis 2

Continues on next page

4.3.1 Replacing cable harness, lower end (axes 1-3)

Continued

J	Metal clamp, frame
K	Metal clamp, lower arm
L	Metal clamp, upper arm
M	Metal clamp, tilthouse

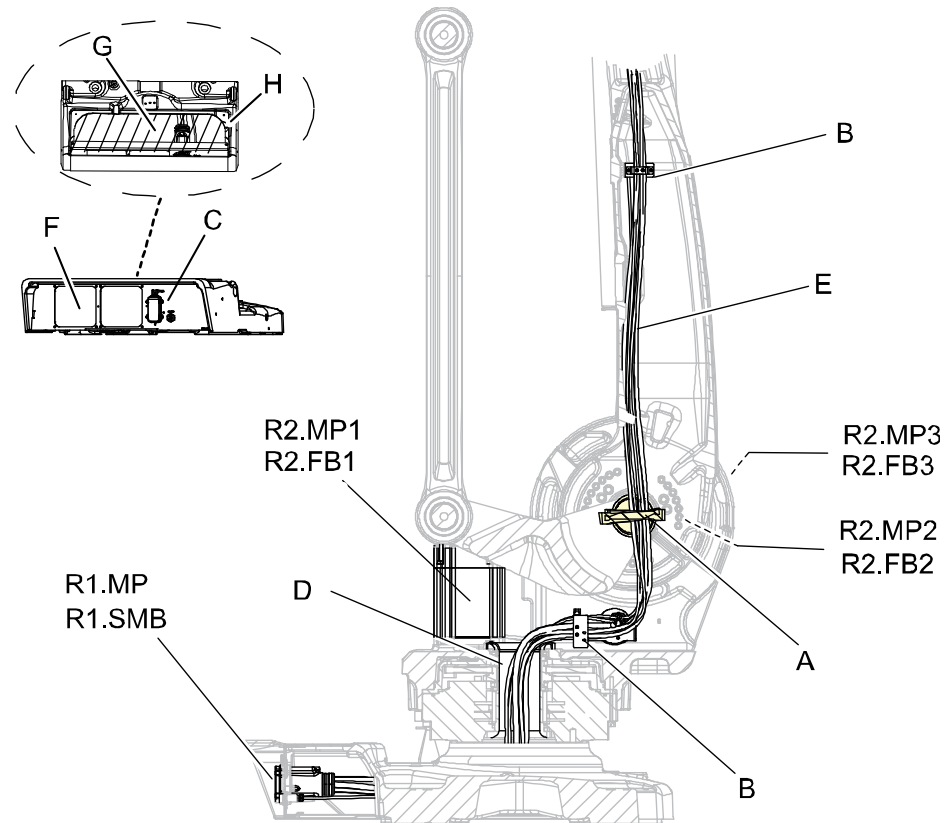

xx070000070

A	Cable guide, axis 2
B	Metal clamp
C	Connector at base
D	Cable guide, axis 1
E	Cable harness, axes 1-6
F	Cover plate
G	Rear cover plate
H	Attachment point for earth lug

Continues on next page

4 Repair

4.3.1 Replacing cable harness, lower end (axes 1-3)

Continued

The motors axes 2-3 are located on either side of the robot as shown in the figure below.

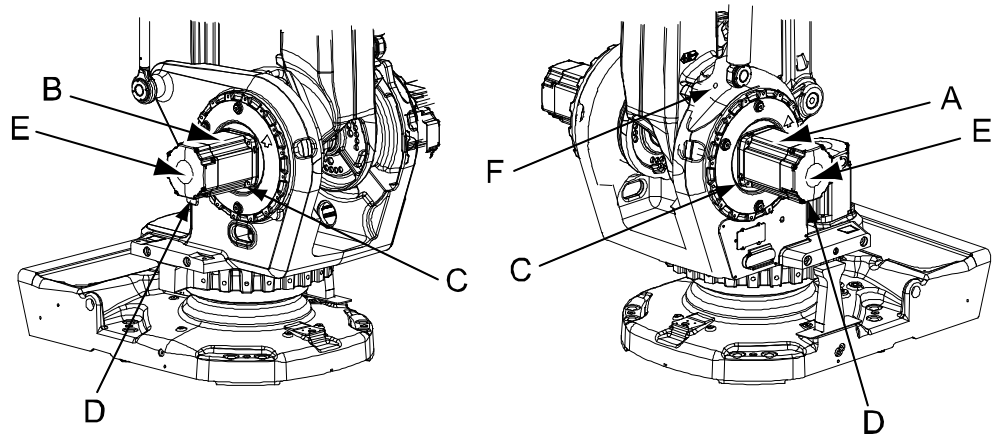

xx0600002599

A	Motor, axis 2
B	Motor, axis 3
C	Motor attachment screws and washers
D	Cable gland cover (located on the lower side of the motor)
E	Motor cover

Required equipment

Equipment, etc.	Art.no.	Note
Cable harness 1-6	For spare part no. see: • Spare part lists on page 351	
Gasket	3HAC3537-1	Motor, axes 1-3 Replace if damaged.
Standard toolkit	-	The content is defined in the section Standard tools on page 346 .
Other tools and procedures may be required. See references to these procedures in the step-by-step instructions below.	-	These procedures include references to the tools required.
Circuit diagram	-	See Circuit diagrams on page 353 .

Removing the cable harness - lower end (axes 1-3)

Use this procedure to remove the cable harness, lower end (axes 1-3).

	Action	Note
1	Move the robot to the calibration position.	This is done in order to facilitate updating of the revolution counter.

Continues on next page

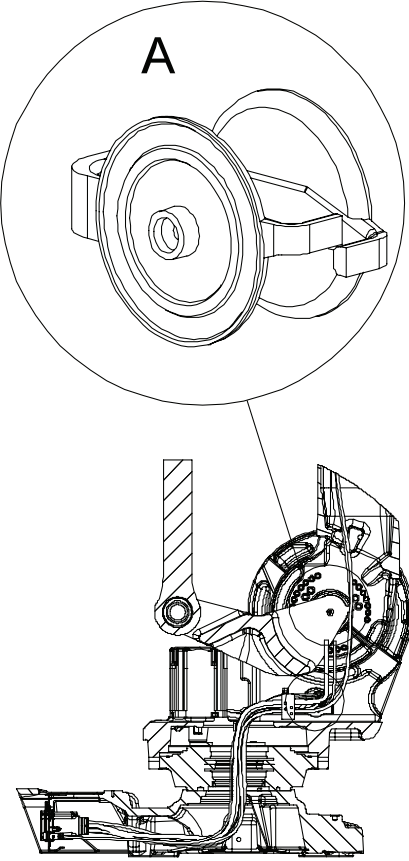

	Action	Note
2	 DANGER Turn off all: <ul style="list-style-type: none"> • electric power supply • hydraulic pressure supply • air pressure supply to the robot, before entering the robot working area.	
3	Remove the <i>rear cover plate</i> from the robot by removing its attachment screws.	Shown in <i>Location of cable harness - lower end (axes 1-3) on page 148.</i>
4	Disconnect the <i>earth cable</i> .	Shown in <i>Location of cable harness - lower end (axes 1-3) on page 148.</i>
5	Disconnect the connectors <i>R1.MP</i> and <i>R1.SMB</i> .	See the figure <i>Location of cable harness - lower end (axes 1-3) on page 148.</i>
6	Unscrew the screws of the <i>cable guide axis 2</i> inside the lower arm and loosen the cable guide.	 <p data-bbox="1023 1733 1129 1749">xx0600002698</p> <ul style="list-style-type: none"> • A: Cable guide ax 2
7	Unscrew the screws in the <i>metal clamps</i> holding the cable harness in the frame and lower arm.	Shown in <i>Location of cable harness - lower end (axes 1-3) on page 148.</i>
8	Unscrew the screws of the motor covers for axes 1, 2 and 3 and lift away the covers. This is done in order to reach the motor connectors.	

Continues on next page

4 Repair

4.3.1 Replacing cable harness, lower end (axes 1-3)

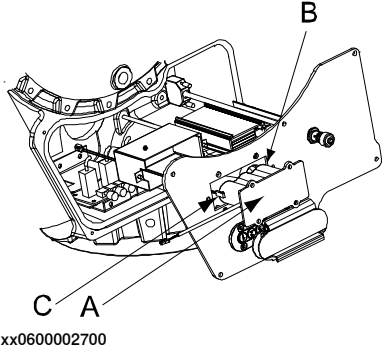
Continued

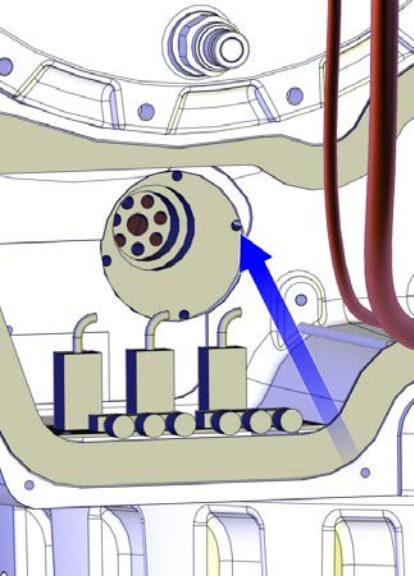
	Action	Note
9	Disconnect all connectors at motors for axes 1, 2 and 3.	See sections: <ul style="list-style-type: none"> • Replacing motor, axis 1 on page 249 • Replacing motors, axes 2 and 3 on page 256
10	Open the SMB cover carefully.	
11	Disconnect connector R1.G on the <i>battery cable</i> between the battery and the SMB unit.  Note This causes a necessary updating of the revolution counter after refitting!	
12	Disconnect connectors R2.SMB, R1.SMB1-3, R1.SMB6 from the SMB unit.	
13	Disconnect X8, X9 and X10 from the brake release unit.	
14	Remove the SMB cover and put somewhere safe.	
15	Unscrew the screws for the <i>cable gland SMB</i> from inside the SMB recess and lift the cable gland out. Perform this removal with care, in order not to damage any of the components inside the SMB recess.	

Continues on next page

4.3.1 Replacing cable harness, lower end (axes 1-3)

Continued

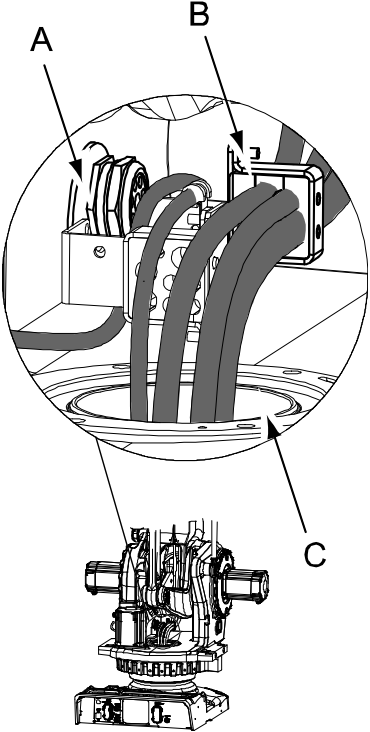
	Action	Note
16	Gently pull the cable harness out from the base through the <i>cable guide</i> , axis 1 and frame.	 <p>xx0600002699</p>
17	Continue removing the cable harness in the upper arm.	See section Replacing the cable harness, upper end (incl. axis 6) on page 156 .

Refitting, cable harness - lower end (axes 1-3)

Use this procedure to refit the cable harness, lower end (axes 1-3).

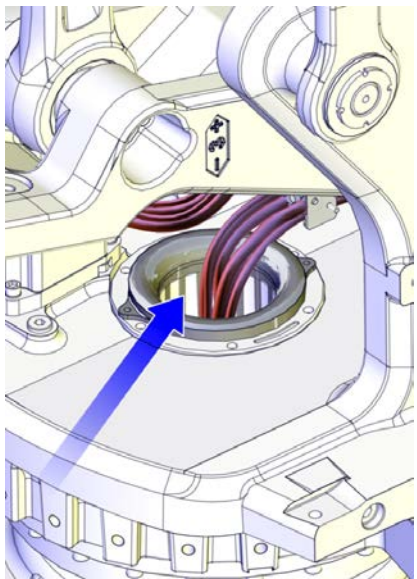
	Action	Note
1	<p>Push the cable harness and connectors down through the cable guide axis 1 in the center of the frame.</p> <p> CAUTION</p> <p>Make sure the cables are not twisted with each other or with customer harness (if any)!</p>	 <p>xx1000001331</p>

Continues on next page



4 Repair

4.3.1 Replacing cable harness, lower end (axes 1-3)

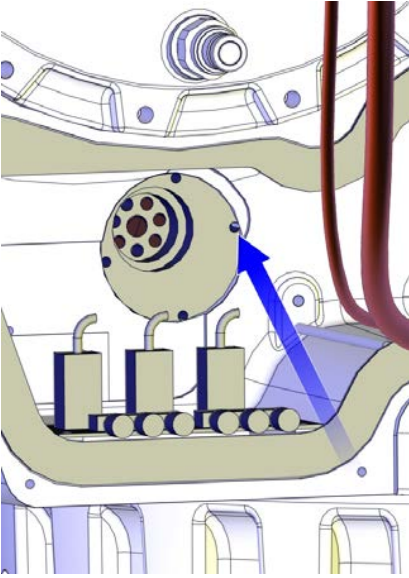
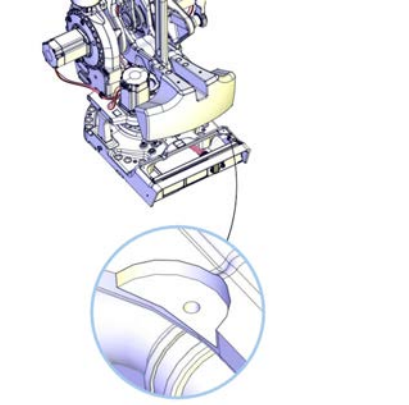
Continued

	Action	Note
2	<p>Pull out the cables and connectors of the SMB unit through the frame and refit the <i>cable gland</i> with its <i>attachment screws</i> from inside the SMB recess.</p> <p>Perform this refitting with care, in order not to damage any of the components inside the SMB recess.</p>	 <p>xx1000001330</p>
3	<p>Reconnect connectors <i>R1.MP</i> and <i>R1.SMB</i> at the robot base.</p>	<p>Tightening torque for R1.SMB: 10 Nm.</p> <p>Attachment points are shown in the figure Location of cable harness - lower end (axes 1-3) on page 148.</p>
4	<p>Reconnect the <i>earth cable</i>.</p>	 <p>xx1000001314</p>
5	<p>Refit the <i>rear cover plate</i> to the robot base with its attachment screws.</p>	<p>Shown in Location of cable harness - lower end (axes 1-3) on page 148.</p>
6	<p>Reconnect all connectors at <i>motors axes 1, 2 and 3</i> and refit the motor covers.</p>	<p>See sections:</p> <ul style="list-style-type: none"> • Replacing motor, axis 1 on page 249 • Replacing motors, axes 2 and 3 on page 256
7	<p>Reconnect connectors R2.SMB, R1.SMB1-3, R1.SMB6 of the SMB unit.</p> <p>Reconnect X8, X9 and X10 to the brake release unit.</p> <p>Reconnect R1.G.</p>	

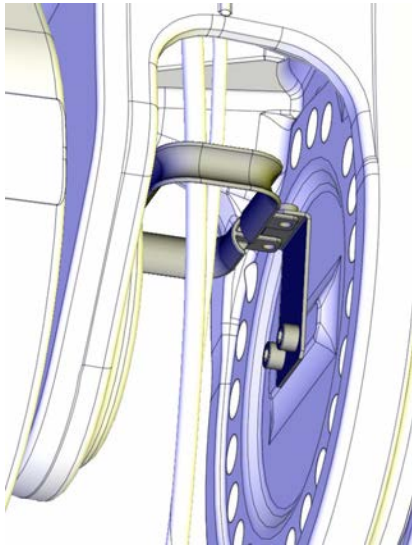
Continues on next page

	Action	Note
8	Secure the <i>SMB</i> cover with its attachment screws. If cabling is used for 7th axis (option), refit the connector R2.FB7 to the SMB cover and tighten with 6 Nm.	
9	 WARNING Before continuing any service work, please observe the safety information in section The brake release buttons may be jammed after service work on page 147.	
10	Push the cable harness up through the lower arm.	
11	Refit the <i>metal clamps</i> holding the cable harness in the frame and lower arm with its attachment screws.	Shown in Location of cable harness - lower end (axes 1-3) on page 148.
12	Refit the <i>cable guide</i> , axis 2.	 <p data-bbox="1023 1420 1134 1435">xx1100000157</p>
13	Continue refitting the cable harness in the upper arm.	See section Replacing the cable harness, upper end (incl. axis 6) on page 156.
14	Make an overall inspection of the installed cable harness.	See Inspecting, cable harness on page 107.
15	Update the revolution counter!	See section Updating revolution counters on IRC5 robots on page 308.
16	 DANGER Make sure all safety requirements are met when performing the first test run.	

4 Repair

4.3.2 Replacing the cable harness, upper end (incl. axis 6)

4.3.2 Replacing the cable harness, upper end (incl. axis 6)

Overview

Replacement of the cable harness is detailed in two steps - lower end (axes 1-3) and upper end. The procedure below details replacement of the cable harness in the upper end (incl. axis 6). The procedure for replacing the lower end (axis 1-3) is detailed in section [Replacing cable harness, lower end \(axes 1-3\) on page 148](#).

Location of cable harness, upper end

The upper end of the cable harness is located as shown in the figure.

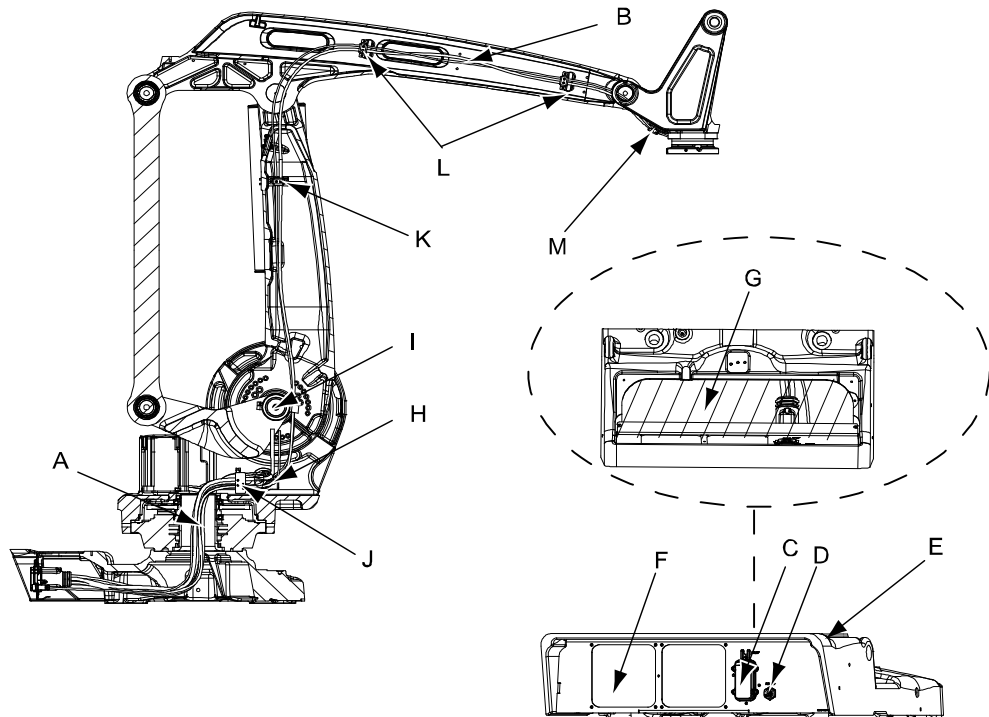

xx0600002608

A	Cable harness, lower end
B	Cable harness, upper end
C	Connector R1.MP
D	Connector R1.SMB
E	Attachment point for earth lug
F	Cover plate
G	Rear cover plate
H	Cable gland, SMB
I	Cable guide, axis 2
J	Metal clamp, frame
K	Metal clamp, lower arm
L	Metal clamp, upper arm

Continues on next page

4.3.2 Replacing the cable harness, upper end (incl. axis 6)

Continued

M	Metal clamp, tilthouse
---	------------------------

The motor axis 6 is located as shown in the figure below.

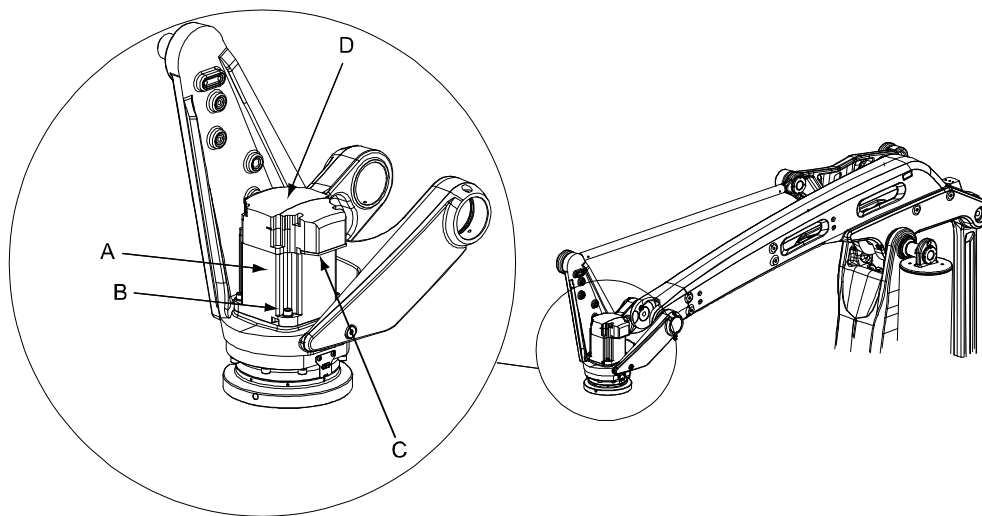

xx0600002600

A	Motor, axis 6
B	Attachment screws and washers
C	Cable gland cover
D	Motor cover

Required equipment

Equipment, etc	Art.no.	Note
Cable harness, 1-6	For spare part no. see: • Spare part lists on page 351	
Gasket	-	Motor, axis 6
Standard toolkit	-	Content is defined in section Standard tools on page 346 .
Other tools and procedures may be required. See references to these procedures in the step-by-step instructions below.		These procedures include references to the tools required.
Circuit diagram	See chapter Circuit diagrams on page 353 .	

Removing cable harness, upper end (incl. axis 6)

Use this procedure to remove the cable harness, upper arm (incl. axis 6).



	Action	Note
1	Move the robot to the calibration position.	This is done in order to facilitate updating of the revolution counter.

Continues on next page

4 Repair

4.3.2 Replacing the cable harness, upper end (incl. axis 6)

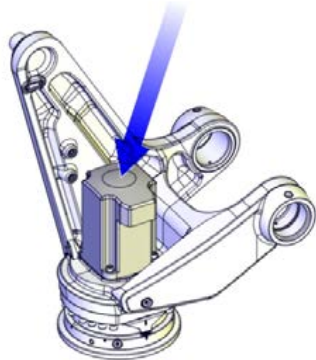
Continued

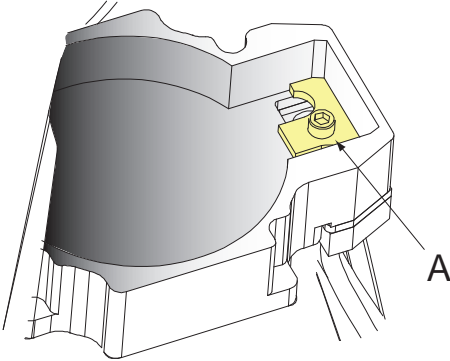
	Action	Note
2	<p> DANGER</p> <p>Turn off all:</p> <ul style="list-style-type: none"> • electric power supply • hydraulic pressure supply • air pressure supply <p>to the robot, before entering the robot working area.</p>	
3	<p>If the complete cable harness is being replaced, start removal by removing the <i>cable harness, lower end</i>.</p>	<p>Detailed in section Replacing cable harness, lower end (axes 1-3) on page 148.</p>
4	<p>Remove the axis 6 motor cover by removing its attachment screws, in order to reach the connectors.</p>	 <p>xx1000001106</p>
	<p>Remove the <i>cable gland cover</i> at the cable exit by unscrewing its <i>attachment screw</i> on the inside.</p> <p> Note</p> <p>Make sure the gasket is not damaged!</p>	 <p>xx0600002694</p> <ul style="list-style-type: none"> • A: Screw securing the cable gland
5	<p>Disconnect connectors at axis 6 motor.</p>	

Continues on next page

4.3.2 Replacing the cable harness, upper end (incl. axis 6)

Continued

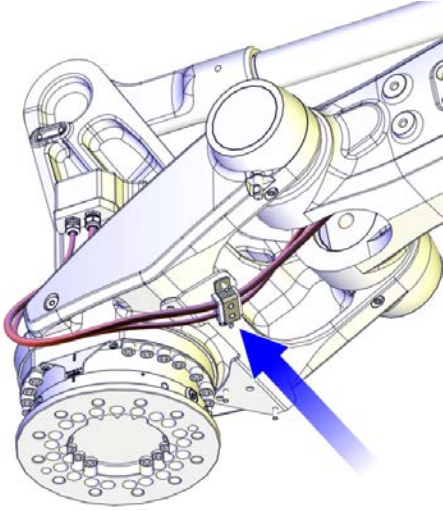
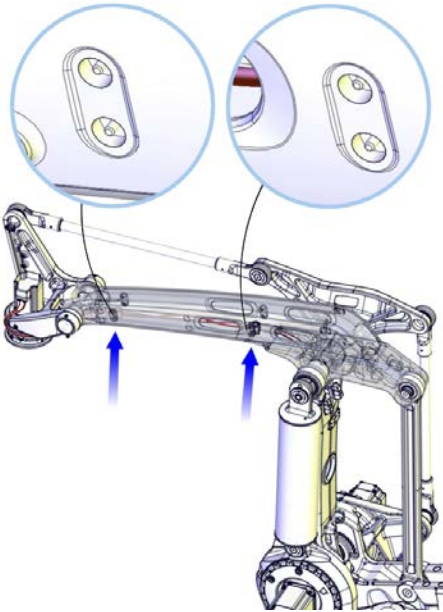
	Action	Note
6	Remove the metal clamp that holds the cable at the tilt house, by removing its nuts.	 <p>xx1000001336</p>
7	Carefully pull the cable harness out of motor axis 6.	
8	Remove the nuts (on the outside of the upper arm) that secure the cable harness metal clamps inside the upper arm (2 + 2 pcs).	 <p>xx1000001338</p>
9	Carefully pull out the cable harness from the upper and lower arm.	

Continues on next page

4 Repair

4.3.2 Replacing the cable harness, upper end (incl. axis 6)



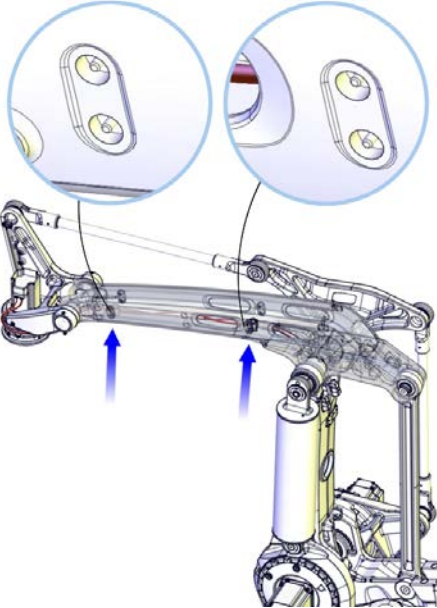
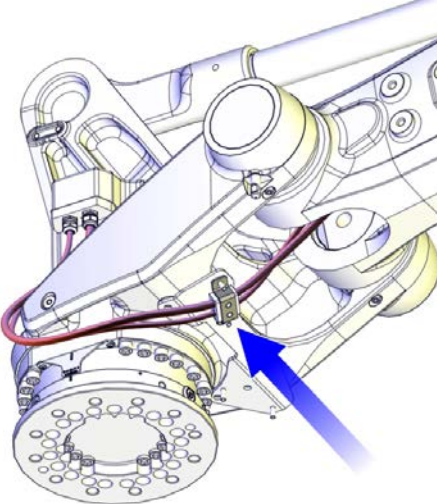

Continued

Refitting cable harness, upper end

Use this procedure to refit the cable harness, upper end.

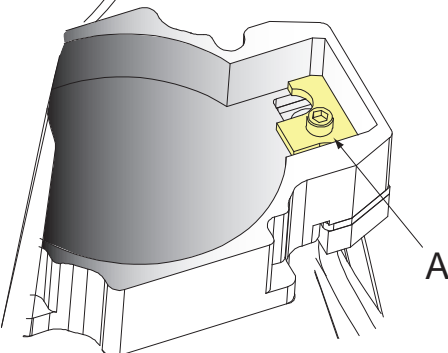
	Action	Note
1	Start by fitting the cable harness, lower end if it has been removed.	Detailed in section Replacing cable harness, lower end (axes 1-3) on page 148
2	Push the cable harness through the upper arm tube.	
3	Refit the cable harness inside the upper arm by refitting the cable clamps with the nuts (2 + 2 pcs) from the outside of the upper arm.	 <p>xx1000001338</p>
4	Refit the <i>metal clamp</i> at the tilthouse with its nuts.	 <p>xx1000001336</p>

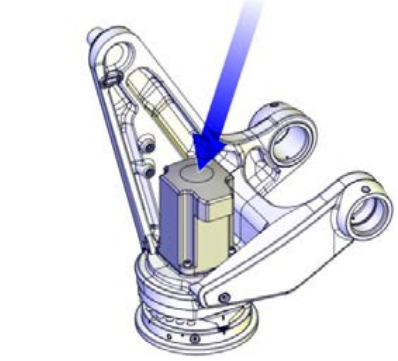
Continues on next page

	Action	Note
5	Push the axis 6 motor cables carefully through the cable gland.  Note Do not twist the cables!	
6	Reconnect all connectors in motor axis 6.	
7	Check the <i>gasket</i> . If damaged, replace it.	
8	Refit the cable gland with its <i>attachment screw</i> .	 <p>xx0600002694</p> <ul style="list-style-type: none"> • A: Screw holding the cable gland <p>Make sure the gasket is not damaged! Replace if damaged.</p>
9	Refit the <i>cover</i> , motor axis 6 with its <i>attachment screws</i> and <i>washers</i> . Make sure the cabling is placed correctly when refitting the cover and does not get jammed.  Note Make sure the cover is tightly sealed!	 <p>xx1000001106</p>
10	Make an overall inspection of the installed cable harness.	See Inspecting, cable harness on page 107 .
11	Update the revolution counter!	Detailed in section Updating revolution counters on IRC5 robots on page 308 .
12	 DANGER Make sure all safety requirements are met when performing the first test run.	

4 Repair

4.3.3 Replacing the base, including axis 1 gearbox

4.3.3 Replacing the base, including axis 1 gearbox

Introduction

The term *complete arm system* used in this procedure is defined as the complete robot excluding:

- base
- gearbox axis 1

Location of the base

The location of the base, including gearbox axis 1, is shown in the figure. It also shows the complete arm system as defined above.

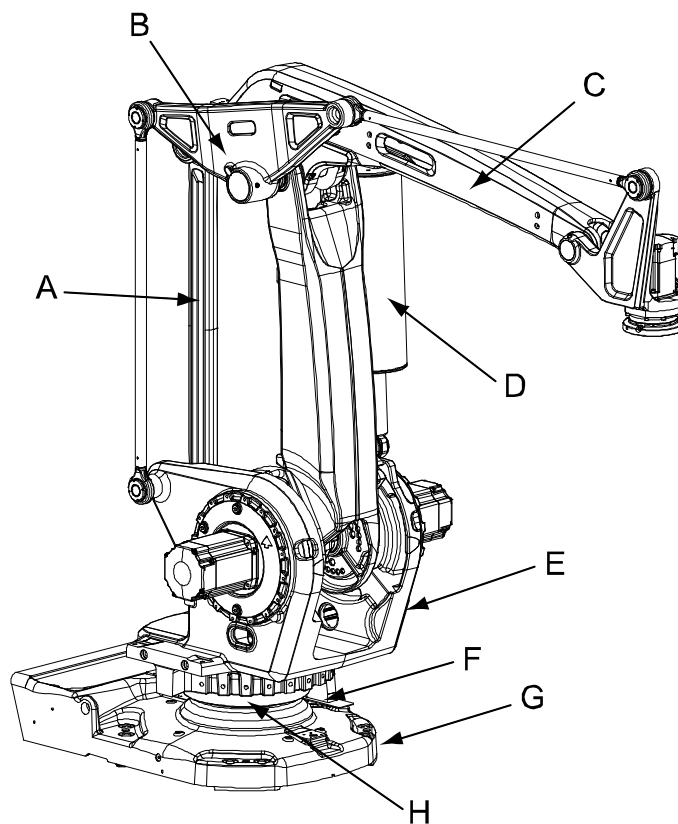

xx0600002612

A	Parallel rod
B	Linkage
C	Complete upper arm (incl. tilthouse)
D	Balancing device
E	Frame
F	Gearbox, axis 1
G	Base
H	Base attachment screws

Continues on next page

Required equipment

Equipment, etc.	Art. no.	Note
Guide pins M12 x 130	3HAC022637-001	Used to guide the complete arm system when refitting. Always use the guide pins in pairs! Guide pins that are longer than 140 mm will not be possible to remove because the lack of space.
Lifting accessory	3HAC15607-1	Includes: <ul style="list-style-type: none"> user instructions, 3HAC15971-2
Roundsling		1 pc: 1,5 m Lifting capacity 1,000 kg
Hoisting block	-	Used to adjust the length of the lifting chain.
Power supply	-	24 VDC, max. 1.5 A For releasing the brakes.
Crank	-	Used to turn the gear when mating it to the frame.
Standard toolkit	-	Content is defined in section Standard tools on page 346 .
Other tools and procedures may be required. See references to these procedures in the step-by-step instructions below.		These procedures include references to the tools required.
Circuit diagram	-	See chapter Circuit diagrams on page 353 .

Deciding calibration routine

Decide which calibration routine to be used, based on the information in the table. Depending on which routine is chosen, action might be required prior to beginning the repair work of the robot, see the table.

	Action	Note
1	Decide which calibration routine to use for calibrating the robot. <ul style="list-style-type: none"> Reference calibration. External cable packages (DressPack) and tools can stay fitted on the robot. Fine calibration. All external cable packages (DressPack) and tools must be removed from the robot. 	

Continues on next page

4 Repair



4.3.3 Replacing the base, including axis 1 gearbox

Continued

Action	Note
<p>If the robot is to be calibrated with reference calibration: Find previous reference values for the axis or create new reference values. These values are to be used after the repair procedure is completed, for calibration of the robot.</p> <p>If no previous reference values exist, and no new reference values can be created, then reference calibration is not possible.</p>	<p>Follow the instructions given in the reference calibration routine on the FlexPendant to create reference values.</p> <p>Creating new values requires possibility to move the robot.</p> <p>Read more about reference calibration for Axis Calibration in <i>Product manual - IRB 4600</i>.</p>
<p>If the robot is to be calibrated with fine calibration: Remove all external cable packages (DressPack) and tools from the robot.</p>	

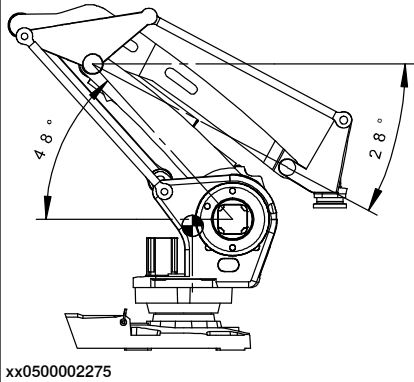

Removing the complete arm system

Use this procedure to remove the complete arm system.

Action	Note
1	Decide which calibration routine to use, and take actions accordingly prior to beginning the repair procedure.
2	<p>Move the robot to the transport position.</p>  <p>xx0500002275</p>
3	<p> DANGER</p> <p>Turn off all:</p> <ul style="list-style-type: none"> • electric power supply • hydraulic pressure supply • air pressure supply <p>to the robot, before entering the robot working area.</p>
4	Run an overhead crane to a position above the robot.

Continues on next page

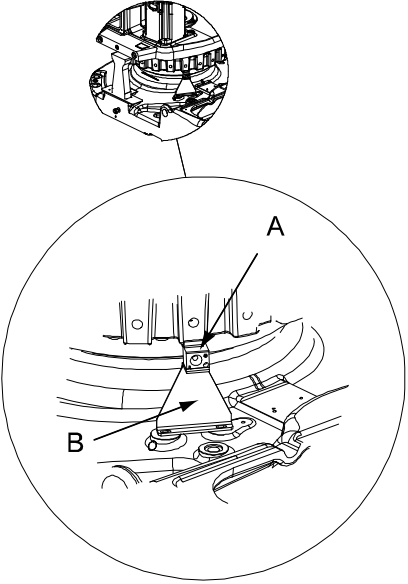
4.3.3 Replacing the base, including axis 1 gearbox
Continued





	Action	Note
5	Remove the <i>block for calibration</i> and the <i>axis 1 calibration plate</i> .	 <p>xx0600002734</p> <p>A Block for calibration B Calibration plate axis 1</p>
6	Drain the axis 1 gearbox.	See Changing oil, axis-1 gearbox on page 121 .
7	Loosen the cable connectors from the base and pull up the cabling from the base, through the hole in the center of the frame.	See Replacing cable harness, lower end (axes 1-3) on page 148 .
8	Remove the axis 1 motor.	See Replacing motor, axis 1 on page 249 .
9	 CAUTION The robot arm system weighs 245 kg. All lifting accessories used must be sized accordingly!	
10	Fit the lifting accessories and adjust it as described in the enclosed user instructions.	Make sure the lift is done completely level. This is detailed in section Lifting robot with lifting accessory (recommended lifting method) on page 58 .

Continues on next page

4 Repair

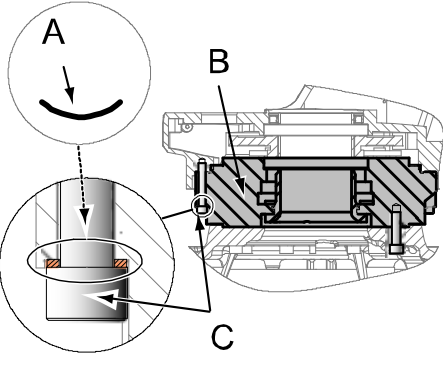
4.3.3 Replacing the base, including axis 1 gearbox

Continued

Action	Note
<p>11 Unfasten the arm system from the base by unscrewing the attachment screws.</p>	 <p>xx0600003070</p> <p>A Serrated lock washer B Axis 1 gearbox C Attachment screws M12x80</p>
<p>12 Fit two <i>guide pins</i> in the holes. This will facilitate the removal of the complete arm system and prevent damage on the gearbox.</p>	<p>Article number is specified in Required equipment on page 163.</p>
<p>13 Lift the <i>complete arm system</i> carefully and secure it in a safe area.</p> <p> Note</p> <p>Continue lifting even if the arm system turns out to be unbalanced despite earlier adjustments! The risk of damaging the interface is bigger if the load is lowered unbalanced!</p> <p> CAUTION</p> <p>Always move the robot at very low speed, making sure it does not tip!</p>	<p> Note</p> <p>Make sure all hooks and attachments stay in the correct position while lifting the arm system and that the lifting accessory does not wear against sharp edges.</p>
<p>14 If needed, continue to remove the axis 1 gearbox from the base.</p>	<p>See Replacing the axis 1 gearbox on page 274.</p>







Refitting the complete arm system

Use this procedure to refit the complete arm system.

Action	Note
<p>1  DANGER</p> <p>Turn off all:</p> <ul style="list-style-type: none"> • electric power supply • hydraulic pressure supply • air pressure supply <p>to the robot, before entering the robot working area.</p>	
<p>2 Refit the axis 1 gearbox, if it has been removed.</p>	<p>See Replacing the axis 1 gearbox on page 274.</p>

Continues on next page

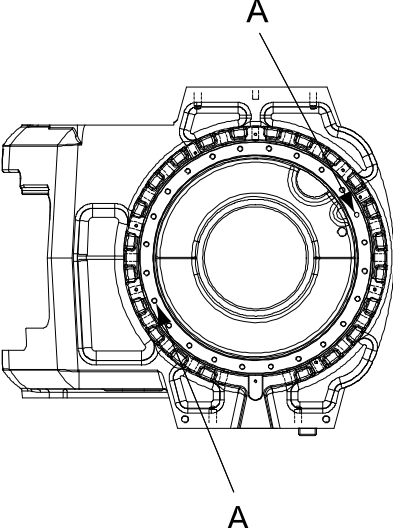
4.3.3 Replacing the base, including axis 1 gearbox
Continued



	Action	Note
3	<p> CAUTION</p> <p>The robot arm system weighs 245 kg. All lifting accessories used must be sized accordingly!</p>	
4	<p>Fit the <i>lifting accessories</i> and adjust it as described in the enclosed user instructions. Also fit a <i>hoisting block</i> to the front chain, used to adjust the balance of the arm system in order to lift it completely level!</p>	<p>Article number is specified in Required equipment on page 163. Make sure the lift is done completely level! How to adjust the lift is described in the enclosed instruction to the lifting accessory! Follow the instructions before lifting! This is detailed in section Lifting robot with lifting accessory (recommended lifting method) on page 58.</p>
5	<p>Lift the complete arm system and move it at very low speed to the mounting site, making sure it does not tip!</p> <p> Note</p> <p>The refitting must be made completely level! Make sure the roundslings are adjusted prior to refitting the arm system.</p>	<p> Note</p> <p>Make sure all hooks and attachments stay in the correct position while lifting the arm system and that the lifting accessory does not wear against sharp edges.</p>
6	<p>Fit two <i>guide pins</i> in opposite holes in the frame.</p> <p> Tip</p> <p>In order to make refitting easier it is recommended to use two guide pins of different lengths. Notice that longer guide pins than 140 mm will not be possible to remove after refitting because of lack of space.</p>	 <p>xx0600002632</p> <p>The figure above shows the frame, view from below.</p> <ul style="list-style-type: none"> A: Attachment holes for the guide pins, M12 <p>Dimension is specified in Required equipment on page 163.</p> <p> Note</p> <p>Always use guide pins in pairs.</p>

Continues on next page

4 Repair

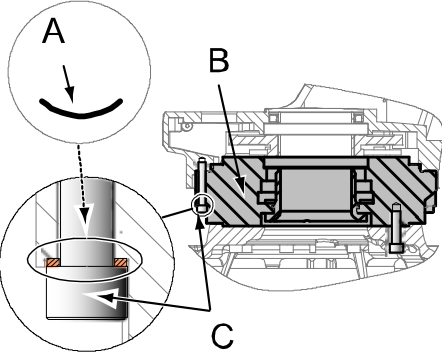

4.3.3 Replacing the base, including axis 1 gearbox

Continued

	Action	Note
7	Look through the empty mounting hole of the axis 1 motor to assist in aligning the assembly during refitting of the complete arm system.	
8	<p>Lower the complete arm system with guidance from the guide pins previously fitted to the axis 1 gearbox.</p> <p> Note</p> <p>The refitting must be made completely level! Make sure the roundslings are adjusted prior to refitting the arm system.</p>	<p> CAUTION</p> <p>This is a complex task to be performed with utmost care in order to avoid injury or damage!</p> <p>Use a crank to turn the gearbox in order to find the right position for the holes.</p>
9	<p>Place the <i>serrated lock washers</i> on the attachment screws.</p> <p> Note</p> <p>Check that the <i>serrated lock washers</i> are turned the correct way. See figure!</p>	<p>Reused screws can be used providing they are lubricated as described in Screw joints on page 342.</p>  <p>xx0600003070</p> <p>Parts:</p> <ul style="list-style-type: none"> A Serrated lock washer (24 pcs) B Axis 1 gearbox C Attachment screws M12x110 quality 12.9 gleitmo (24 pcs)
10	Fit 22 of the 24 attachment screws before the arm system is completely lowered. This is done in order to be able to attach all screws into the threads correctly.	
11	Replace the guide pins with the remaining attachment screws and secure the complete arm system to the base with its attachment screws and washers.	
12	Lower the arm system completely.	
13	Secure the complete arm system with its attachment screws.	Tightening torque: <ul style="list-style-type: none"> • 115 Nm.
14	Refit the cable harness in the base and the frame.	See Replacing cable harness, lower end (axes 1-3) on page 148 .
15	Refit the axis 1 motor.	See Replacing motor, axis 1 on page 249 .

Continues on next page

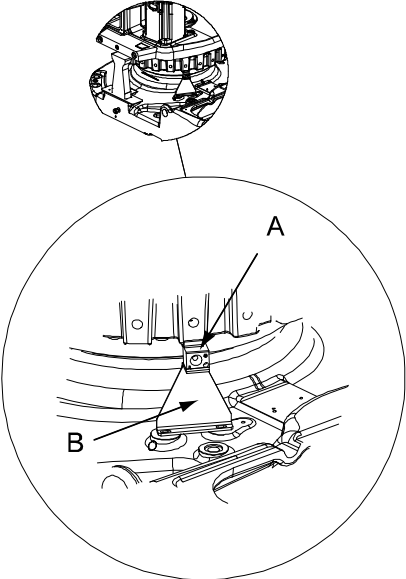
4.3.3 Replacing the base, including axis 1 gearbox
Continued

	Action	Note
16	Refit the <i>block for calibration</i> and the <i>axis 1 calibration plate</i> .	 <p>xx0600002734</p> <p>A Block for calibration B Calibration plate axis 1</p>
17	Perform a leak-down test of the axis 1 gearbox.	See Performing a leak-down test on page 140 .
18	Refill the axis 1 gearbox with lubricating oil.	See Changing oil, axis-1 gearbox on page 121 .
19	Recalibrate the robot.	Axis Calibration is described in Calibrating with Axis Calibration method on page 314 . General calibration information is included in section Calibration on page 303 .
20	 <p>DANGER</p> <p>Make sure all safety requirements are met when performing the first test run.</p>	

4 Repair

4.4.1 Replacing the turning disk

4.4 Upper and lower arm

4.4.1 Replacing the turning disk

Location of turning disk

The turning disk is located in the front of the wrist housing as shown in the figure below.

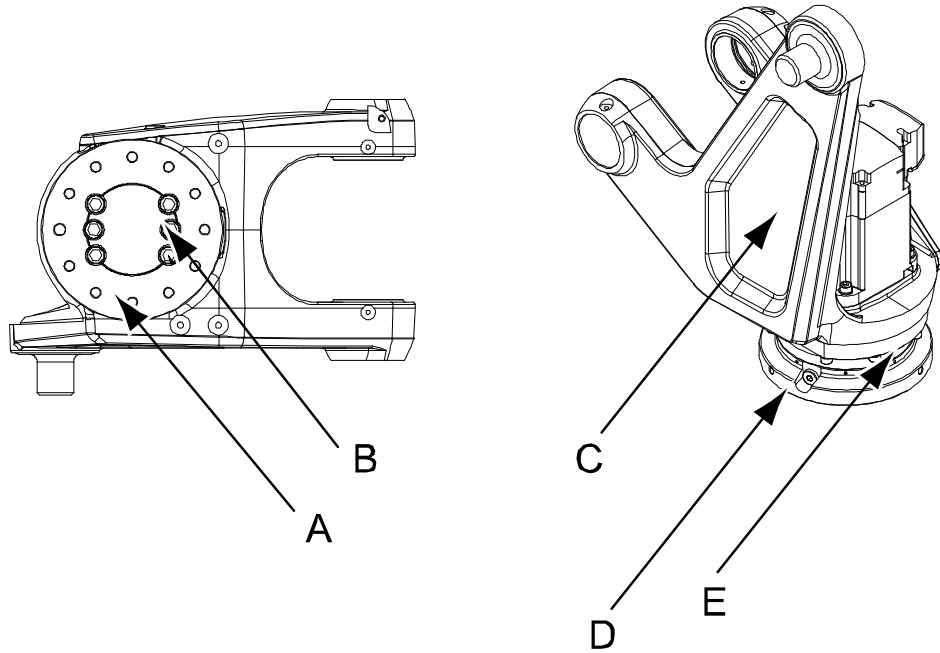

xx0600002627

A	Turning disk
B	Attachment screws (6 pcs) turning disk
C	Tilthouse unit
D	Gearbox, axis 6
E	Attachment screws, axis 6

Required equipment

Equipment, etc.	Art. no.	Note
Turning disk	For spare part no. see: Spare part lists on page 351 .	O-rings are not included!
O-ring Wrist, type 1	3HAB3772-65 (1pc) 21520431-20 (6 pcs)	For robot v. IRB 660 180/3.15, 250/3.15 Must be replaced when replacing the turning disk!
Grease	3HAC042536-001	Shell Gadus S2 Used to lubricate the o-rings.
Flange sealant	3HAC034903-001	Loctite 574

Continues on next page

Equipment, etc.	Art. no.	Note
Standard toolkit	-	Content is defined in section Standard tools on page 346 .
Other tools and procedures may be required. See references to these procedures in the step-by-step instructions below.		These procedures include references to the tools required.

Removing, turning disk

Use this procedure to remove the turning disk.

	Action	Note
1	Run the robot to a position where the tilthouse is best positioned for the turning disk to be replaced.	
2	 DANGER Turn off all: <ul style="list-style-type: none"> • electric power supply • hydraulic pressure supply • air pressure supply to the robot, before entering the robot working area.	
3	Remove any equipment fitted to the turning disk.	
4	Drain the axis 6 gearbox.	See section <ul style="list-style-type: none"> • Changing oil, gearbox axis 6 on page 128
5	Remove the <i>attachment screws</i> that secure the turning disk.	Shown in the figure Location of turning disk on page 170 .
6	Remove the <i>turning disk</i> .	
7	<i>Foundry Plus:</i> Remove old flange sealant residues and other contamination from the contact surfaces.	

Continues on next page

4 Repair

4.4.1 Replacing the turning disk

Continued

Refitting, turning disk

Use this procedure to refit the turning disk.

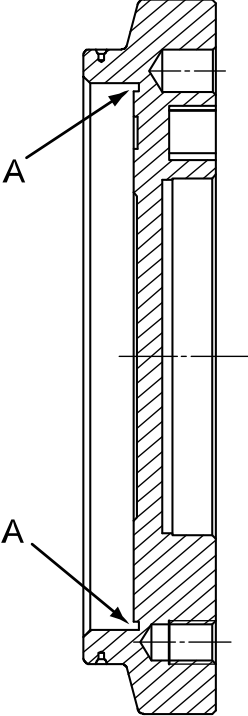
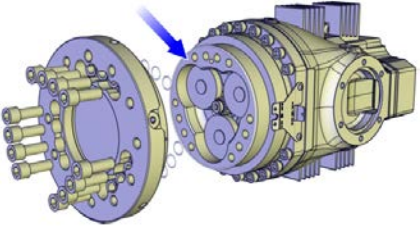
	Action	Note
1	Lubricate the <i>o-ring</i> of the turning disk with <i>grease</i> and fit it to the turning disk. Also fit the six <i>o-rings</i> , when refitting the attachment screws.	<p>Art. no. is specified in Required equipment on page 170.</p>  <p>xx0200000218</p> <ul style="list-style-type: none"> A: Sealing surface, o-ring
2	Foundry Plus: Apply Loctite 574 flange sealant on the contact surface.	 <p>xx1400000995</p>
3	Secure the turning disk with its <i>attachment screws</i> .	<p>6 pcs M14 x 25, 12.9 quality. Tightening torque: 175 Nm Reused screws may be used, providing they are lubricated as detailed in section Screw joints on page 342 before fitting.</p>
4	Perform a <i>leak-down test</i> of the gearbox axis 6.	Detailed in the section Performing a leak-down test on page 140 .
5	Refill the axis 6 gearbox with oil.	<p>See section</p> <ul style="list-style-type: none"> Changing oil, gearbox axis 6 on page 128
6	Refit any equipment removed during disassembly to the turning disk.	

Continues on next page

	Action	Note
7	 DANGER Make sure all safety requirements are met when performing the first test run.	

4 Repair

4.4.2 Replacement of tilthouse unit

4.4.2 Replacement of tilthouse unit

Location of tilt house

The tilthouse unit is located as shown in the figure below.

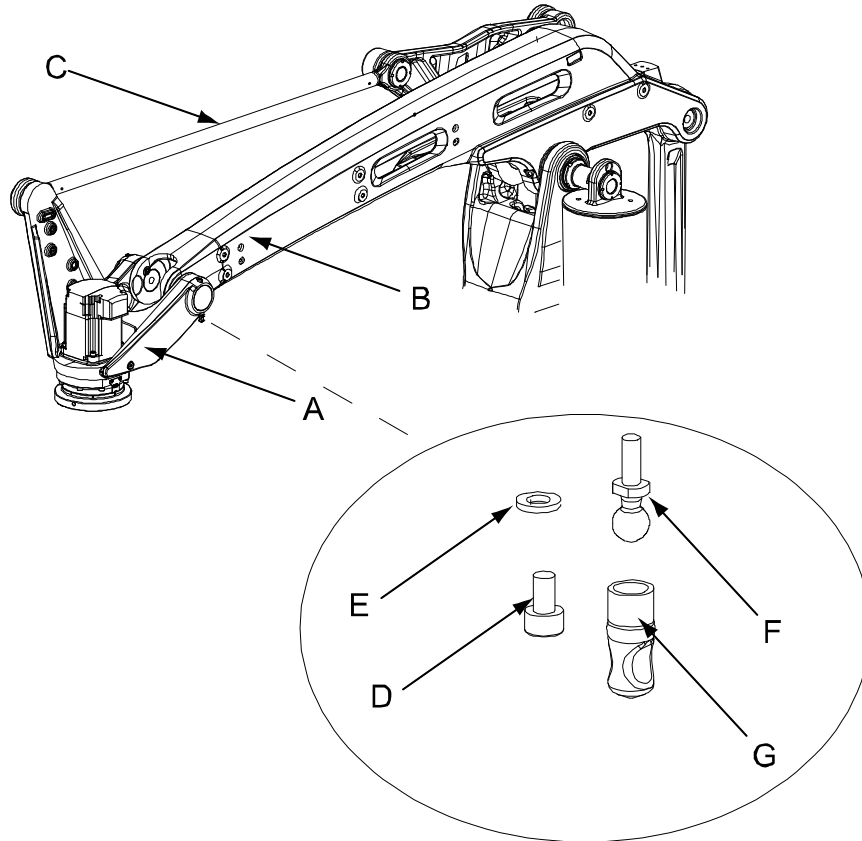

xx0600002616

A	Tilthouse unit
B	Upper arm
C	Upper rod
D	Screw M6x10
E	Washer 6.4x12x1.6
F	Ballplug
G	Protection cap

Continues on next page

Location of axes 2 and 3 sides of the robot

The figure below shows the location of the axes 2 and 3 sides of the robot. See markings on the lower arm (axis 2) and the parallel arm (axis 3).

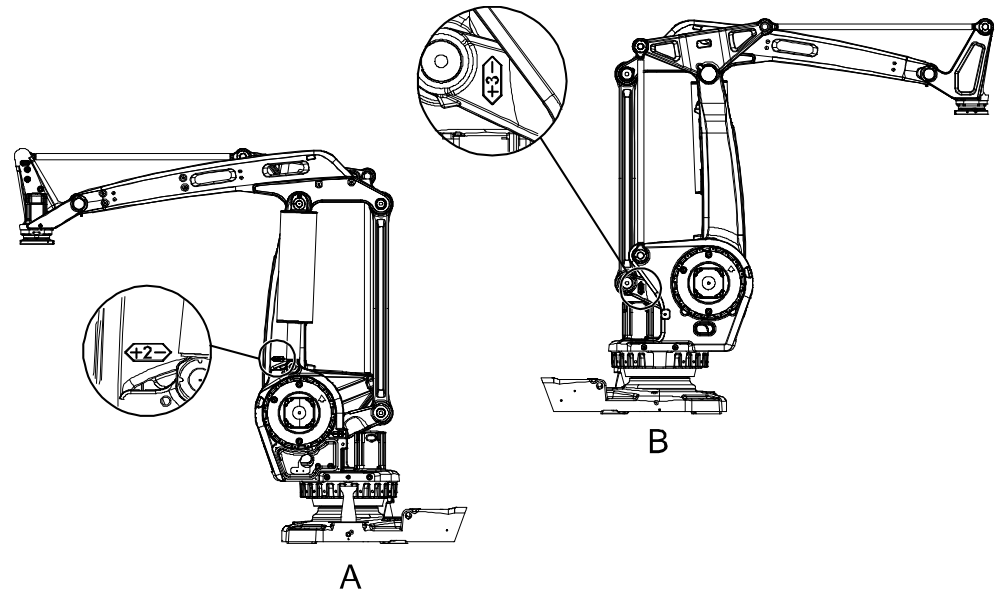

xx0600002743

A	Axis 2 side of the robot
B	Axis 3 side of the robot

Cut away view of the assembly of the tilthouse unit

The figure below shows a cut away view of how the tilthouse unit is fitted to the upper arm. The letters in the figure are being referred to in the step by step procedures below.

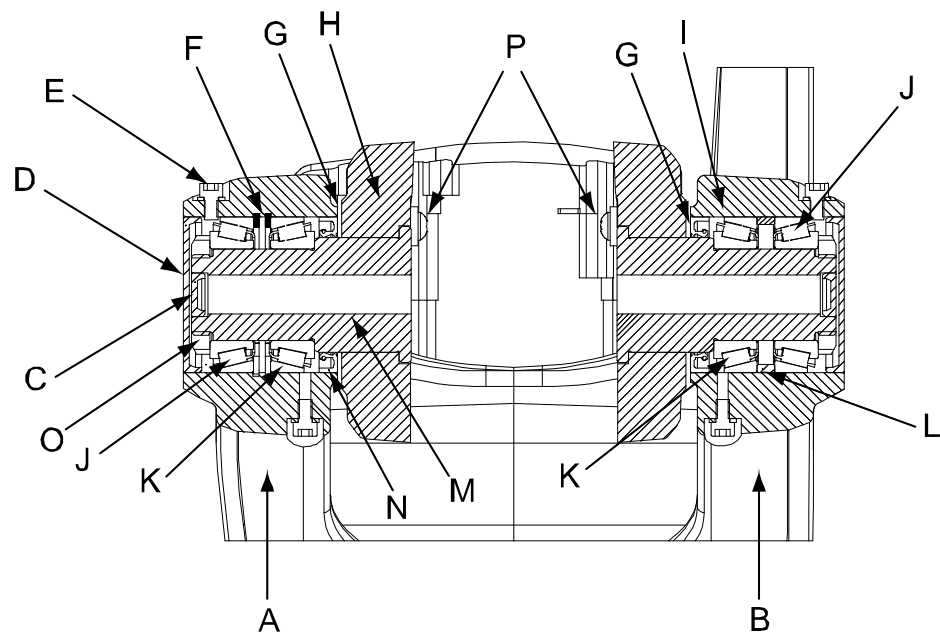

xx0600002742

Continues on next page

4 Repair

4.4.2 Replacement of tilthouse unit

Continued

A	Axis 2 side
B	Axis 3 side
C	VK cover, VK 19 x 6, 2 pcs
D	VK cover, VK 68 x 8, 2 pcs
E	Screw M6 x 10 Steel 8.8-A2F + Washers, 4 + 4 pcs (for filling bearing grease)
F	Retaining ring fore bores, 2 pcs
G	Rust protection, Dinitrol 490
H	Upper arm
I	Tilthouse
J	Bearing, 2 pcs (on the outside of the tilthouse)
K	Bearing, 2 pcs (on the inside of the tilthouse)
L	Ring
M	Shaft, 2 pcs
N	Radial seal with dustlip, 2 pcs
O	Lock nut, KM7 2 pcs
P	Screw M6x16 + washer (for locking the shafts), 2 + 2 pcs

Required equipment

Equipment, etc.	Art.no.	Note
Press tool, premounting bearing	3HAC023075-001	
Press tool, mounting axis 6	3HAC077982-001	Hydraulic pressing accessory. User instructions are enclosed with the tool.
KM7 socket	6369901-438	
Shims		Width = 3 mm
Grease	3HAC042536-001	Shell Gadus S2
Rust protection		Dinitrol 490
Locking liquid		Loctite 243
Standard toolkit	-	Content is defined in section Standard tools on page 346 .
Other tools and procedures may be required. See references to these procedures in the step-by-step instructions below.		These procedures include references to the tools required.
Circuit diagram	-	See chapter Circuit diagrams on page 353 .

Continues on next page

Press tool premounting bearing

The press tool for premounting the bearing race, bearing complete, radial seal with dustlip and ring in the tilthouse, is assembled with the parts shown in the figure below.

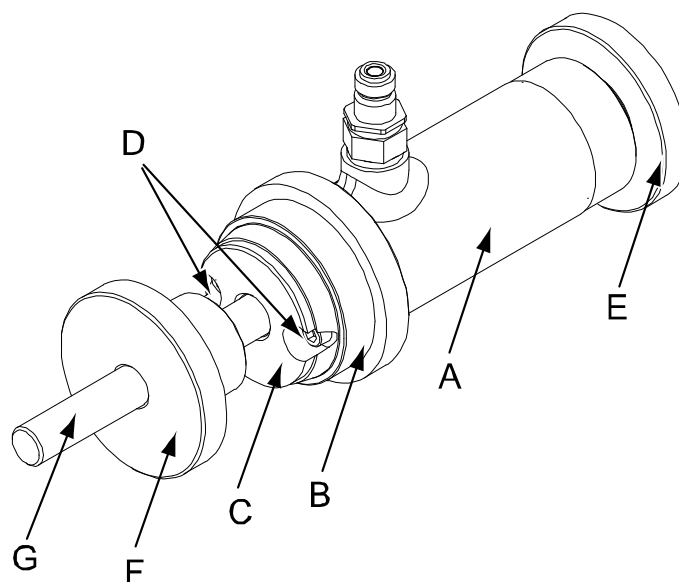

xx0600002750

▣

Note! The parts cannot be ordered separately, but are included when ordering the complete tool. The article numbers are given only for identification.

A	Hydraulic cylinder, 3HAC 11731-1
B	Mounting washer, 3HAC 023075-004
C	Bushing, 3HAC 023075-006
D	Screw M6x25, 2 pcs (MC6S)
E	Threaded washer, 3HAC 5507-1
F	Press washer, 3HAC 023075-002
G	Threaded bar, M16 L = 300 mm

Deciding calibration routine

Decide which calibration routine to be used, based on the information in the table. Depending on which routine is chosen, action might be required prior to beginning the repair work of the robot, see the table.

	Action	Note
1	Decide which calibration routine to use for calibrating the robot. <ul style="list-style-type: none"> Reference calibration. External cable packages (DressPack) and tools can stay fitted on the robot. Fine calibration. All external cable packages (DressPack) and tools must be removed from the robot. 	

Continues on next page

4 Repair

4.4.2 Replacement of tilthouse unit



Continued

Action	Note
<p>If the robot is to be calibrated with reference calibration: Find previous reference values for the axis or create new reference values. These values are to be used after the repair procedure is completed, for calibration of the robot.</p> <p>If no previous reference values exist, and no new reference values can be created, then reference calibration is not possible.</p>	<p>Follow the instructions given in the reference calibration routine on the FlexPendant to create reference values.</p> <p>Creating new values requires possibility to move the robot.</p> <p>Read more about reference calibration for Axis Calibration in <i>Product manual - IRB 4600</i>.</p>
<p>If the robot is to be calibrated with fine calibration: Remove all external cable packages (DressPack) and tools from the robot.</p>	



Removal, tilthouse

This procedure describes how to remove the tilthouse unit.

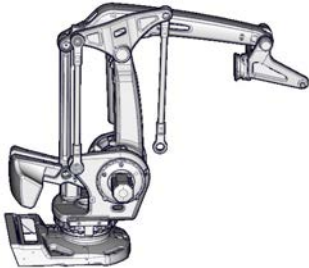
The item letters within parentheses refer to the figure [Cut away view of the assembly of the tilthouse unit on page 175](#).

	Action	Note
1	Decide which calibration routine to use, and take actions accordingly prior to beginning the repair procedure.	
2	Move the robot to a position where the tilthouse rests on a workbench, pallets or similar.	
3	<p> DANGER</p> <p>Turn off all:</p> <ul style="list-style-type: none"> • electric power supply • hydraulic pressure supply • air pressure supply <p>to the robot, before entering the robot working area.</p>	
4	<p>Secure the <i>tilthouse</i> with a roundsling in an overhead crane.</p> <p>This is done in order to prevent the tilthouse from falling down when the upper link is removed.</p> <p> DANGER</p> <p>If not secured the tilthouse will fall down when the upper link is removed. See figure!</p>	 <p>xx1000001067</p>

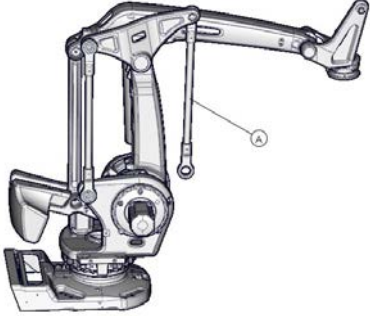
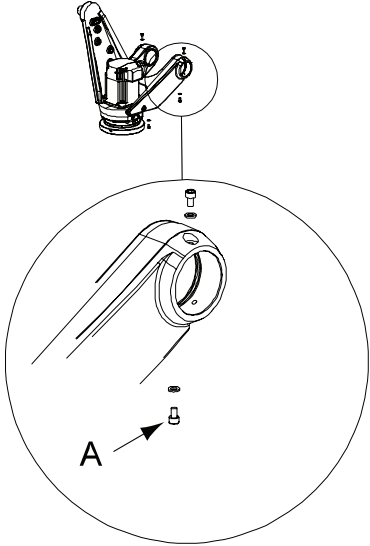
Continues on next page

	Action	Note
5	<p>Disassemble the <i>upper link</i> from the tilt house unit.</p> <p> Note</p> <p>It is not needed to remove the upper link from the link.</p>	<p>Detailed in section Replacement of linkage - upper rod on page 198</p>  <p>xx1000001065</p> <p>Part: Upper link</p>
6	<p>Disconnect <i>motor cables</i> from motor axis 6. Place the motor cables in a way that it will not be damaged.</p>	<p>Detailed in section Replacing the cable harness, upper end (incl. axis 6) on page 156</p>
7	<p>Remove one of the <i>M6 screws</i> and <i>washer</i> at the cover for filling grease.</p>	 <p>xx0600002735</p> <ul style="list-style-type: none"> • A: Screw M6, grease filling hole
8	<p>Be careful not to damage the ball plug!</p> <p> Note</p> <p>Do not remove the ball plug!</p>	<p>Shown in the figure Location of tilt house on page 174.</p>
9	<p>Remove one shaft at a time by following the steps below.</p>	

Continues on next page



4 Repair

4.4.2 Replacement of tilthouse unit

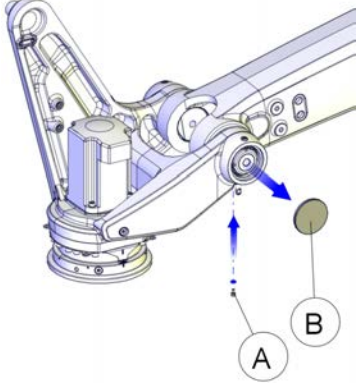
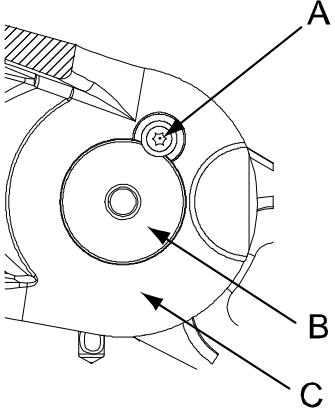
Continued

	Action	Note
10	<p>Use compressed air in the M6 hole for filling grease, in order to remove the VK cover.</p> <p> CAUTION</p> <p>Only a very low air pressure is needed!</p>	<p>Put a hand with some paper over the VK cover in order to catch it.</p>  <p>xx1000001072</p> <p>Parts:</p> <ul style="list-style-type: none">M6 screw in hole for filling greaseVK cover
11	Remove the screw that locks the shaft.	 <p>xx0600002703</p> <ul style="list-style-type: none">A: Screw M6x16B: ShaftC: Upper arm

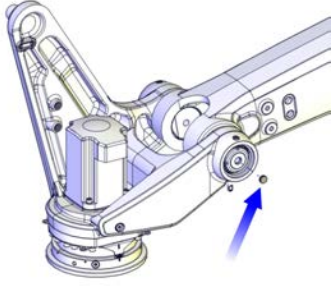
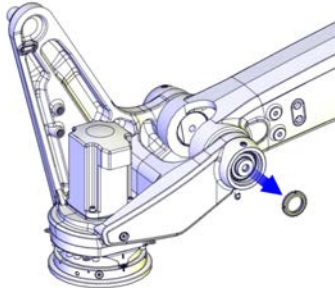
Continues on next page

	Action	Note
12	Remove the <i>small VK cover</i> from the inside with the help of a punch.	 <p>xx1000001073</p>
13	Remove the <i>lock nut</i> .	 <p>xx1000001074</p>
14	<p>Apply the press tool, mounting axis 6 in the following way:</p> <ul style="list-style-type: none"> • Push the threaded bar M16 through the holes in the shafts. • Apply the washer and the nut on the right side of the right shaft. • Put the distance ring on the bar on the left side of the shaft • Apply the hydraulic pump on the bar • Secure the hydraulic pump with a nut. <p>Remove the <i>shaft</i> with the <i>press tool</i>, mounting axis 6.</p> <p> Note</p> <p>A longer threaded bar M16 is needed when removing the shaft than the one specified when fitting.</p>	<p>Art.no. is specified in Required equipment on page 176.</p>

Continues on next page

4 Repair

4.4.2 Replacement of tilthouse unit

Continued

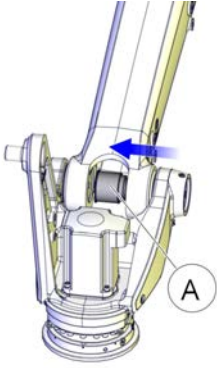
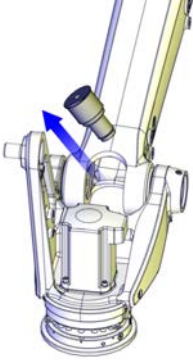
	Action	Note
15	Press out the <i>shaft</i> .	 <p data-bbox="991 801 1102 824">xx1000001075</p> <p data-bbox="1023 840 1129 869">A Shaft</p>
16	Remove the <i>press tool, mounting axis 6 and the shaft</i> .	 <p data-bbox="991 1368 1102 1391">xx1000001076</p>
17	Check that the tilthouse is secured in a overhead crane or similar before proceeding with the next shaft.	
18	Remove the other shaft in the same way.	Follow steps above.

Continues on next page

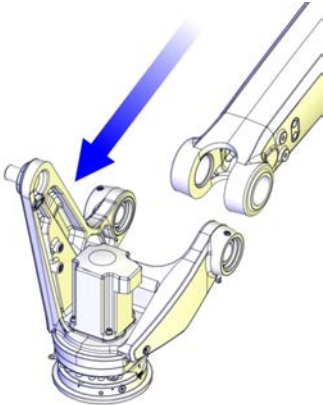
	Action	Note
19	Lift the tilthouse to a safe place.	Check that bearings are kept clean, if being refitted.  <small>xx1000001077</small>
20	Force away the sealing ring (N) with a screwdriver or similar.	The sealing must be replaced with a new one when refitting.
21	If needed change the bearings.	

Premounting tilthouse bearings and other parts, axis 2 side

The procedure below details how to fit the bearings and other parts in the tilthouse on the axis 2 side, before fitting the tilthouse to the upper arm.

This work is best done on a workbench or similar.

	Action	Note
1	Lift the tilthouse to a workbench (or similar) with a roundsling in an overhead crane.	
2	Apply some <i>grease</i> in the hole for the <i>bearings</i> (J) and (K).	Art.no. is specified in Required equipment on page 176 . Shown in the figure Cut away view of the assembly of the tilthouse unit on page 175 .
3	Fit two <i>retaining rings for bores</i> (F).	Shown in the figure Cut away view of the assembly of the tilthouse unit on page 175 .
4	Fit the outer race of the <i>bearing</i> (J) facing the outside of the tilthouse. Use a plastic hammer or similar.	Shown in the figure Cut away view of the assembly of the tilthouse unit on page 175 .
5	Thread the <i>radial seal with dustlip</i> (N) and the <i>inner bearing complete</i> (K) on the <i>presswasher</i> (F) of the <i>pressing tool, premounting bearings</i> .	Shown in the figure Cut away view of the assembly of the tilthouse unit on page 175 . Shown in the figure Press tool premounting bearing on page 177 . Art.no. is specified in Required equipment on page 176 .

Continues on next page

4 Repair

4.4.2 Replacement of tilthouse unit

Continued

	Action	Note
6	Thread the race of the outer <i>bearing</i> (J) on the <i>bushing</i> (C) of the <i>pressing tool, premounting bearings</i> .	Shown in the figure Cut away view of the assembly of the tilthouse unit on page 175 . Shown in the figure Press tool pre-mounting bearing on page 177 . Art.no. is specified in Required equipment on page 176 .
7	Fit the pressing tool and press the parts together.	

Premounting tilthouse bearings and other parts, axis 3 side

The procedure below details how to fit the bearings and other parts in the tilthouse on the axis 3 side, before fitting the tilthouse to the upper arm.

This work is best done on a workbench or similar.

	Action	Note
1	Apply some <i>grease</i> in the hole for the <i>bearings</i> (J) and (K).	Art.no. is specified in Required equipment on page 176 . Shown in the figure Cut away view of the assembly of the tilthouse unit on page 175 .
2	Fit the outer race of the <i>bearing</i> (J) facing the outside of the tilthouse. Use a plastic hammer or similar.	Shown in the figure Cut away view of the assembly of the tilthouse unit on page 175 .
3	Thread the <i>radial seal with dustlip</i> (N), the <i>inner bearing complete</i> (K) and the <i>ring</i> (L) on the <i>press washer</i> (F) of the <i>pressing tool, premounting bearings</i> .	Shown in the figure Cut away view of the assembly of the tilthouse unit on page 175 . Shown in the figure Press tool pre-mounting bearing on page 177 . Art.no. specified in Required equipment on page 176 .
4	Thread the race of the outer <i>bearing</i> (J) on the <i>bushing</i> (C) of the <i>pressing tool, premounting bearings</i> .	Shown in the figure Cut away view of the assembly of the tilthouse unit on page 175 . Shown in the figure Press tool pre-mounting bearing on page 177 . Art.no. is specified in Required equipment on page 176 .
5	Fit the pressing tool and press the parts together.	



Refitting, tilt house

The procedure below details how to refit the tilthouse unit.

Before starting this procedure, prepare the tilthouse as detailed in the procedures [Premounting tilthouse bearings and other parts, axis 2 side on page 183](#) and [Premounting tilthouse bearings and other parts, axis 3 side on page 184](#).

	Action	Note
1	Secure the tilthouse with a roundsling in an overhead crane and lift it to its mounting position on the upper arm.	

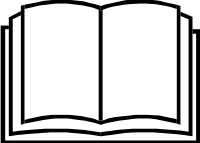
Continues on next page

	Action	Note
2	Apply <i>Dinitrol 490</i> (G) on the surfaces where the tilthouse faces the upper arm for rust protection.	Shown in the figure Cut away view of the assembly of the tilthouse unit on page 175 .
3	Apply some <i>grease</i> in the holes for the <i>shafts</i> (M) in the upper arm.	Art. no. is specified in Required equipment on page 176 . Shown in the figure Cut away view of the assembly of the tilthouse unit on page 175 .
4	<i>Note!</i> Fit the axis 2 side first.	Shown in the figure Location of axes 2 and 3 sides of the robot on page 175 .
5	Push the axis 2 <i>shaft</i> (M) into its hole, from the inside.	Shown in the figure Cut away view of the assembly of the tilthouse unit on page 175 .
6	<p>Thread the race of the <i>bearing</i> (J) facing the outside of the tilthouse, on the <i>press housing</i> (C) of the <i>press tool</i>, mounting axis 6 and fit it on the <i>shaft</i> (M).</p>  <p>xx0900000813</p> <p>Go to the user instructions enclosed with the press tool.</p> <p> DANGER</p> <p>Handling the tool incorrectly will cause serious injury. Read and follow enclosed user instructions for the tool.</p>	<p>Shown in the figure Cut away view of the assembly of the tilthouse unit on page 175.</p> <p>Art. no. is specified in Required equipment on page 176.</p>
7	Apply locking liquid on the lock nut, KM7 axis 2 side and fit it with the flat surface facing inside.	Loctite 243. Tightening torque: 90 Nm
8	Apply locking liquid on the lock nut, KM7 axis 3 side and fit it with the flat surface facing inside.	Loctite 243. Tightening torque: 90 Nm

Continues on next page

4 Repair

4.4.2 Replacement of tilthouse unit

Continued

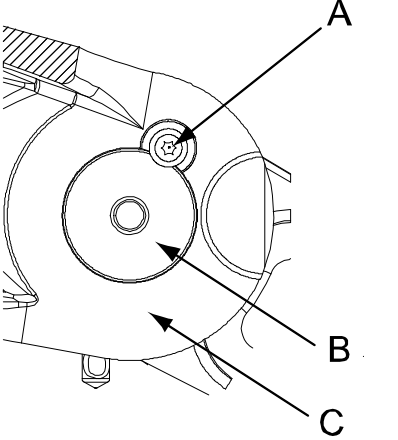
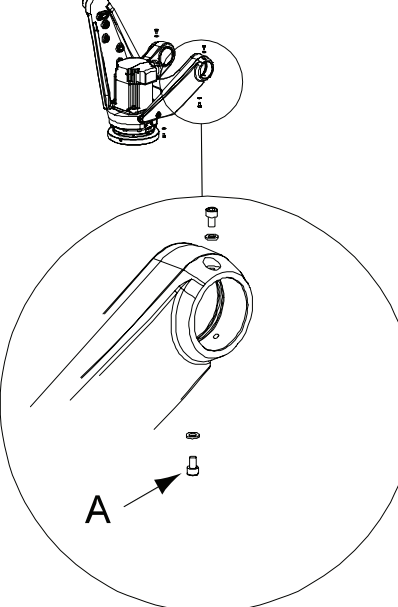
	Action	Note
9	Apply locking liquid in the holes for the screws locking the shafts and fit screws and washers on both sides, locking the shafts.	 <p>xx0600002703</p> <ul style="list-style-type: none"> • A: Screw M6x16 • B: Shaft • C: Upper arm
10	Fit the inner VK cover (C) on both axes.	Shown in the figure <i>Cut away view of the assembly of the tilthouse unit on page 175.</i>
11	Fit the outer VK cover (D) on both axes.	Shown in the figure <i>Cut away view of the assembly of the tilthouse unit on page 175.</i>
12	Fill bearings with grease.	Specified in <i>Required equipment on page 176.</i>
13	Refit the motor cable, axis 6.	Detailed in section <i>Replacing the cable harness, upper end (incl. axis 6) on page 156</i>
14	Refit the M6 screw and washer at the cover for filling grease.	 <p>xx0600002735</p> <ul style="list-style-type: none"> • A: Screw M6, grease filling hole

Continues on next page

	Action	Note
15	Refit the upper rod.	Detailed in section Replacement of linkage - upper rod on page 198
16	Recalibrate the robot.	Axis Calibration is described in Calibrating with Axis Calibration method on page 314 . General calibration information is included in section Calibration on page 303 .
17	 DANGER Make sure all safety requirements are met when performing the first test run.	

4 Repair

4.4.3 Replacement of upper arm

4.4.3 Replacement of upper arm

Location of upper arm

The upper arm is located as shown below.

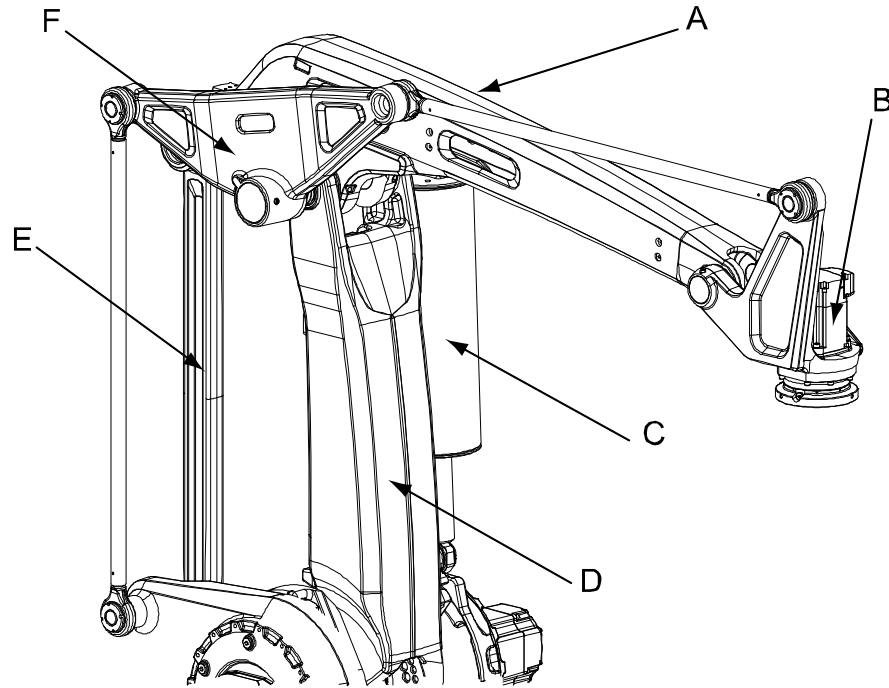

xx0600002609

A	Upper arm
B	Motor axis 6
C	Balancing device
D	Lower arm
E	Parallel rod
F	Linkage

Continues on next page

View of the assembly of the upper arm components

Shown below is a cut away view of how the upper arm is fitted to the lower arm (seen from above). The letters are being referred to in the following step by step procedures.

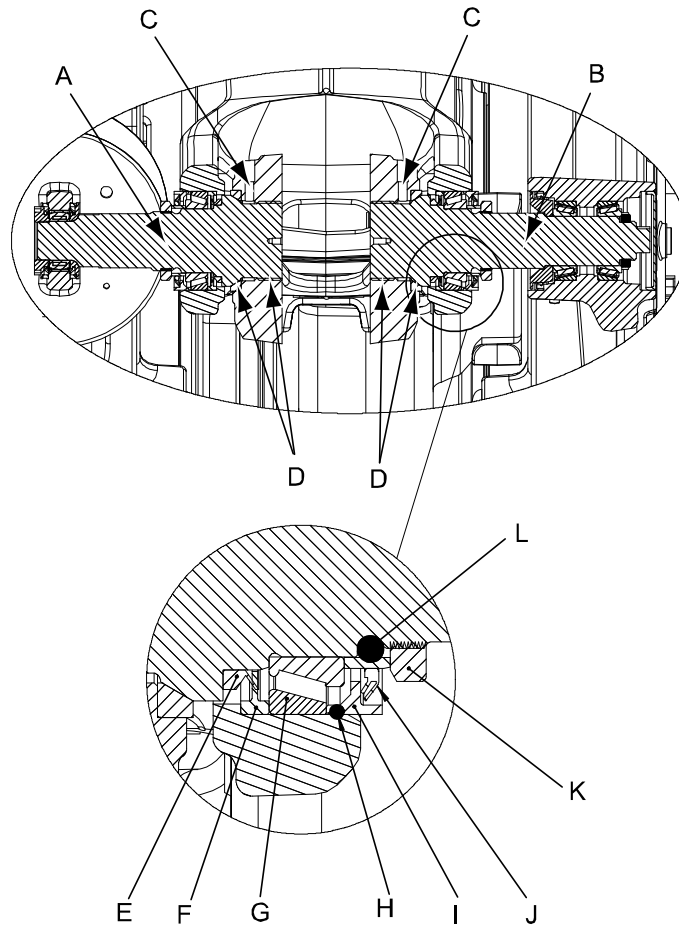

xx0600002692

A	Shaft, axis 2
B	Shaft, axis 3
C	Set screw, cup point (M10 x 20)
D	Lubricant paste (Molycote 1000)
E	Sealing ring (V-ring)
F	Sealing ring
G	Taper roller bearing
H	O-ring
I	Sealing ring
J	Sealing assembly
K	Lock nut (KM12)
L	O-ring (Di = 54.2 mm, t = 5.7 mm)

Continues on next page

4 Repair

4.4.3 Replacement of upper arm

Continued

Required equipment

Equipment, etc.	Art.no.	Note
Upper arm, axis 4	For spare part part number, see Spare part lists on page 351 .	
Support ring	For spare part part number, see Spare part lists on page 351 .	2 pcs Install on a new upper arm.
Adapter	3HAC071308-001	Used on the axis-3 shaft.
Grease filling tool	-	
Rust preventive	3HAC034903-001	Mercasol 3110 Waxcoat
Press tool, support ring	3HAC072616-001	Used to press in the support rings in the upper arm housing.
Pressing tool, upper arm	3HAC023084-001	Used on the bearings.
KM12 socket	3HAC023739-001	
Standard toolkit	-	Content is defined in section Standard tools on page 346 .
Other tools and procedures may be required. See references to these procedures in the step-by-step instructions below.		These procedures include references to the tools required.
Circuit diagram	-	See chapter Circuit diagrams on page 353 .

Deciding calibration routine

Decide which calibration routine to be used, based on the information in the table. Depending on which routine is chosen, action might be required prior to beginning the repair work of the robot, see the table.



	Action	Note
1	<p>Decide which calibration routine to use for calibrating the robot.</p> <ul style="list-style-type: none"> Reference calibration. External cable packages (DressPack) and tools can stay fitted on the robot. Fine calibration. All external cable packages (DressPack) and tools must be removed from the robot. 	
	<p>If the robot is to be calibrated with reference calibration:</p> <p>Find previous reference values for the axis or create new reference values. These values are to be used after the repair procedure is completed, for calibration of the robot.</p> <p>If no previous reference values exist, and no new reference values can be created, then reference calibration is not possible.</p>	<p>Follow the instructions given in the reference calibration routine on the FlexPendant to create reference values.</p> <p>Creating new values requires possibility to move the robot.</p> <p>Read more about reference calibration for Axis Calibration in <i>Product manual - IRB 4600</i>.</p>

Continues on next page

Action	Note
<p>If the robot is to be calibrated with fine calibration:</p> <p>Remove all external cable packages (DressPack) and tools from the robot.</p>	

Removal, upper arm

The procedure below details how to remove the upper arm.

	Action	Note
1	Decide which calibration routine to use, and take actions accordingly prior to beginning the repair procedure.	
2	Remove all equipment fitted to the turning disk.	
3	Move the upper arm to a horizontal position.	
4	 DANGER Turn off all: <ul style="list-style-type: none"> • electric power supply • hydraulic pressure supply • air pressure supply to the robot, before entering the robot working area.	
5	Secure the <i>upper arm</i> with roundslings in an overhead crane.	
6	Remove the <i>cable harness</i> in the upper arm.	Detailed in section
7	 CAUTION The complete upper arm with weights 170 kg (without any additional equipment fitted). Use a suitable lifting accessory to avoid injury to personnel!	
8	Raise the lifting equipment to take the weight of the upper arm.	
9	Remove the <i>balancing device</i> .	Detailed in section Replacing the balancing device on page 234
10	Remove the <i>linkage</i> .	Detailed in section Replacement of linkage - upper rod on page 198 Detailed in section Replacing the linkage - lower rod on page 202 Detailed in section Replacement of linkage - link on page 206
11	Remove the <i>parallel rod</i> .	Detailed in section Replacing the parallel rod on page 214

Continues on next page

4 Repair

4.4.3 Replacement of upper arm



Continued

	Action	Note
12	Remove the shaft, axis 3 (B): 1 Remove the <i>lock nut</i> (K). 2 Remove the <i>set screw</i> (C) holding the <i>shaft</i> . 3 Put the <i>adapter</i> on the <i>shaft</i> . 4 Remove the shaft.	Shown in the figure View of the assembly of the upper arm components on page 189 . Perform the removal with care. Threads can otherwise be damaged! Art.no. is specified in Required equipment on page 190
13	Then remove the <i>shaft, axis 2</i> (A) in the same order: 1 Remove the <i>lock nut</i> (K) 2 Remove the <i>set screw</i> (C) holding the shaft 3 Remove the <i>shaft axis 2</i> .	Shown in the figure View of the assembly of the upper arm components on page 189 .  Note The adapter is not needed on this shaft!
14	Put the <i>shafts</i> in a clean and safe place.	
15	Remove the <i>upper arm</i> .	

Continues on next page

Preparations before refitting, upper arm

The procedure below details the preparations which must be done before refitting the upper arm.

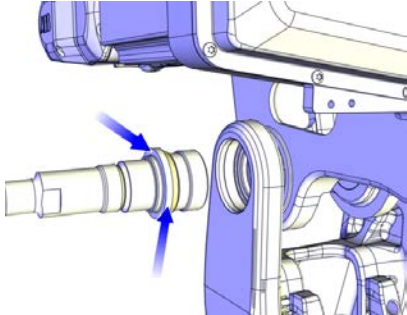
	Action	Note
1	<p>Prepare the shafts:</p> <ul style="list-style-type: none"> • Put the <i>shafts</i> (A & B) on a workbench and fit the <i>sealing rings</i> (E). • Lubricate the sealing rings with grease. • Apply some grease on the <i>shafts</i>. <p> Note</p> <p>Don't apply grease on the threads and cones of the shafts!</p> <ul style="list-style-type: none"> • Apply <i>lubricant paste</i> (D) on the threads and cones of the <i>shafts</i>. Molycote 1000. • <i>Foundry Plus</i>: Apply rust preventive on the surfaces on the shaft, according to illustration. <p> Note</p> <p>Apply rust preventive to the shafts on both sides of the robot.</p>  <p>xx1400001124</p>	<p>Shown in the figure View of the assembly of the upper arm components on page 189.</p>
2	<p>Prepare the bearings:</p> <p>Fill the <i>bearings</i> (G) with bearing grease.</p> <p>Use grease filling tool.</p>	<p>Art. no. is specified Required equipment on page 190</p> <p>Shown in the figure View of the assembly of the upper arm components on page 189.</p>

Continues on next page

4 Repair

4.4.3 Replacement of upper arm

Continued

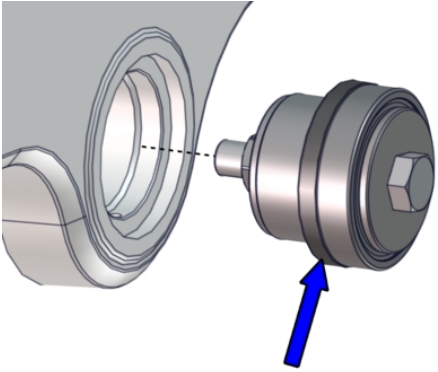
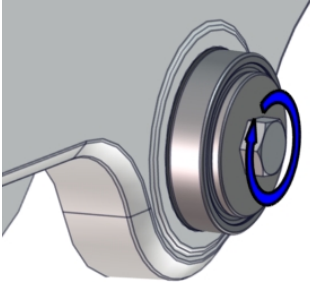
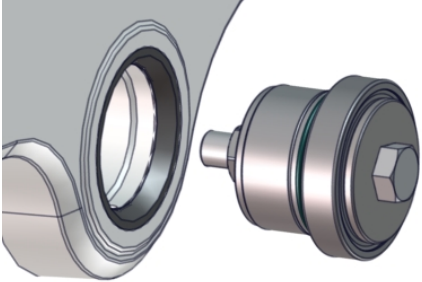

	Action	Note
3	<p>Install two support rings to the upper arm:</p> <ol style="list-style-type: none"> 1 Fit a support ring to the press tool and lubricate with grease for easier assembly. 2 Press in the support ring to the upper arm housing by screwing on the press tool assembly. Tighten with 120 Nm. 3 Remove the press tool. The support ring is now fitted to the upper arm housing. 4 Repeat the procedure on the other side. <p> CAUTION</p> <p>If the support ring is mounted askew, there is a risk of play between the shaft and the upper arm. Make sure the support rings are aligned correctly (level) inside the upper arm housing.</p>	<p>Art. no. is specified Required equipment on page 190</p>  <p>xx1900001713</p>  <p>xx1900001714</p>  <p>xx1900001205</p>

Refitting, upper arm

The procedure below details how to refit the upper arm.

	Action	Note
1	Secure the <i>upper arm</i> with roundslings in an overhead crane.	
2	<p> CAUTION</p> <p>The complete upper arm with weighs 170 kg (without any additional equipment fitted). Use a suitable lifting accessory to avoid injury to personnel!</p>	

Continues on next page

	Action	Note
3	Lift the <i>upper arm</i> with an overhead crane and move it to its mounting position. Make sure that the <i>upper arm</i> is placed in a horizontal position.	
4	 Note Refit the axis 3 side first!	
5	Refit the axis-3 shaft: <ol style="list-style-type: none"> 1 Carefully refit the <i>shaft, axis 3 (B)</i> by hand only. Do not use force since the threads can be damaged if fitting is not done in the correct way. 2 Put the <i>adapter</i> on the <i>shaft</i> and fit it. Secure the shaft. Tightening torque: 800 Nm. 3 Refit the <i>sealing ring (F)</i> on the <i>shaft</i>. 4 Refit the <i>bearing (G)</i> on the <i>shaft</i> with the pressing tool, upper arm. 5 Fit an <i>o-ring (H)</i> on the <i>sealing ring (I)</i> and fit it on the <i>shaft</i>.  Note The o-ring shall be faced against the <i>bearing</i> . <ol style="list-style-type: none"> 6 Fit the <i>o-ring (L)</i> on the <i>sealing assembly (J)</i> and refit the <i>sealing assembly</i> on the <i>shaft</i>. 7 Apply locking liquid (Loctite 243) on the <i>lock nut (K)</i> and refit it using a <i>KM12 socket</i>. Tightening torque 90 Nm. 	Shown in the figure View of the assembly of the upper arm components on page 189 . Art. no. is specified Required equipment on page 190 Loctite 243.

Continues on next page

4 Repair

4.4.3 Replacement of upper arm

Continued

	Action	Note
6	<p>Refit the axis-2 shaft:</p> <ol style="list-style-type: none"> 1 Carefully refit the <i>shaft, axis 2 (A)</i> by hand only. Do not use force since the threads can be damaged if fitting is not done in the correct way. 2 Secure the shaft. Tightening torque: 800 Nm. 3 Refit the <i>sealing ring (F)</i> on the <i>shaft</i>. 4 Refit the <i>bearing (G)</i> on the <i>shaft</i> with the pressing tool, upper arm. 5 Fit an <i>o-ring (H)</i> on the <i>sealing ring (I)</i> and fit it on the <i>shaft</i>. <p> Note</p> <p>The o-ring shall be faced against the <i>bearing</i>.</p> <ol style="list-style-type: none"> 6 Fit the <i>o-ring (L)</i> on the <i>sealing assembly (J)</i> and refit the <i>sealing assembly</i> on the <i>shaft</i>. 7 Apply locking liquid (Loctite 243) on the <i>lock nut (K)</i> and refit it using a <i>KM12 socket</i> in three steps: <ol style="list-style-type: none"> a Fit the <i>lock nut</i> with a tightening torque of 300 Nm. b Unscrew the <i>lock nut</i>. c Fit the <i>lock nut</i> once again. This time with a tightening torque of 90 Nm. 	<p>Shown in the figure View of the assembly of the upper arm components on page 189. Art. no. is specified Required equipment on page 190 Loctite 243.</p>
7	<p>Apply locking liquid in the holes for the <i>set screws (C)</i> and fit the screws.</p>	<p>Shown in the figure View of the assembly of the upper arm components on page 189 Loctite 243. Tightening torque: 35 Nm.</p>
8	<p>Wipe residual grease from the <i>shafts</i>.</p>	
9	<p>Refit the parallel rod.</p>	<p>Detailed in section Replacing the parallel rod on page 214</p>
10	<p>Refit the <i>cable harness, upper end</i>.</p>	<p>Detailed in section</p>
11	<p>Refit the <i>linkage</i>.</p>	<p>Detailed in section Replacement of linkage - upper rod on page 198 Detailed in section Replacing the linkage - lower rod on page 202 Detailed in section Replacement of linkage - link on page 206</p>
12	<p>Refit the <i>balancing device</i>.</p>	<p>Detailed in section Replacing the balancing device on page 234</p>
13	<p>Recalibrate the robot.</p>	<p>Axis Calibration is described in Calibrating with Axis Calibration method on page 314. General calibration information is included in section Calibration on page 303.</p>

Continues on next page

	Action	Note
14	 DANGER Make sure all safety requirements are met when performing the first test run.	

4 Repair

4.4.4 Replacement of linkage - upper rod

4.4.4 Replacement of linkage - upper rod

Overview

The link system consists of three basic parts - upper rod, lower rod and link. These procedures describes how to remove and refit the upper rod.

Location of upper rod

The upper rod is located as shown in the figure below.

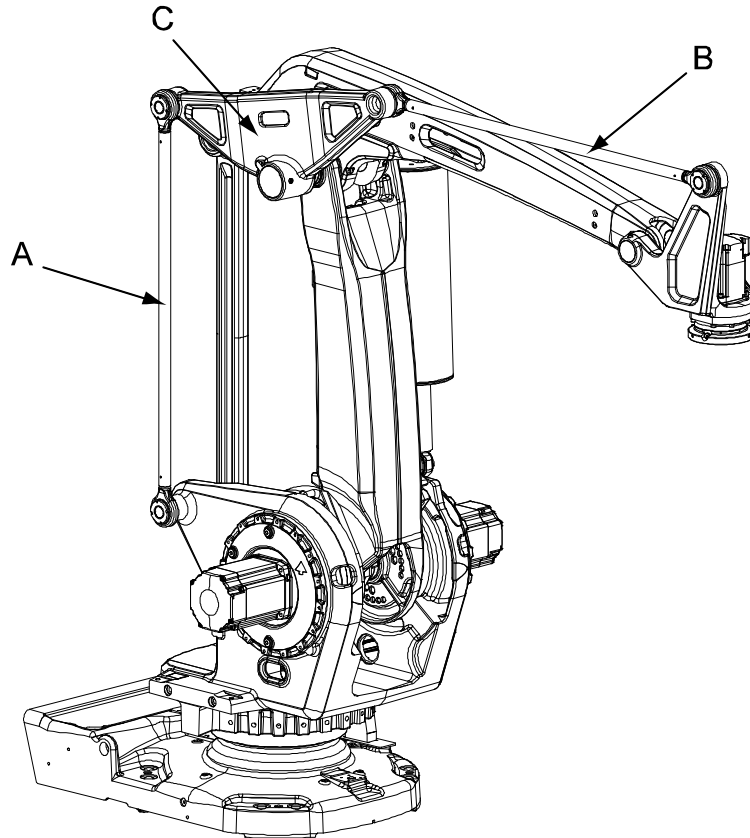

xx0600002592

A	Lower rod
B	Upper rod
C	Link

Required equipment



Equipment	Spare part no.	Art no.	Note
Upper rod	3HAC023744-003		White RAL 9003
Needle bearing	3HAC3311-1		Replace if damaged.
Bearing grease		3HAC042536-001	Shell Gadus S2 Used to lubricate the bearings.
Locking liquid		3HAB7116-1	Loctite 243

Continues on next page

Equipment	Spare part no.	Art no.	Note
Standard toolkit		-	Content is defined in section Standard tools on page 346 .
Other tools and procedures may be required. See references to these procedures in the step-by-step instructions below.			These procedures include references to the tools required.

Removal, upper rod

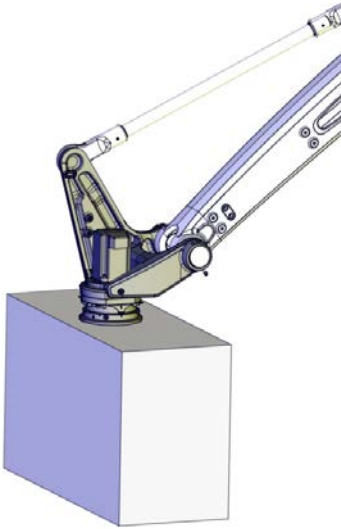
The procedure below details how to remove the upper rod of the linkage.



	Action	Note
1	Put the robot in a position where it is possible to reach all parts that shall be removed.	Check especially that it is possible to remove the lock nut at the link.
2	Let the <i>tilthouse</i> rest on a workbench, on some pallets or similar. This is done in order to prevent the tilthouse from falling downwards when the upper rod is removed.	 <p>xx1000001132</p>
3	 DANGER Turn off all: <ul style="list-style-type: none"> • electric power supply • hydraulic pressure supply • air pressure supply to the robot, before entering the robot working area.	

Continues on next page

4 Repair

4.4.4 Replacement of linkage - upper rod

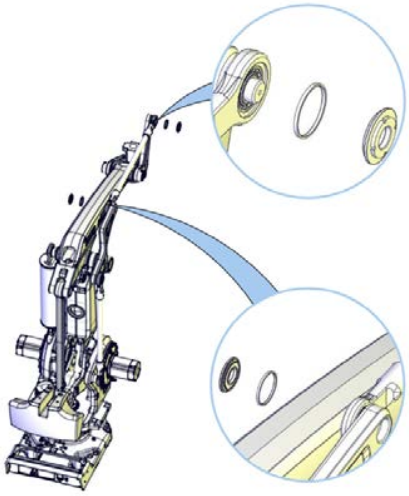
Continued

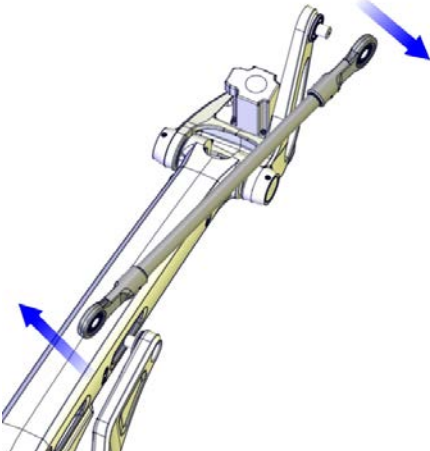

	Action	Note
4	Remove the <i>lock nuts</i> and <i>support washers</i> holding the upper rod at each end.	 <p>xx1000001080</p>
5	Remove the upper rod as shown in the figure.  Note The support washers on the inside of the rod can stick to the grease of the bearings when the rod is being removed. Remove them from the link arm!	 <p>xx1000001081</p>
6	Remove the <i>support washers</i> and the <i>sealing rings</i> .	
7	Remove residual grease.	

Refitting, upper rod

The procedure below details how to refit the upper rod of the linkage.

	Action	Note
1	If needed, replace the <i>bearings</i> in the rod.  Note The bearings are sensitive for pushes. Make sure they are not damaged!	Spare part no. is specified in Required equipment on page 198 .

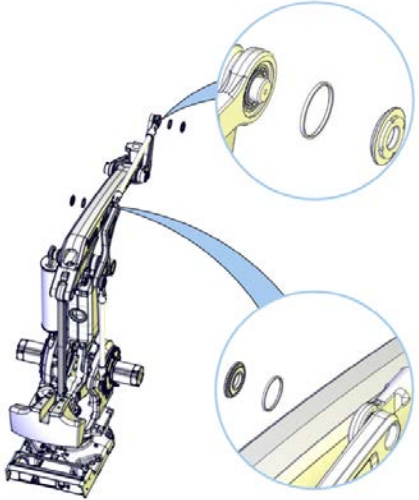
Continues on next page

	Action	Note
2	Lubricate the bearings properly with <i>bearing grease</i> .	Specified in <i>Required equipment on page 198</i> .
3	Refit the <i>sealing rings</i> on the shaft ends of the link and tilthouse.	
4	Refit the <i>support washers</i> on the shaft ends.	
5	Lubricate the shaft ends lightly with grease.	
6	Refit the upper rod to its place on the shafts.	Check that the rod is pushed in completely.
7	Refit the <i>support washers</i> on the outside of the upper rod on the shaft ends.	 <p data-bbox="991 1162 1094 1182">xx1000001080</p> <p data-bbox="1059 1200 1318 1261">Lock nut (2 pcs) Support washer (2 pcs)</p>
8	Apply <i>locking liquid</i> on the threads for the lock nuts.	
9	Refit the <i>lock nuts</i> on the link and tilthouse, using <i>locking liquid</i> .	Tightening torque: 120 Nm.
10	 <p data-bbox="580 1453 687 1480">DANGER</p> <p data-bbox="491 1514 959 1570">Make sure all safety requirements are met when performing the first test run.</p>	

4 Repair

4.4.5 Replacing the linkage - lower rod

4.4.5 Replacing the linkage - lower rod

Overview

The linkage consists of three basic parts - upper rod, lower rod and link. The procedures below details how to remove and refit the lower rod.

How to replace the upper rod and link, see:

- [Replacement of linkage - upper rod on page 198.](#)
- [Replacement of linkage - link on page 206](#)

Location of lower rod

The lower rod is located as shown in the figure below.

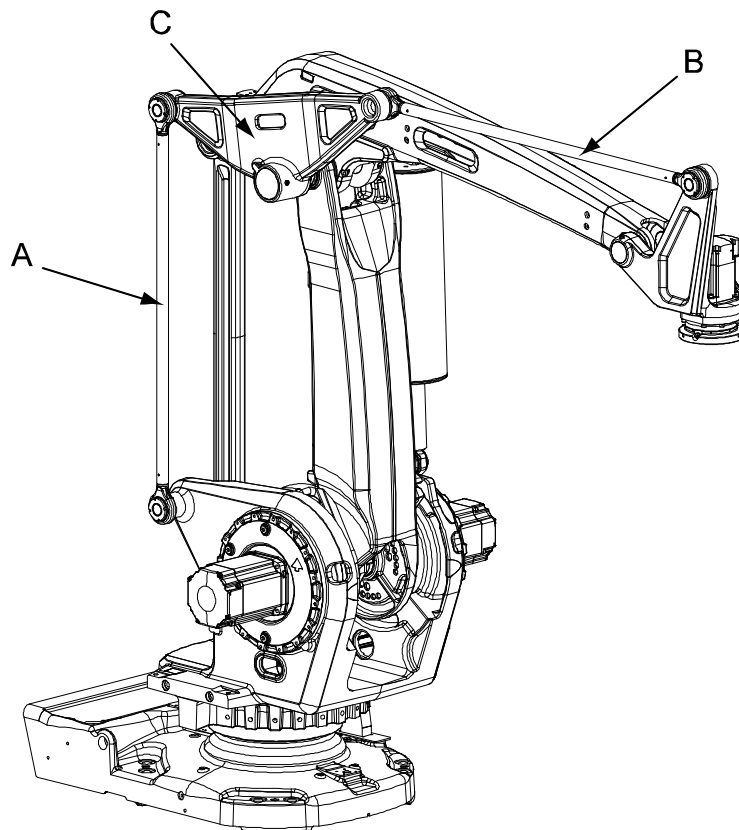

xx0600002592

A	Lower rod
B	Upper rod
C	Link

Required equipment

Equipment	Art no.	Note
Lower rod	For spare part no. see: <ul style="list-style-type: none">• Spare part lists on page 351	

Continues on next page

Equipment	Art no.	Note
Needle bearing	For spare part no. see: <ul style="list-style-type: none"> • Spare part lists on page 351 	Replace if damaged.
Bearing grease	3HAC042536-001	Shell Gadus S2
Locking liquid	3HAB7116-1	Loctite 243
KM10 socket	-	Standard
Standard toolkit		Content is defined in section Standard tools on page 346 .
Other tools and procedures may be required. See references to these procedures in the step-by-step instructions below.		These procedures include references to the tools required.

Removal, lower rod

Use this procedure to remove the lower rod of the linkage.

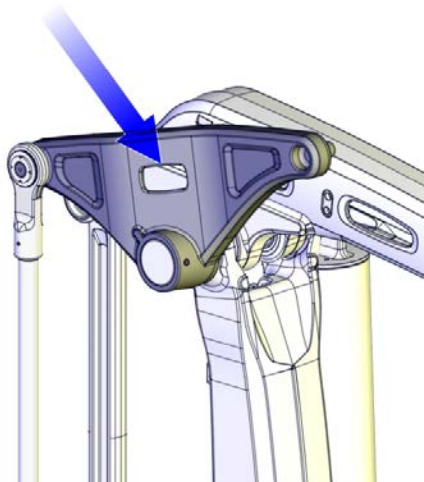

Action	Note
<p>1</p>  <p>DANGER</p> <p>Turn off all:</p> <ul style="list-style-type: none"> • electric power supply • hydraulic pressure supply • air pressure supply <p>to the robot, before entering the robot working area.</p>	
<p>2</p> <p>If the upper rod is removed, secure the link with a roundsling in a crane. Use the hole in the middle of the link.</p>	 <p>xx1000001252</p> <p>This is done in order to prevent the link from moving if both the upper rod and lower rod are removed.</p>

Continues on next page

4 Repair



4.4.5 Replacing the linkage - lower rod

Continued



	Action	Note
3	<p>Remove the <i>lock nuts</i> and <i>support washers</i> that hold the lower rod at each end.</p> <p> Note</p> <p>The support washers can stick to the grease and can easily be forgotten and lost when removing the lock nuts.</p>	
4	<p> CAUTION</p> <p>The link weighs . All lifting accessories used must be sized accordingly!</p>	
5	<p>Remove the lower rod by lifting it straight out.</p> <p> Note</p> <p>The support washers on the inside of the rod can stick to the grease of the bearings when the rod is being removed. Remove them from the rod!</p>	
6	Remove the inner <i>support washers</i> and the <i>sealing/spacer rings</i> .	
7	Remove residual grease.	

Refitting, lower rod

Use this procedure to refit the lower rod of the linkage.

	Action	Note
1	<p>If needed, replace the <i>bearings</i>.</p> <p> Note</p> <p>The bearings are sensitive for pushes. Make sure they are not damaged!</p>	Spare part no. is specified in Required equipment on page 202 .
2	Lubricate the bearings properly with <i>bearing grease</i> .	Specified in Required equipment on page 202 .
3	Refit the <i>sealing/spacer rings</i> to the shaft ends on the link and frame.	
4	Refit the <i>support washers</i> on the sealing/spacer rings.	<p>Replace if damaged.</p> <p> Tip</p> <p>Putting some grease on the support washers will keep them in position.</p>
5	Check that the bearings in the lower rod are fitted correctly, that is in the center of the hole. (The same distance from bearing to the edge of the lower rod on both sides.)	

Continues on next page

	Action	Note
6	 CAUTION The link weighs . All lifting accessories used must be sized accordingly!	
7	Place the lower rod on the shaft ends of the link and frame.  Note Check that the lower rod is pushed completely in.	
8	Refit the support washers on the outside of the lower rod, on the link and frame shafts.	
9	Apply <i>locking liquid</i> on the threads of the lock nuts.	Specified in Required equipment on page 202 .
10	Refit the lock nuts on the shaft ends. Use a KM10 socket.	Tightening torque: 120 Nm.
11	 DANGER Make sure all safety requirements are met when performing the first test run.	

4 Repair

4.4.6 Replacement of linkage - link

4.4.6 Replacement of linkage - link

Overview

The linkage consists of three basic parts - upper rod, lower rod and link. The procedures below details how to remove and refit the link.

How to replace the upper rod and lower rod, see:

- [Replacement of linkage - upper rod on page 198.](#)
- [Replacing the linkage - lower rod on page 202.](#)

Location of link

The link is located as shown in the figure.

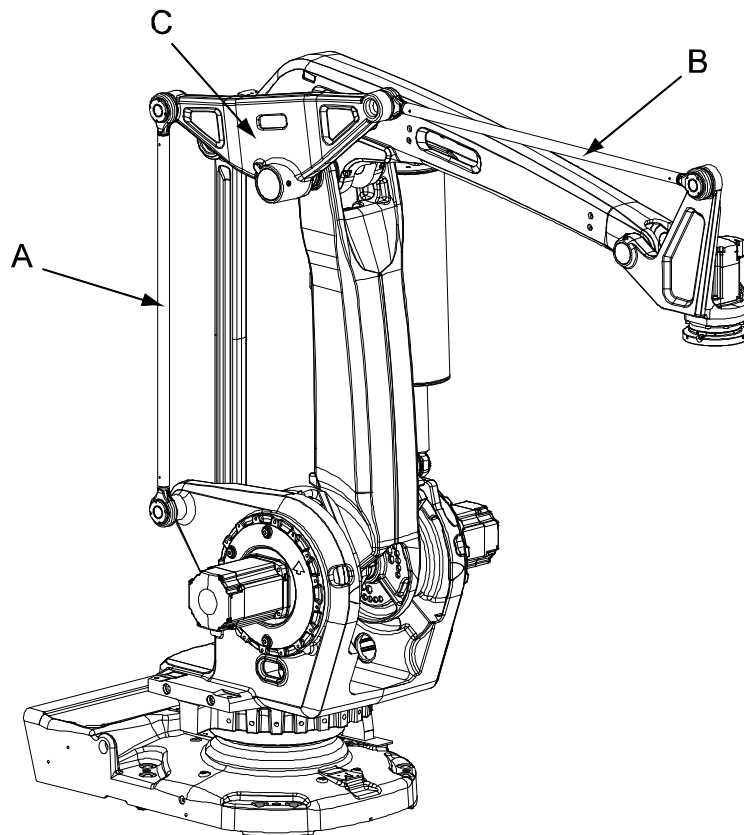

xx0600002592

A	Lower rod
B	Upper rod
C	Link

Cut away view of the assembly of the link

The figure shows a cut view of how the link is fitted.

Continues on next page

Required equipment

Equipment, etc.	Art. no.	Note
Link	For spare part no. see: <ul style="list-style-type: none"> • Spare part lists on page 351 	
Auxiliary shaft	3HAC023081-004	Used for bearings.
Pressing tool, link	3HAC023081-001	Hydraulic pressing accessory used to press the the link on the shaft User instructions are enclosed with the tool.
Pressing tool, link	3HAC077981-001	Hydraulic pressing accessory used to press the outer rings of the bearings in the link. User instructions are enclosed with the tool.
Lubrication tool	3HAC5222-2	
Sealing compound	3HAC073510-001	Trans7
Locking liquid	3HAB7116-1	Loctite 243
Grease	3HAC042536-001	Shell Gadus S2
Standard toolkit		Content is defined in section Standard tools on page 346 .
Other tools and procedures may be required. See references to these procedures in the step-by-step instructions below.		These procedures include references to the tools required.

Deciding calibration routine

Decide which calibration routine to be used, based on the information in the table. Depending on which routine is chosen, action might be required prior to beginning the repair work of the robot, see the table.

	Action	Note
1	Decide which calibration routine to use for calibrating the robot. <ul style="list-style-type: none"> • Reference calibration. External cable packages (DressPack) and tools can stay fitted on the robot. • Fine calibration. All external cable packages (DressPack) and tools must be removed from the robot. 	
	If the robot is to be calibrated with reference calibration: Find previous reference values for the axis or create new reference values. These values are to be used after the repair procedure is completed, for calibration of the robot. If no previous reference values exist, and no new reference values can be created, then reference calibration is not possible.	Follow the instructions given in the reference calibration routine on the FlexPendant to create reference values. Creating new values requires possibility to move the robot. Read more about reference calibration for Axis Calibration in <i>Product manual - IRB 4600</i> .

Continues on next page

4 Repair

4.4.6 Replacement of linkage - link

Continued



Action	Note
<p>If the robot is to be calibrated with fine calibration: Remove all external cable packages (DressPack) and tools from the robot.</p>	

Removal, link

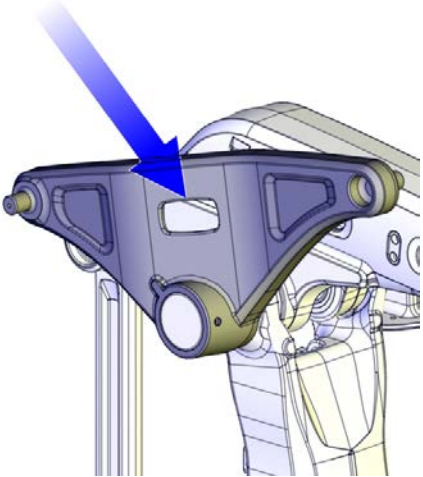
Use this procedure to remove the link of the linkage.

Action	Note
1	Decide which calibration routine to use, and take actions accordingly prior to beginning the repair procedure.
2	<p> DANGER</p> <p>Turn off all:</p> <ul style="list-style-type: none"> • electric power supply • hydraulic pressure supply • air pressure supply <p>to the robot, before entering the robot working area.</p>
3	<p>Secure the link with a roundsling in a crane. Use the hole in the middle of the link. This is done to prevent the link from moving when the upper rod and lower rod are removed.</p>  <p>xx1000001265</p>
4	<p>Remove the upper rod and lower rod.</p> <p>Detailed in section Replacement of linkage - upper rod on page 198 Detailed in section Replacing the linkage - lower rod on page 202</p>
5	<p>Fit the auxiliary shaft on the shaft.</p> <p>Art.no. is specified in Required equipment on page 207</p>

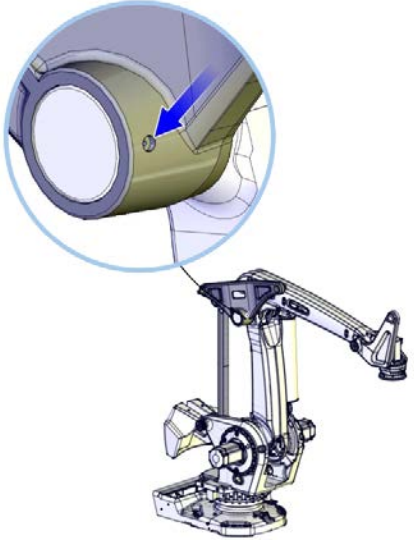
Continues on next page

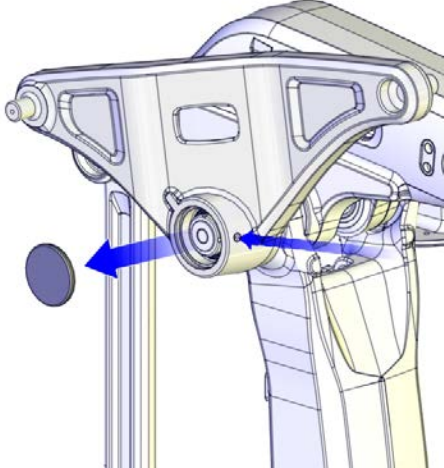

	Action	Note
6	<p>Remove <i>screw and washer</i> in the hole for filling grease.</p>	 <p>xx1000001266</p>
7	<p>Use compressed air to remove the <i>VK cover</i>. Blow with a very low air pressure into the hole for filling grease.</p> <p> CAUTION</p> <p>Only a very low air pressure is needed!</p>	 <p>xx1000001267</p> <p>Put one hand with some paper on top of the <i>VK cover</i> in order to catch it when released.</p>

Continues on next page

4 Repair

4.4.6 Replacement of linkage - link

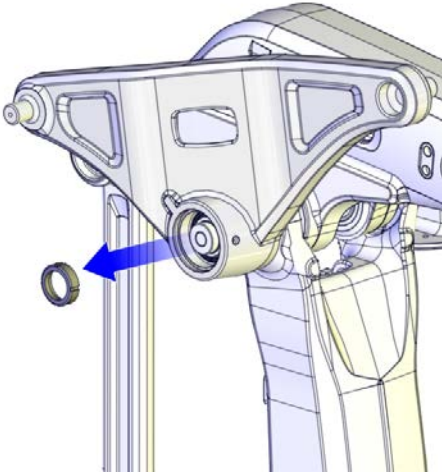

Continued

	Action	Note
8	Remove the <i>lock nut (KM8)</i> .	 <p>xx1000001268</p>
9	 CAUTION The link weighs approximately . All lifting accessories used must be sized accordingly!	
10	Put the end of the link facing the upper rod, downwards in order to find room to knock on it from the inside as close to its center as possible.	Normally a not too hard knock is needed to loosen the link. Note! Loosen the roundsling some before knocking! Otherwise the link may be locked by the lifting power.
11	Use a pair of levers, to bend the link loose.	
12	Remove the link.	
13	Remove the <i>support ring with the radial seal</i> .	
14	Wipe off residual grease.	
15	If needed, replace the bearings and radial seal.	

Fitting outer races of the bearing and sealing in the link

	Action	Note
1	Put the link on a workbench.	

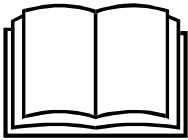
Continues on next page

	Action	Note
2	<p>Fit the new <i>outer races</i> using the mounting tool.</p>  <p>xx0900000813</p> <p>Go to the user instructions enclosed with the press tool.</p> <p> DANGER</p> <p>Handling the tool incorrectly will cause serious injury.</p> <p>Read and follow enclosed user instructions for the tool.</p>	<p>Art.no. is specified in Required equipment on page 207</p>

Refitting, link

Use this procedure to refit the link of the linkage.



	Action	Note
1	<p> CAUTION</p> <p>The link weighs . All lifting accessories used must be sized accordingly!</p>	
2	<p>Secure the link with a roundsling in an overhead crane and lift it to the mounting position.</p>	
3	<p>Fit the <i>auxiliary shaft</i> on the shaft.</p>	<p>Art.no. is specified in Required equipment on page 207</p>
4	<p>Apply sealing compound on the support ring.</p>	<p>Sealing compound: 3HAC073510-001 (Trans7).</p>
5	<p>Fit the support ring, with the radial seal fitted, on the shaft.</p>	<p>Replace the radial seal if needed!</p>
6	<p>Lubricate and place the bearings and link on the shaft, in the following order:</p> <ul style="list-style-type: none"> • bearing • link • bearing 	

Continues on next page

4 Repair

4.4.6 Replacement of linkage - link

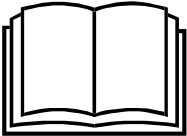
Continued

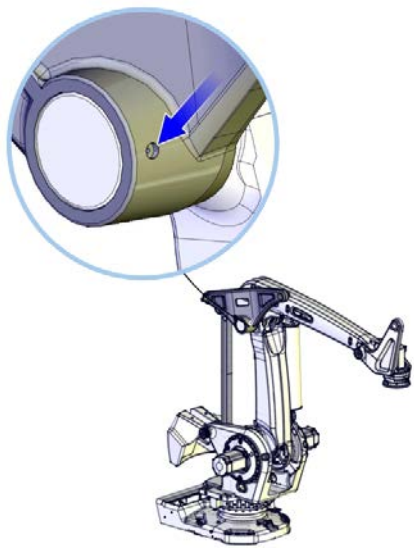
	Action	Note
7	<p>Fit the new <i>outer races</i> using the mounting tool.</p>  <p>xx0900000813</p> <p>Go to the user instructions enclosed with the press tool.</p> <p> DANGER</p> <p>Handling the tool incorrectly will cause serious injury. Read and follow enclosed user instructions for the tool.</p>	<p>Art.no. is specified in Required equipment on page 207</p>
8	<p>Apply <i>locking liquid</i> on the lock nut.</p>	<p>Loctite 243</p>
9	<p>Secure the lock nut in these three steps:</p> <ol style="list-style-type: none"> 1 Tighten with a torque of 300 Nm. 2 Unscrew the lock nut. 3 Tighten the lock nut finally with a tightening torque of 90 Nm. <p> Note</p> <p>The recommended order of tightening the lock nut is important to follow to avoid future problems with the shaft.</p>	
10	<p>Refit the VK cover.</p>	
11	<p>Fill the link with <i>grease</i>. Use lubrication tool.</p>	<p>Art.no. is specified in Required equipment on page 207</p>  <p>xx1000001266</p>
12	<p>Refit the screw and washer in the hole for filling grease.</p>	

Continues on next page

	Action	Note
13	Refit the upper rod to the link.	Detailed in section Replacement of linkage - upper rod on page 198
14	Refit the upper rod to the link.	Detailed in section Replacing the linkage - lower rod on page 202
15	Recalibrate the robot!	Axis Calibration is described in Calibrating with Axis Calibration method on page 314 . General calibration information is included in section Calibration on page 303 .
16	 DANGER Make sure all safety requirements are met when performing the first test run.	

4 Repair

4.4.7 Replacing the parallel rod

4.4.7 Replacing the parallel rod

Location of parallel rod

The parallel rod is located as shown in the figure.

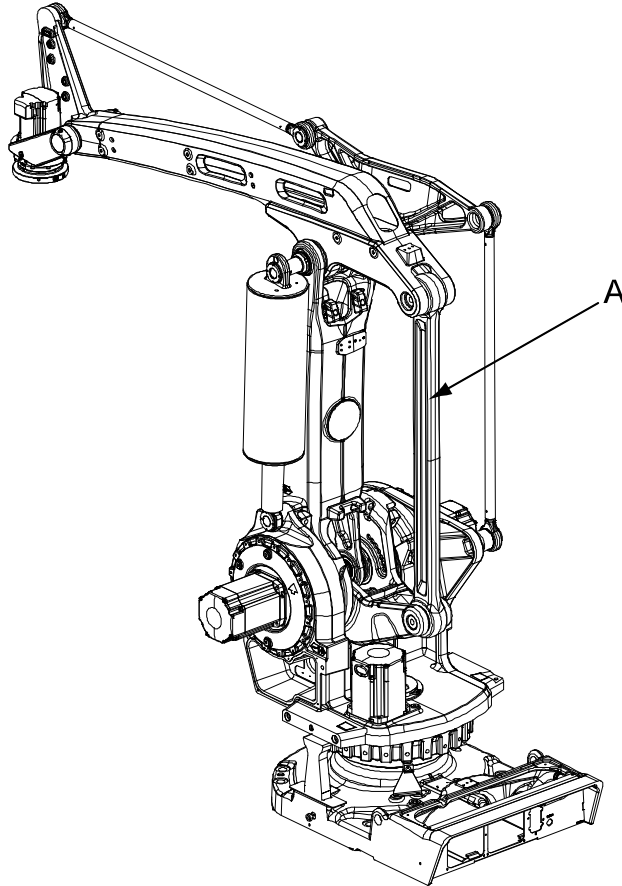

xx0600002610

A	Parallel rod
---	--------------

Required equipment



Equipment, etc.	Art.no.	Note
Parallel rod	For spare part no. see: <ul style="list-style-type: none">• Spare part lists on page 351.	
Mounting/Demounting tool	3HAC5021-1	
Locking liquid	3HAB7116-1	Loctite 243
Rust preventive	3HAC034903-001	Mercasol 3110 Waxcoat
Protection plug	3HAC4836-2	F21 28x22, 4x12x9
Standard toolkit	-	Content is defined in section Standard tools on page 346.

Continues on next page

Equipment, etc.	Art.no.	Note
Other tools and procedures may be required. See references to these procedures in the step-by-step instructions below.		These procedures include references to the tools required.

Removing, parallel rod

Use this procedure to remove the parallel rod. The procedure is the same in both ends of the parallel rod.

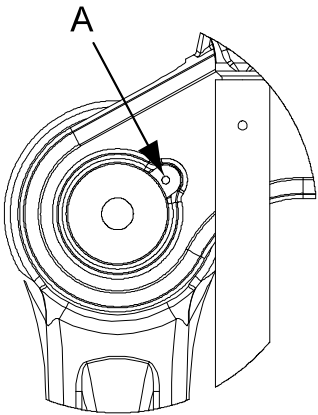

	Action	Note
1	 DANGER Turn off all: <ul style="list-style-type: none"> • electric power supply • hydraulic pressure supply • air pressure supply to the robot, before entering the robot working area.	
2	 CAUTION Secure the upper arm with a roundsling in an overhead crane or similar, in order to avoid accidents.	
3	<i>Foundry Plus:</i> Remove the protection plugs	
4	Remove the upper <i>lock screw</i> and <i>washer</i> , that secure the parallel rod in position.	 <p>xx0600002741</p> <ul style="list-style-type: none"> • A: Lock screw M6x16

Continues on next page

4 Repair

4.4.7 Replacing the parallel rod

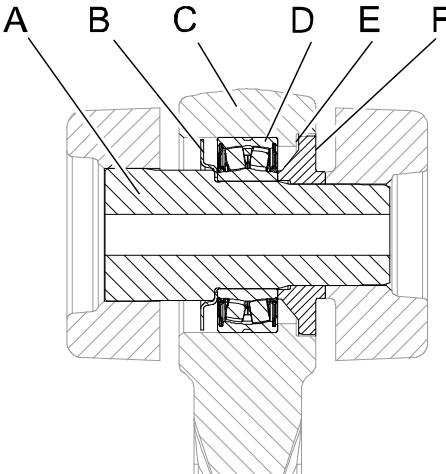

Continued

	Action	Note
5	Remove the upper <i>shaft</i> (A) and <i>cover washer</i> (B), using the <i>fitting/removing tool</i> .	Art. no. is specified in Required equipment on page 214 .  xx0700000065 Parts: A Shaft B Cover washer C Parallel rod D Sealed spherical bearing E Bearing grease F Thrust washer
6	Remove the <i>thrust washer</i> (F).	See figure above!
7	 CAUTION The parallel rod weighs . All lifting accessories used must be sized accordingly!	
8	Move the <i>parallel rod</i> backwards from its upper connection point and let it rest against the frame and base.	See figure above and Location of parallel rod on page 214 !
9	Secure the parallel rod with a roundsling in an overhead crane or similar.	
10	Remove the lower end of the parallel rod in the same way as the upper end: 1 Remove the lower <i>lock screw</i> and <i>washer</i> . 2 Remove the lower <i>shaft</i> (A) and <i>cover washer</i> (B). 3 Remove the <i>thrust washer</i> (F).	See figure above!
11	Remove the parallel rod from the robot.	
12	Replace the <i>bearings</i> (D), if necessary.	See figure above!

Continues on next page

Refitting, parallel rod

Use this procedure to refit the parallel rod. The procedure is the same in both ends of the parallel rod.

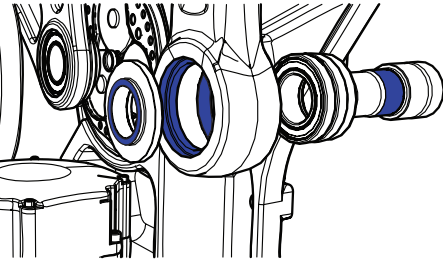
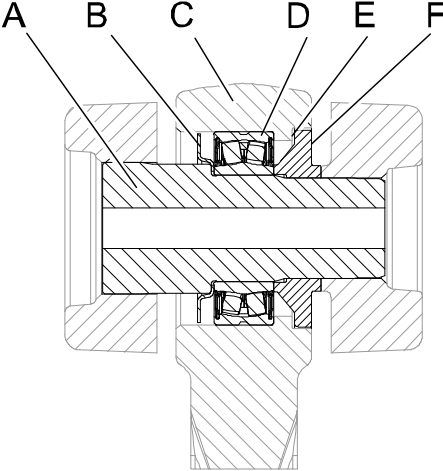

	Action	Note
1	Start by refitting the lower end.	
2	Verify that the bearings are in correct position in the parallel rod.	
3	 CAUTION The parallel rod weighs . All lifting accessories used must be sized accordingly!	
4	Lift the parallel rod to the mounting position of the lower end, and let it rest on the the frame and base.	
5	<p><i>Foundry Plus:</i> Apply rust preventive on the highlighted areas.</p>  Note Rust preventive should be applied in both ends of the parallel rod.	 xx1400001126
6	Put the <i>thrust washer</i> (F) on the axis 2 side of the <i>parallel rod</i> (C).	 xx0700000065 Parts: A Shaft B Cover washer C Parallel rod D Sealed spherical bearing E Bearing grease F Thrust washer
7	Put the <i>cover washer</i> (B) on the axis 3 side of the parallel rod.	See figure above!

Continues on next page

4 Repair

4.4.7 Replacing the parallel rod

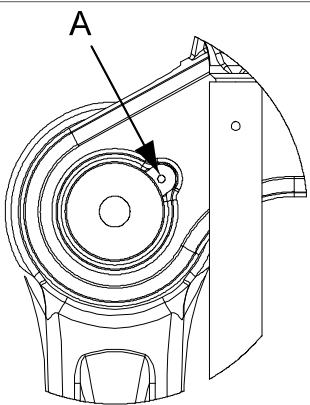
Continued

	Action	Note
8	Refit the <i>shaft</i> (A) by pressing it through the parallel bar with the <i>fitting/removing tool</i> .	Art. no. is specified in <i>Required equipment on page 214</i> . See figure above!
9	Apply <i>locking liquid</i> in the hole of the lock screw.	Loctite 243
10	Refit the <i>lock screw</i> and plain washer.	 xx0600002741 • A: Lock screw M6x16
11	Lift the parallel rod up into position for fitting the upper end.	
12	Refit the upper end of the parallel rod in the same way as the lower end.	
13	<i>Foundry Plus:</i> Refit the protection plugs.	
14	 DANGER Make sure all safety requirements are met when performing the first test run.	

4.4.8 Replacing the complete lower arm

Location of lower arm

The complete lower arm is located as shown in the figure below.

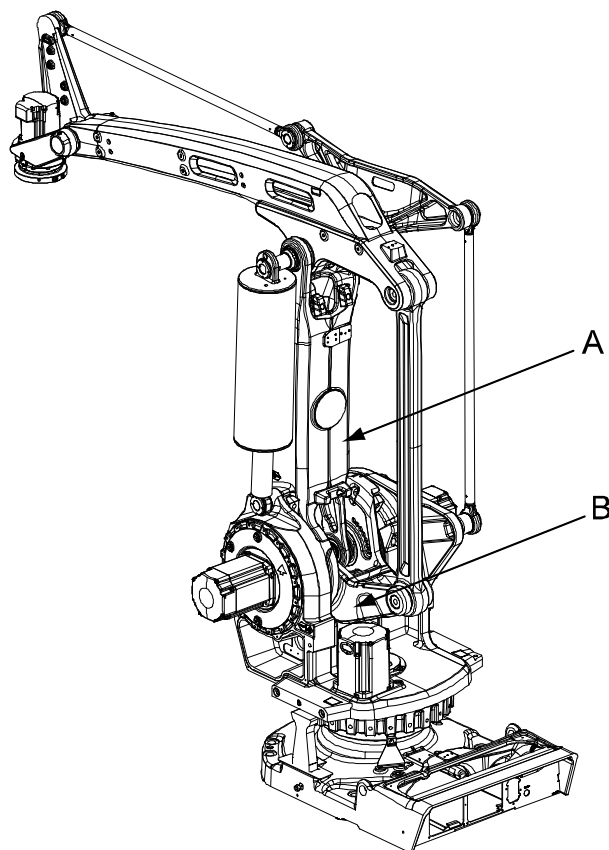

xx0600002611

A	Lower arm
B	Parallel arm

Required equipment

Equipment, etc.	Art.no.	Note
Lower arm	For spare part no. see: • Spare part lists on page 351.	
Sealing, axes 2/3		Always change the sealing.
Guide sleeves	3HAC14446-1	Used to keep the axes 2/3 sealing in place during refitting of lower arm.
Crank	3HAC023132-001	
Lock screw	-	M16x90
Lifting tool, lower arm complete	3HAC8446-1	

Continues on next page

4 Repair

4.4.8 Replacing the complete lower arm

Continued

Equipment, etc.	Art.no.	Note
Standard toolkit	-	Content is defined in section Standard tools on page 346 .
Other tools and procedures may be required. See references to these procedures in the step-by-step instructions below.		These procedures include references to the tools required.
Circuit diagram		See chapter Circuit diagrams on page 353 .

Deciding calibration routine

Decide which calibration routine to be used, based on the information in the table. Depending on which routine is chosen, action might be required prior to beginning the repair work of the robot, see the table.





	Action	Note
1	Decide which calibration routine to use for calibrating the robot. <ul style="list-style-type: none"> Reference calibration. External cable packages (DressPack) and tools can stay fitted on the robot. Fine calibration. All external cable packages (DressPack) and tools must be removed from the robot. 	
	If the robot is to be calibrated with reference calibration: Find previous reference values for the axis or create new reference values. These values are to be used after the repair procedure is completed, for calibration of the robot. If no previous reference values exist, and no new reference values can be created, then reference calibration is not possible.	Follow the instructions given in the reference calibration routine on the FlexPendant to create reference values. Creating new values requires possibility to move the robot. Read more about reference calibration for Axis Calibration in <i>Product manual - IRB 4600</i> .
	If the robot is to be calibrated with fine calibration: Remove all external cable packages (DressPack) and tools from the robot.	

Removal, lower arm

The procedure below details how to remove the lower arm.

	Action	Note
1	Decide which calibration routine to use, and take actions accordingly prior to beginning the repair procedure.	

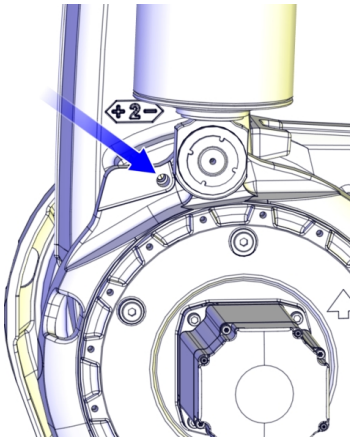
Continues on next page





	Action	Note
2	<p> DANGER</p> <p>Turn off all:</p> <ul style="list-style-type: none"> • electric power supply • hydraulic pressure supply • air pressure supply <p>to the robot, before entering the robot working area.</p>	
3	<p>Secure the lower arm with a <i>lock screw</i> in the hole as shown in the figure to the right.</p> <p> CAUTION</p> <p>Tighten by hand!</p>	 <p>xx1000001101</p>
4	Remove the linkage.	<p>See Replacement of linkage - upper rod on page 198</p> <p>See Replacing the linkage - lower rod on page 202</p> <p>See Replacement of linkage - link on page 206</p>
5	Remove the balancing device.	See Replacing the balancing device on page 234
6	Remove the parallel rod.	Also see
7	<p>Remove the cable harness in the upper and lower arm.</p> <p>Secure the cable harness in a way that it is protected from oil spill and damage.</p>	Also see
8	Remove the complete upper arm.	See Replacement of upper arm on page 188 .
9	Remove the axes 2 and 3 motors.	See Replacing motors, axes 2 and 3 on page 256 .
10	Remove the axes 2 and 3 gearboxes.	Also see
11	<p> CAUTION</p> <p>The robot lower arm weighs 65 kg.</p> <p>All lifting accessories used must be sized accordingly!</p>	

Continues on next page

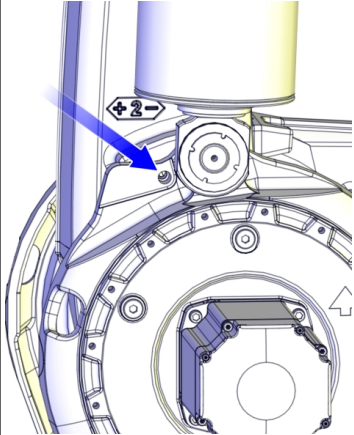

4 Repair

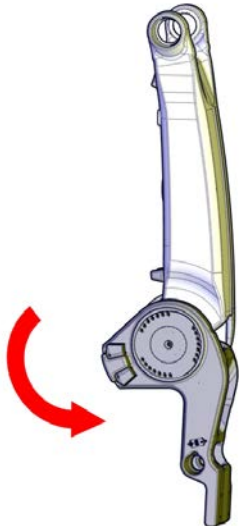
4.4.8 Replacing the complete lower arm

Continued

	Action	Note
12	Secure the complete lower arm system (including the parallel arm) with a <i>lifting tool</i> , <i>lower arm complete</i> in an overhead crane or similar.	Specified in <i>Required equipment on page 219</i> .
13	Remove the <i>lock screw</i> that secures the lower arm system.	 <p>xx1000001101</p>
14	Remove all M12 and M16 screws that hold the lower arm, on both sides.  Note The axis 3 side has no M16 screws!	
15	 DANGER Secure the parallel arm to the lower arm before lifting the lower arm system. If not secured, the parallel arm can fall down and cause a serious accident!	 <p>xx1000001359</p>
16	 CAUTION The parallel arm system weighs 118 kg. All lifting accessories used must be sized accordingly!	

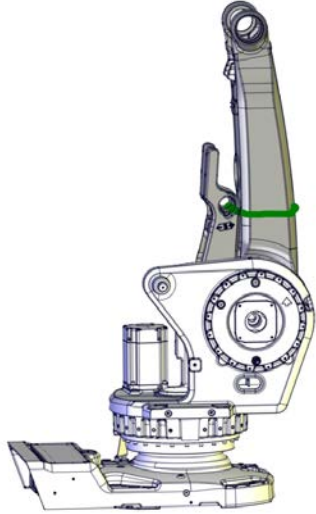
Continues on next page

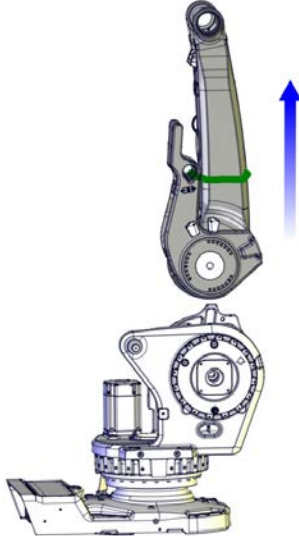
	Action	Note
17	Move the parallel arm and secure it to the lower arm as shown in the figure, to prevent it from falling down.	 <p>xx1000001357</p>
18	The space between the gearboxes is cramped. Push together the lower and parallel arm together with help of an iron bar or similar before removing them.	 Note If the parts are not pushed together, it will be difficult to remove the complete lower arm.
19	 CAUTION The robot lower arm weighs 65 kg. All lifting accessories used must be sized accordingly!	
20	Remove the complete lower arm (including the parallel arm).	 <p>xx1000001358</p>
21	How to replace the parallel arm is detailed in section Replacement of parallel arm on page 227 .	

Continues on next page



4 Repair

4.4.8 Replacing the complete lower arm



Continued

Refitting, lower arm

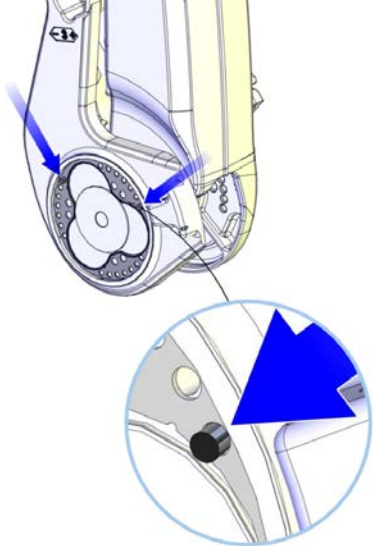
Use this procedure to refit the lower arm system.

	Action	Note
1	Fit the parallel arm to the lower arm.	See Replacement of parallel arm on page 227 .
2	 CAUTION The robot lower arm weighs 65 kg. All lifting accessories used must be sized accordingly!	
3	Fit a <i>lifting tool, lower arm complete</i> , to the lower arm system and lift it up.  DANGER Secure the parallel arm to the lower arm before lifting the lower arm system. If not secured, the parallel arm can fall down and cause a serious accident!	Specified in Required equipment on page 219 .
4	Fit two <i>guide sleeves</i> for the axes 2/3 sealings to the lower arm and put the sealings on them. See figure.	Art. no. is specified in Required equipment on page 219 .  xx1000001368

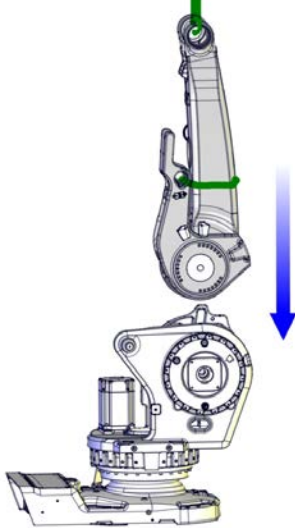
Continues on next page



	Action	Note
5	Put the lower arm in its mounting position. If the hole pattern needs to be adjusted, use a <i>crank</i> to move the gears in order to find the correct hole pattern.	Art. no. is specified in Required equipment on page 219 .  xx1000001370
6	 Note Refit the axis 2 side first!	
7	Verify that the sealings are still in place.	
8	Refit all screws (both M12 and M16) and washers, that are possible to fit at this stage, on the axis 2 side.	Tightening torque M16: 300 Nm Tightening torque M12: 120 Nm
9	Push the parallel arm against the axis 3 side with the help of an iron bar or similar.	
10	Refit all screws and washers, that are possible to fit, on the axis 3 side.  Note The axis 3 side has no M16 screws!	Tightening torque M12: 120 Nm
11	Remove the guide sleeves and secure two screws more.	
12	Change the position of the lower arm in order to reach the remaining attachment holes, and fit the remaining screws.	

Continues on next page

4 Repair

4.4.8 Replacing the complete lower arm

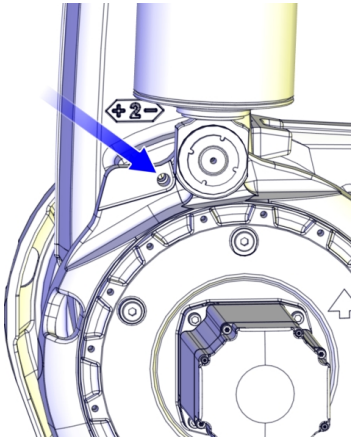
Continued

	Action	Note
13	Secure the lower arm by fitting a <i>lock screw</i> .  CAUTION Tighten by hand!	Dimension is specified in Required equipment on page 219 .  xx1000001101
14	Refit the axes 2 and 3 gearboxes.	See Replacing the gearbox, axes 2-3 on page 285 .
15	Refit the axes 2 and 3 motors.	See Replacing motors, axes 2 and 3 on page 256 .
16	Refit the complete upper arm.	See Replacement of upper arm on page 188 .
17	Refit the cable harness.	Also see
18	Refit the parallel rod.	See Replacing the parallel rod on page 214
19	Refit the balancing device.	Also see
20	Refit the linkage.	See Replacement of linkage - upper rod on page 198 See Replacing the linkage - lower rod on page 202 See Replacement of linkage - link on page 206
21	Remove the lock screw.	
22	Recalibrate the robot.	Axis Calibration is described in Calibrating with Axis Calibration method on page 314 . General calibration information is included in section Calibration on page 303 .
23	 DANGER Make sure all safety requirements are met when performing the first test run.	

4.4.9 Replacement of parallel arm

Location of parallel arm

The parallel arm is located as shown in the figure below.

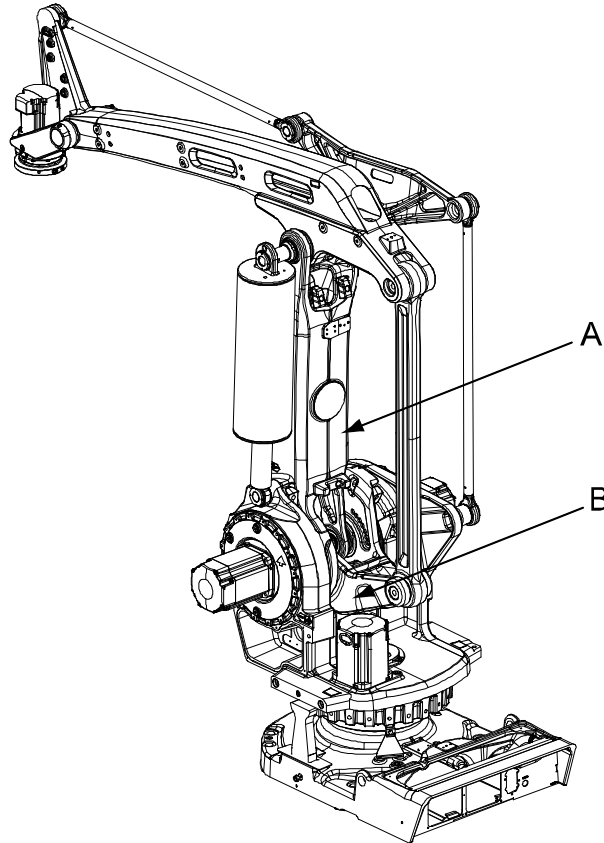

xx0600002611

A	Lower arm
B	Parallel arm

Required equipment

Equipment, etc.	Art.no.	Note
Parallel arm	For spare part no. see: • Spare part lists on page 351.	
VK cover		
VK cover		
Bearing grease	3HAC042536-001	Shell Gadus S2
Rust preventive	3HAC034903-001	Mercasol 3110 Waxcoat
Press equipment	3HAC076749-001	For replacing the bearings on parallel arm. User instructions are enclosed with the tool.

Continues on next page

4 Repair

4.4.9 Replacement of parallel arm

Continued

Equipment, etc.	Art.no.	Note
Lifting accessory, parallel arm	3HAC023098-001	
Lifting accessory, lower arm complete	3HAC8446-1	
Level	-	
Standard toolkit	-	Content is defined in section Standard tools on page 346 .
Other tools and procedures may be required. See references to these procedures in the step-by-step instructions below.		These procedures include references to the tools required.

Deciding calibration routine

Decide which calibration routine to be used, based on the information in the table. Depending on which routine is chosen, action might be required prior to beginning the repair work of the robot, see the table.





	Action	Note
1	Decide which calibration routine to use for calibrating the robot. <ul style="list-style-type: none">Reference calibration. External cable packages (DressPack) and tools can stay fitted on the robot.Fine calibration. All external cable packages (DressPack) and tools must be removed from the robot.	
	If the robot is to be calibrated with reference calibration: Find previous reference values for the axis or create new reference values. These values are to be used after the repair procedure is completed, for calibration of the robot. If no previous reference values exist, and no new reference values can be created, then reference calibration is not possible.	Follow the instructions given in the reference calibration routine on the FlexPendant to create reference values. Creating new values requires possibility to move the robot. Read more about reference calibration for Axis Calibration in <i>Product manual - IRB 4600</i> .
	If the robot is to be calibrated with fine calibration: Remove all external cable packages (DressPack) and tools from the robot.	

Removal, parallel arm

Use this procedure to remove the parallel arm.

	Action	Note
1	Decide which calibration routine to use, and take actions accordingly prior to beginning the repair procedure.	

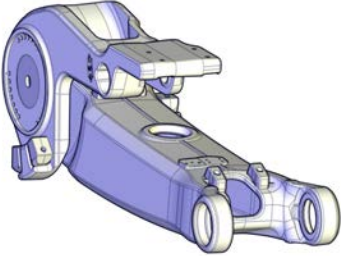
Continues on next page



	Action	Note
2	 DANGER Turn off all: <ul style="list-style-type: none"> • electric power supply • hydraulic pressure supply • air pressure supply to the robot, before entering the robot working area.	
3	Remove the complete lower arm.	See Replacing the complete lower arm on page 219 .
4	Put the complete lower arm on a workbench as shown in the figure.  Tip Removal of the parallel arm is best performed on a workbench.	 xx1000001024
5	Remove the two VK covers.	 xx1000001371

Continues on next page

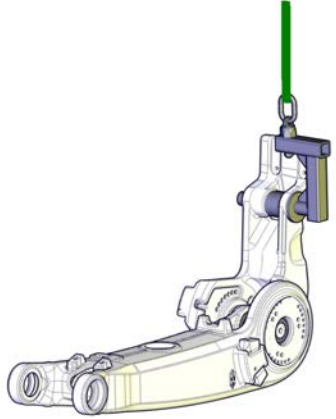

4 Repair

4.4.9 Replacement of parallel arm

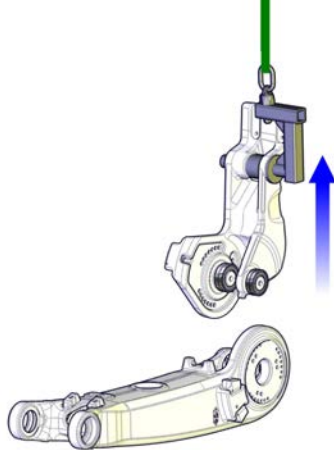
Continued

	Action	Note
6	Fit the <i>lifting accessory, parallel arm</i> on the parallel arm. Lift the parallel arm to the position shown in the figure.	Art. no. is specified in Required equipment on page 227 .  xx1000001375
7	Disassemble the parallel arm from the lower arm by using the <i>pressing tool, lower arm</i> .	Art. no. is specified in Required equipment on page 227 .
8	 CAUTION The parallel arm system weighs 118 kg. All lifting accessories used must be sized accordingly!	
9	Remove the parallel arm.	 xx1000001018

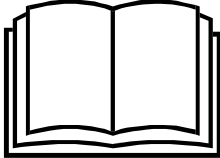
Continues on next page

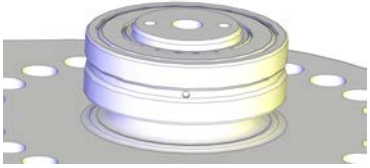
	Action	Note
10	<p>If needed, replace bearings, using the <i>press equipment, parallel arm</i>, according to user instructions enclosed with the equipment.</p>  <p>xx0900000813</p> <p>Go to the user instructions enclosed with the press tool.</p> <p> DANGER</p> <p>Handling the tool incorrectly will cause serious injury. Read and follow enclosed user instructions for the tool.</p>	 <p>xx1100000218</p>

Refitting, parallel arm

Use this procedure to refit the parallel arm.

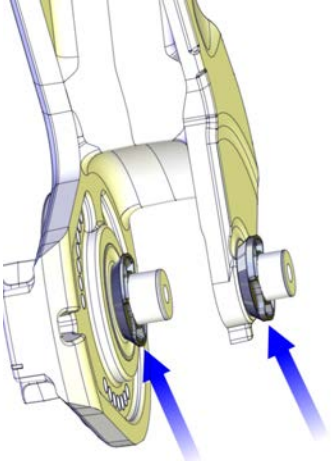



	Action	Note
1	Refitting of the parallel arm is best performed on a workbench.	
2	Check that the assembly and the condition of the <i>bearing</i> is good.	
3	Apply some <i>grease</i> on the shafts on the parallel arm.	Specified in Required equipment on page 227
4	Refit a <i>spacing sleeve</i> on each shaft.	 <p>xx1000001376</p>

Continues on next page

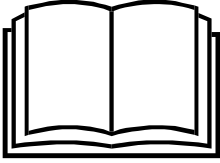

4 Repair

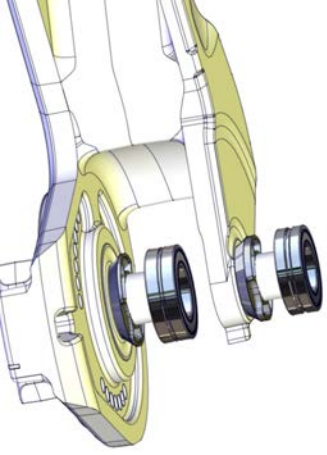
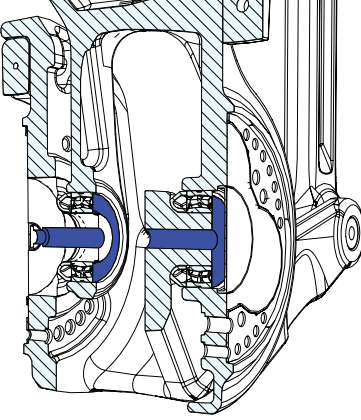
4.4.9 Replacement of parallel arm

Continued

	Action	Note
5	<p>Refit a bearing on each shaft with <i>pressing tool, lower arm</i>.</p>  <p>xx0900000813</p> <p>Go to the user instructions enclosed with the press tool.</p> <p> DANGER</p> <p>Handling the tool incorrectly will cause serious injury. Read and follow enclosed user instructions for the tool.</p>	<p>Art. no. is specified in Required equipment on page 227</p>  <p>xx1000001377</p>
6	<p>Foundry Plus: Apply rust preventive on the highlighted areas.</p>	 <p>xx1400001127</p>
7	<p>Refit the protection washer on the inner shaft.</p>	
8	<p>Refit the lock ring on the inner shaft.</p>	
9	<p> CAUTION</p> <p>The parallel arm system weighs 118 kg. All lifting accessories used must be sized accordingly!</p>	
10	<p>Fit the <i>lifting accessory, parallel arm</i>.</p>	<p>Art. no. is specified in Required equipment on page 227.</p>
11	<p>Lift the parallel arm onto the workbench where the lower arm is placed.</p>	<p>Art. no. is specified in Required equipment on page 227</p>
12	<p>Adjust the lower arm in a way that both holes are parallel. Use a <i>level</i>.</p>	

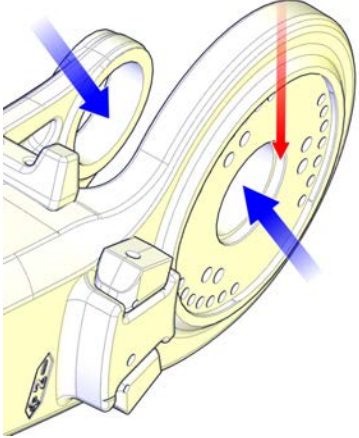
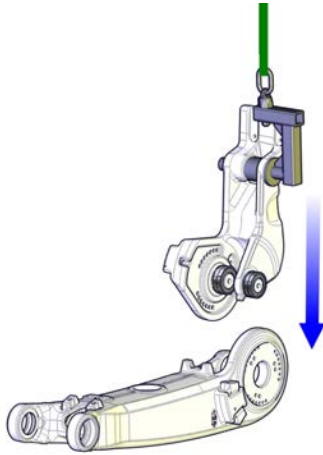
Continues on next page

	Action	Note
13	<p>Apply some <i>grease</i> in the holes in the lower arm (thick blue arrows).</p> <p> Note</p> <p>Do not put grease on the surfaces for the VK covers (thin red arrow)!</p>	 <p>xx1000001380</p>
14	Lift the parallel arm, lower it and put it in mounting position with the lower arm.	 <p>xx1000001379</p>
15	Carefully press the parallel arm onto the lower arm using the <i>pressing tool, lower arm</i> .	Art. no. is specified in Required equipment on page 227 .
16	Fit the big and small VK cover.	
17	Refit the complete lower arm.	Detailed in section Replacing the complete lower arm on page 219 .
18	Recalibrate the robot.	<p>Axis Calibration is described in Calibrating with Axis Calibration method on page 314.</p> <p>General calibration information is included in section Calibration on page 303.</p>
19	<p> DANGER</p> <p>Make sure all safety requirements are met when performing the first test run.</p>	

4 Repair

4.5.1 Replacing the balancing device

4.5 Frame and base

4.5.1 Replacing the balancing device

Location, balancing device

The balancing device is located as shown in the figure.

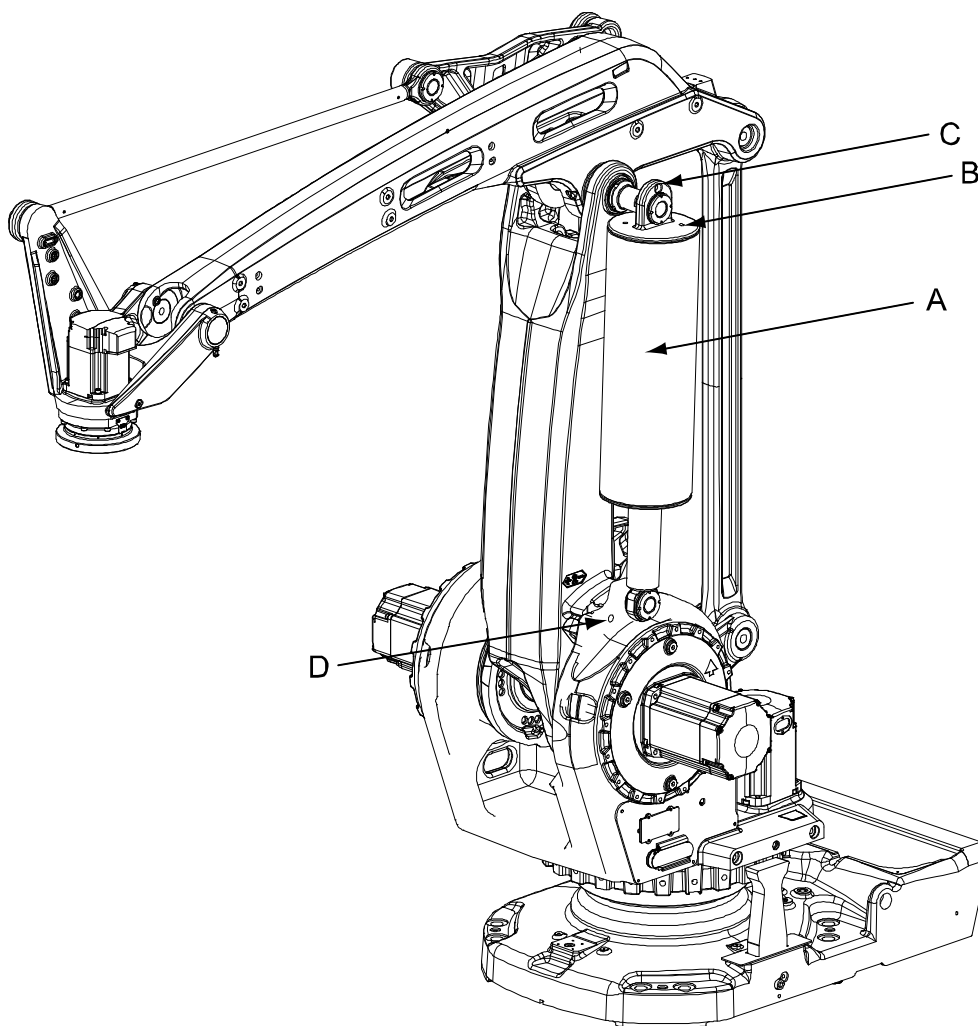

xx0600002604

A	Balancing device
B	Hole to neutralize the spring force. (M12)
C	Hole on lifting ear
D	Hole for lock screw

Required equipment

Equipment, etc.	Art.no.	Note
Balancing device	For spare part number, see Spare part lists on page 351 .	

Continues on next page

Equipment, etc.	Art.no.	Note
Auxiliary shaft	3HAC5281-1	For fitting the inner rings of the bearings
Auxiliary shaft, long	3HAC5275-1	
Auxiliary shaft, short	3HAC5276-1	
Lock screw	-	M16 x 90 For securing the lower arm.
Screw		2 pcs, M12 x 50 For neutralizing the spring force of the balancing cylinder.
Lubrication tool	3HAC5222-2	
Lifting accessories	-	
Locking liquid	3HAB7116-1	Loctite 243
Standard toolkit	-	Content is defined in section Standard tools on page 346 .
Ball bearing puller	-	

Removing, balancing device

Use this procedure to remove the balancing device.

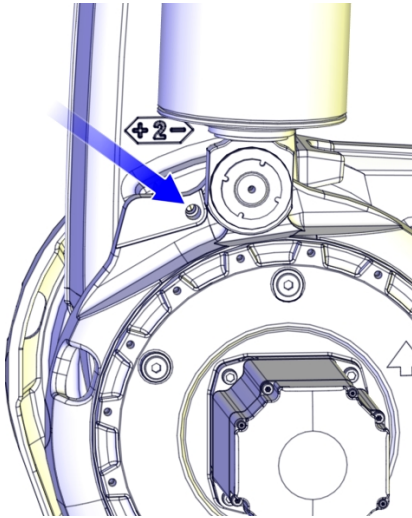
	Action	Note
1	Move the robot to a position close enough to its calibration position, to allow the lock screw to be inserted into the hole for the lock screw.	The balancing device must be placed in a 90° angle from the floor, in order to be lifted in the most secure way. See the figure in Location, balancing device on page 234 .
2	Lock the lower arm by inserting the <i>lock screw</i> into the <i>hole</i> .  CAUTION Tighten by hand!	 xx1000001101

Continues on next page



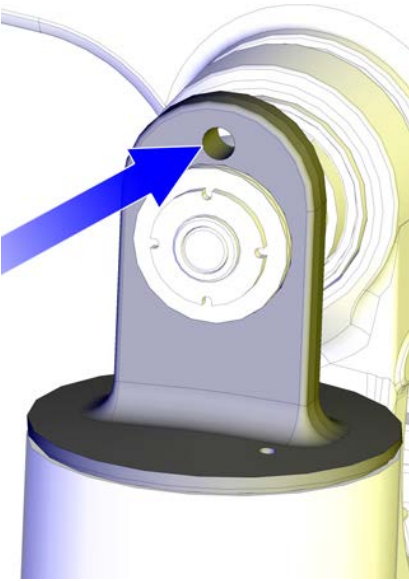

4 Repair

4.5.1 Replacing the balancing device

Continued

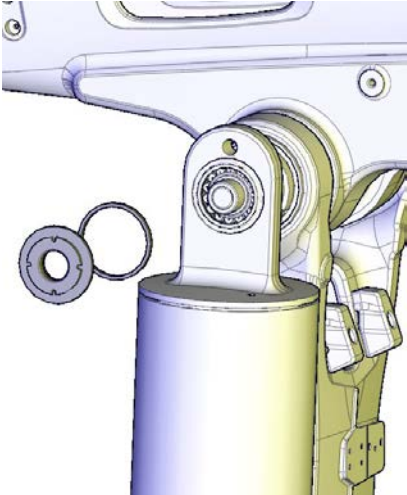
	Action	Note
3	<p> DANGER</p> <p>Turn off all:</p> <ul style="list-style-type: none">• electric power supply• hydraulic pressure supply• air pressure supply <p>to the robot, before entering the robot working area.</p>	
4	Remove the <i>protection hood</i> in the upper end of the balancing device.	
5	<p>Insert two <i>screws, M12x50</i> in the holes to neutralize the spring force. Screw in the screws until they have proper contact with the cylinder inside.</p> <p>The length of the cylinder is now locked and the balancing device is unloaded. It should now be possible to easily rotate the balancing device.</p>	
6	<p>Attach a <i>lifting accessories</i> to the balancing device.</p> <p>Use the <i>hole</i> in the lifting ear.</p>	 <p>xx1000001112</p>

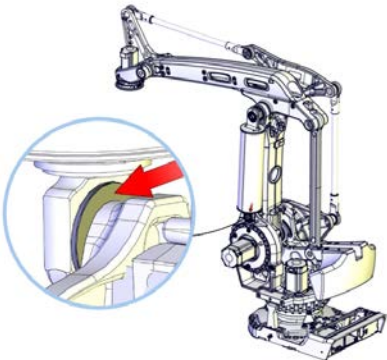
Continues on next page

	Action	Note
7	<p>Remove the upper and lower <i>lock nuts</i> and <i>support washers</i> (2+2 pcs).</p> <p> Note</p> <p>Make sure that the shaft between the upper and lower arm does not rotate when unscrewing the lock nuts! The lock nut is locked with Loctite 243.</p>	 <p>xx1000001113</p>
8	<p>Fit the <i>auxiliary shafts</i> on the upper and lower pivot shaft.</p> <p>Fit the short auxiliary shaft on the upper shaft and the longer on the lower shaft.</p>	<p>Art.no. is specified in Required equipment on page 234</p>
9	<p>Stretch the <i>roundsling</i>.</p>	
10	<p>Apply a <i>ball bearing puller</i> behind the lower ear of the balancing device.</p> <p> Note</p> <p>The ball bearing puller must be applied around the <i>spacer ring</i>. See figure!</p>	 <p>xx1000001115</p>
11	<p> CAUTION</p> <p>The balancing device weighs 70 kg. All lifting accessories used must be sized accordingly!</p>	

Continues on next page

4 Repair

4.5.1 Replacing the balancing device

Continued

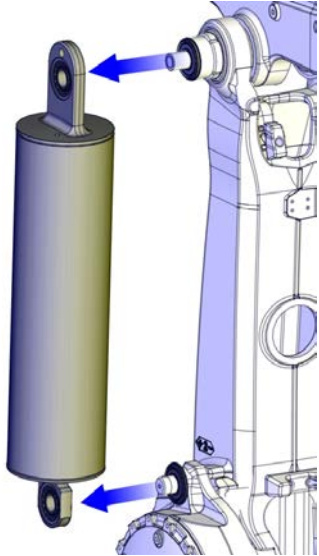
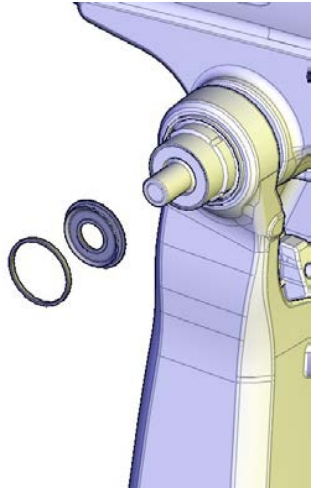

	Action	Note
12	With the help of the ball bearing puller carefully remove the <i>balancing device</i> from its upper and lower attachments.	 <p data-bbox="991 869 1102 891">xx1000001114</p>
13	Remove the balancing device and put it in a safe place.	
14	Remove the inner rings of the bearings.	
15	Remove upper and lower <i>spacer rings</i> and <i>support washers</i> (2+2 pcs).	 <p data-bbox="991 1529 1102 1552">xx1000001116</p>
16	Remove residual grease.	

Refitting, balancing device

use this procedure to refit the balancing device.

	Action	Note
1	Check the bearings. Replace if needed.	

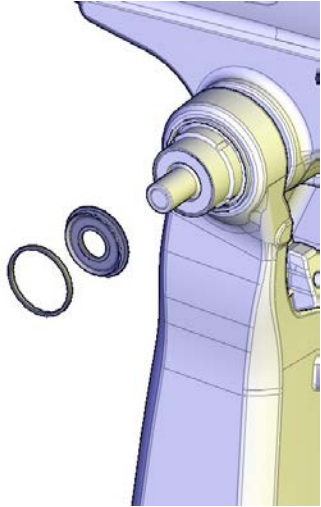
Continues on next page

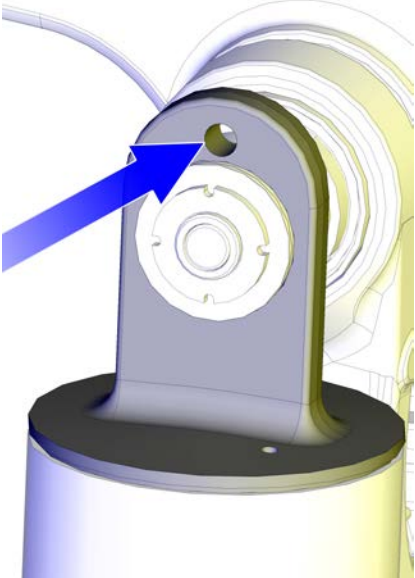
	Action	Note
2	Refit the inner <i>sealing rings</i> and <i>support washers</i> in both ends.	 <p>xx1000001116</p>
3	Refit the inner ring of the bearings on the upper and lower pivot shaft with the auxiliary shaft.	
4	Fit the auxiliary shafts on the upper and lower shafts. Fit the short auxiliary shaft on the upper shaft and the longer on the lower shaft.	Art.no. is specified in section Required equipment on page 234
5	 CAUTION The balancing device weighs 70 kg. All lifting accessories used must be sized accordingly!	
6	Attach lifting accessory to the balancing device and lift it on to the auxiliary shafts.	 <p>xx1000001112</p>

Continues on next page



4 Repair

4.5.1 Replacing the balancing device

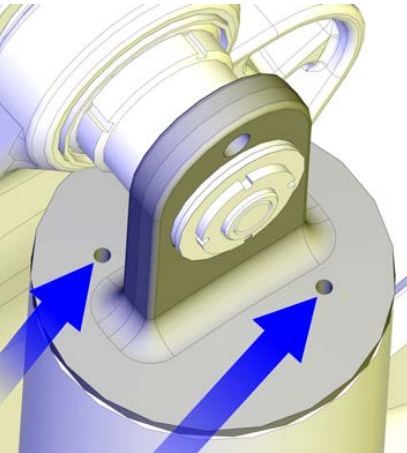
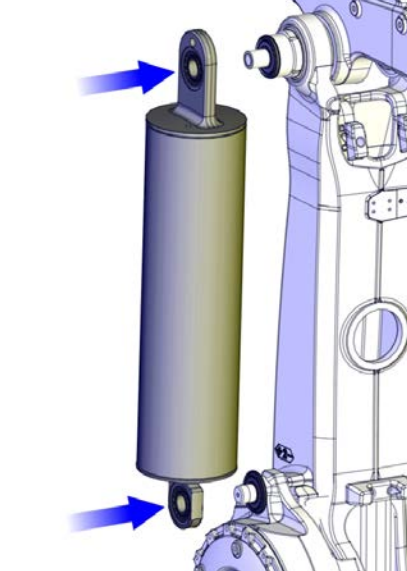
Continued

	Action	Note
7	<p>Adjust the length between the upper and lower bearings by means of the M12 screws, used to neutralize the spring force.</p> <p>This length should preferably be 0.5 mm too short than 0.1 mm too long. If the distance is too long the bearings may be damaged when erecting the balancing device.</p>	 <p>xx1000001111</p>
8	<p>Carefully refit the balancing device on the upper and lower shafts.</p>	 <p>xx1000001271</p>
9	<p>Fit the <i>lubricating tool</i>. The tool should be tightened to the bottom position by hand power only.</p>	<p>Art. no. is specified in section Required equipment on page 234.</p>
10	<p>Fill the bearings with grease through the nipple. Continue until grease exudes behind the inner sealing.</p>	
11	<p>Remove the lubricating tool and wipe off protruding grease.</p>	
12	<p>Remove the auxiliary shafts.</p>	
13	<p>Apply <i>locking liquid</i> on the threads of the lock nuts.</p>	<p>Specified in section Required equipment on page 234.</p>

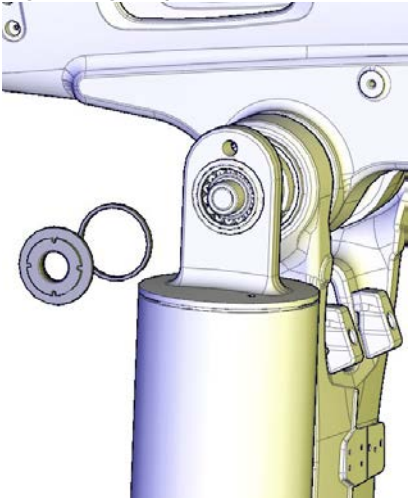
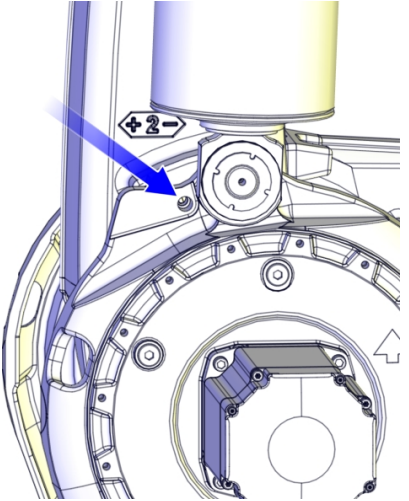
Continues on next page

	Action	Note
14	Refit the lock nuts and support washers.	<p>Tightening torque: 120 Nm</p>  <p>xx1000001113</p>
15	Check play (min. 0.1 mm) between support washers and bearing seat at both bearings.	
16	Remove the M12x50 screws from the balancing device to restore the springforce.	
17	Remove the <i>lock screw</i> .	 <p>xx1000001101</p>
18	 <p>DANGER</p> <p>Make sure all safety requirements are met when performing the first test run.</p>	

4 Repair

4.5.2 Replacing the SMB unit

4.5.2 Replacing the SMB unit

Location of SMB unit

The SMB unit (SMB = serial measurement board) is located on the left hand side of the frame as shown in the figure.

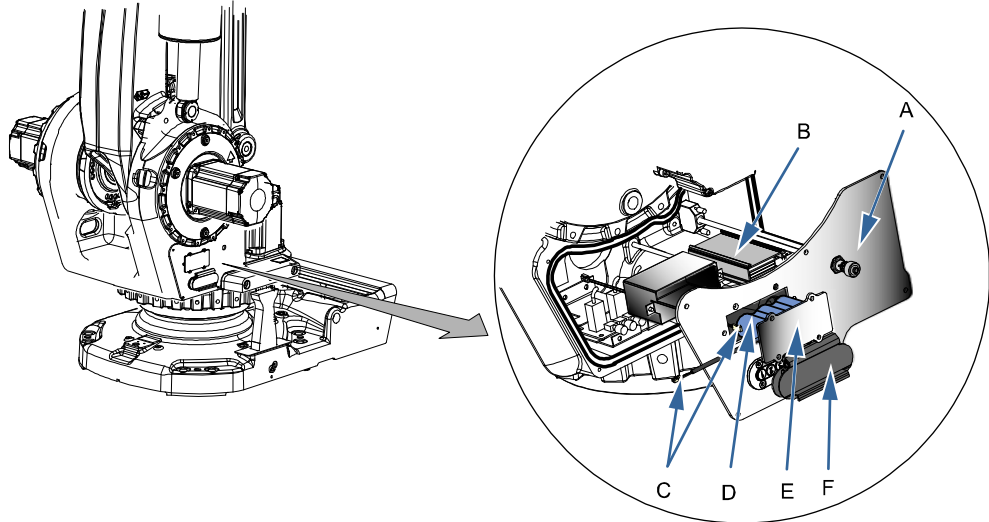

xx0600002621

A	SMB cover
B	SMB unit
C	Battery cable
D	SMB battery
E	SMB battery, cover

Required equipment



Note

There are different variants of SMB units and batteries. The variant with the 3-pole battery contact has longer lifetime for the battery.

It is important that the SMB unit uses the correct battery. Make sure to order the correct spare parts. Do not replace the battery contact!



Equipment, etc.	Article number	Note
SMB unit	For spare part number, see: Spare part lists on page 351 .	
Battery pack	For spare part number, see: Spare part lists on page 351 .	
Standard toolkit	-	Content is defined in section Standard tools on page 346 .

Continues on next page

Equipment, etc.	Article number	Note
Circuit diagram	-	See chapter Circuit diagrams on page 353 .

Removing, SMB unit

Use this procedure to remove the SMB unit.

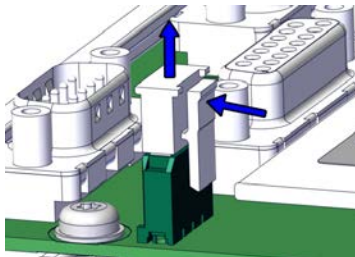
	Action	Note
1	Move the robot to the calibration position.	
2	 DANGER Turn off all: <ul style="list-style-type: none"> • electric power supply • hydraulic pressure supply • air pressure supply to the robot, before entering the robot working area.	
3	 ELECTROSTATIC DISCHARGE (ESD) The unit is sensitive to ESD. Before handling the unit read the safety information in section The unit is sensitive to ESD on page 49 .	
4	Remove the SMB cover by unscrewing its attachment screws.  CAUTION Clean cover from metal residues before opening. Metal residues can cause shortage on the boards which can result in hazardous failures.	Shown in the figure Location of SMB unit on page 242 .
5	Use caution and remove the connectors X8, X9 and X10 from the brake release board, if need of more space.	
6	Remove the nuts and washers from the guide pins that secure the board.	Shown in the figure Location of SMB unit on page 242 .
7	Use caution and disconnect the connectors from the SMB unit when pulling the board out.	Connectors R1.SMB1-3, R1.SMB4-6 and R2.SMB
8	Disconnect the battery cable by pressing down the upper lip of the R2.G connector to release the lock while pulling the connector upwards.	 xx170000993

Continues on next page





4 Repair

4.5.2 Replacing the SMB unit

Continued

Refitting, SMB unit

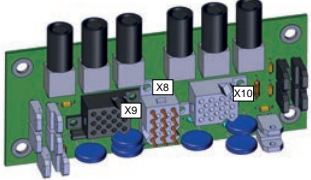
Use this procedure to refit the SMB unit.

	Action	Note
1	 <p>DANGER</p> <p>Turn off all:</p> <ul style="list-style-type: none"> • electric power supply • hydraulic pressure supply • air pressure supply <p>to the robot, before entering the robot working area.</p>	
2	 <p>ELECTROSTATIC DISCHARGE (ESD)</p> <p>The unit is sensitive to ESD. Before handling the unit read the safety information in section The unit is sensitive to ESD on page 49.</p>	
3	<p>Connect the <i>battery cable</i> to the SMB unit. Make sure the lock on the battery cable connector R2.G snaps into place during refitting.</p>	<p>Shown in the figure Location of SMB unit on page 242.</p>
4	<p>Connect all connectors to the SMB board: R1.SMB1-3, R1.SMB6 and R2.SMB</p>	<p>Art. no. is specified in Required equipment on page 242.</p> <p>Shown in the figure Location of SMB unit on page 242.</p>
5	<p>Fit the <i>SMB unit</i> onto the <i>guide pins</i>.</p>	
6	<p>Secure the SMB unit to the pins with the nuts and washers.</p>	
7	<p>If disconnected, reconnect the connectors X8, X9 and X10 to the brake release board. Be careful not to damage the sockets or pins. Make sure the connector and its locking arms are snapped down properly.</p>	 <p>xx1700000978</p>
8	<p>Secure the <i>SMB cover</i> with its attachment screws. If cabling is used for 7th axis (option), refit the 7th axis connector to the SMB cover and tighten with 6 Nm.</p>	<p>Shown in the figure Location of SMB unit on page 242.</p>
9	<p>Update the revolution counters.</p>	<p>See Updating revolution counters on IRC5 robots on page 308.</p>
10	 <p>DANGER</p> <p>Make sure all safety requirements are met when performing the first test run.</p>	

4.5.3 Replacing the brake release board

Location of brake release board

The brake release unit is located together with the SMB unit on the left hand side of the frame, right next to the gearbox, axis 2, as shown in figure below.

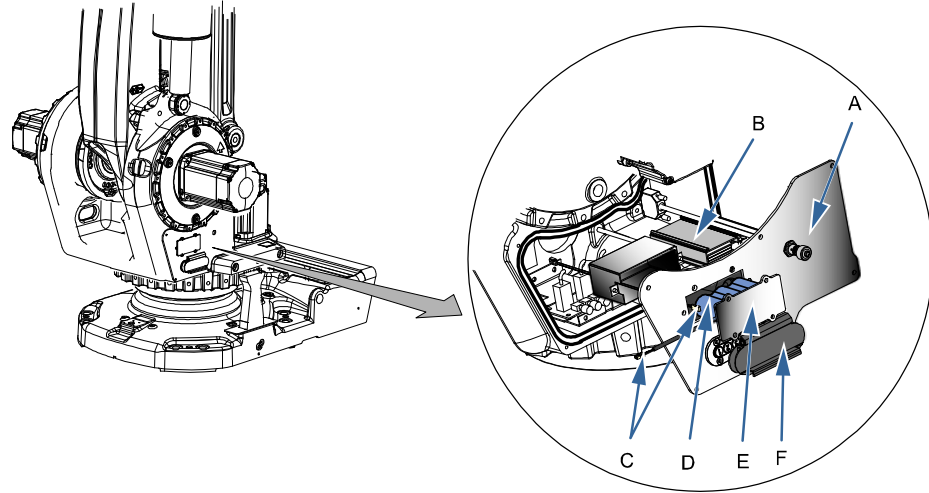

xx0600002621

A	SMB cover
B	SMB unit
C	Battery cable
D	SMB battery
E	SMB battery, cover

Required equipment

Equipment, etc.	Article number	Note
Brake release board	3HAC065020-001	DSQC1050
Standard toolkit	-	Content is defined in section Standard tools on page 346 .
Other tools and procedures may be required. See references to these procedures in the step-by-step instructions below.		These procedures include references to the tools required.

Continues on next page



4 Repair

4.5.3 Replacing the brake release board

Continued

Removing, brake release board

Use this procedure to remove the brake release board.

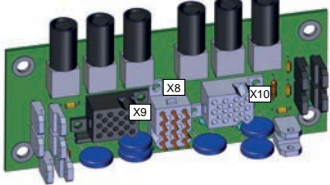

	Action	Note
1	 DANGER Turn off all: <ul style="list-style-type: none"> • electric power supply to the robot • hydraulic pressure supply to the robot • air pressure supply to the robot Before entering the robot working area.	
2	 ELECTROSTATIC DISCHARGE (ESD) The unit is sensitive to ESD. Before handling the unit read the safety information in section The unit is sensitive to ESD on page 49 .	
3	Remove the push button guard from the SMB cover.	Shown in the figure Location of brake release board on page 245 . The guard must be removed to ensure a correct refitting of the brake release board.
4	Open the SMB cover by unscrewing the attachment screws. Let the battery stay connected, to avoid the need of synchronization of the robot!  CAUTION Clean cover from metal residues before opening. Metal residues can cause shortage on the boards which can result in hazardous failures.	Shown in the figure Location of brake release board on page 245 .
5	Take a picture or make notes of how the robot cabling is positioned in regard to the brake release board.	
6	Remove the complete brake release board (including brake release board and bracket) from the SMB recess, by removing its two attachment screws.	
7	Disconnect the connectors X8, X9 and X10 from the brake release board.	 <p>xx1700000978</p> Location of the brake release unit is shown in the figure Location of brake release board on page 245 .

Continues on next page

	Action	Note
8	Remove the brake release board from the bracket by removing the four attachment screws.	

Refitting, brake release board

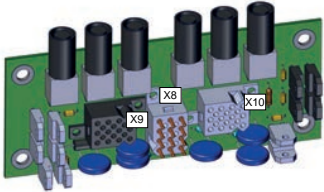
Use this procedure to refit the brake release board.

	Action	Note
1	 ELECTROSTATIC DISCHARGE (ESD) The unit is sensitive to ESD. Before handling the unit read the safety information in section The unit is sensitive to ESD on page 49 .	
2	Connect the connectors X8, X9 and X10 to the brake release board. Be careful not to damage the sockets or pins. Make sure the connector and its locking arms are snapped down properly.	 xx1700000978
3	Fasten the <i>brake release board</i> on the bracket with the attachment screws. Make sure the board is positioned as straight as possible on the bracket! The push buttons can otherwise get jammed when the SMB cover is refitted.	Maximum tightening torque: 5 Nm. Shown in the figure Location of brake release board on page 245 . Art. no. is specified in Required equipment on page 245 .
4	Refit the complete brake release board (including brake release board and bracket) to the SMB recess with the two attachment screws.	
5	Verify that the robot cabling is positioned correctly, according to previously taken picture/notes.  WARNING Screened cables must not get in contact with the brake release board after installation. Eliminate all risks of contact between screened cables and the brake release board.	
6	Refit the <i>SMB cover</i> with its attachment screws.	Shown in the figure Location of brake release board on page 245 .
7	 WARNING Before continuing any service work, follow the safety procedure in The brake release buttons may be jammed after service work on page 147 .	
8	Refit the <i>push button guard</i> to the SMB cover.	Shown in the figure Location of brake release board on page 245 .

Continues on next page

4 Repair

4.5.3 Replacing the brake release board

Continued

	Action	Note
9	Press the push buttons 1 to 6, one at a time, to make sure that the buttons are moving freely and do not stay in a locked position.	
10	If the battery has been disconnected the revolution counter must be updated.	Detailed in the Calibration chapter - section Updating revolution counters on IRC5 robots on page 308 .
11	 DANGER Make sure all safety requirements are met when performing the first test run.	

4.6 Motors

4.6.1 Replacing motor, axis 1

Location of motor axis 1

The motor axis 1 is located on the left hand side of the robot as shown in the figure.

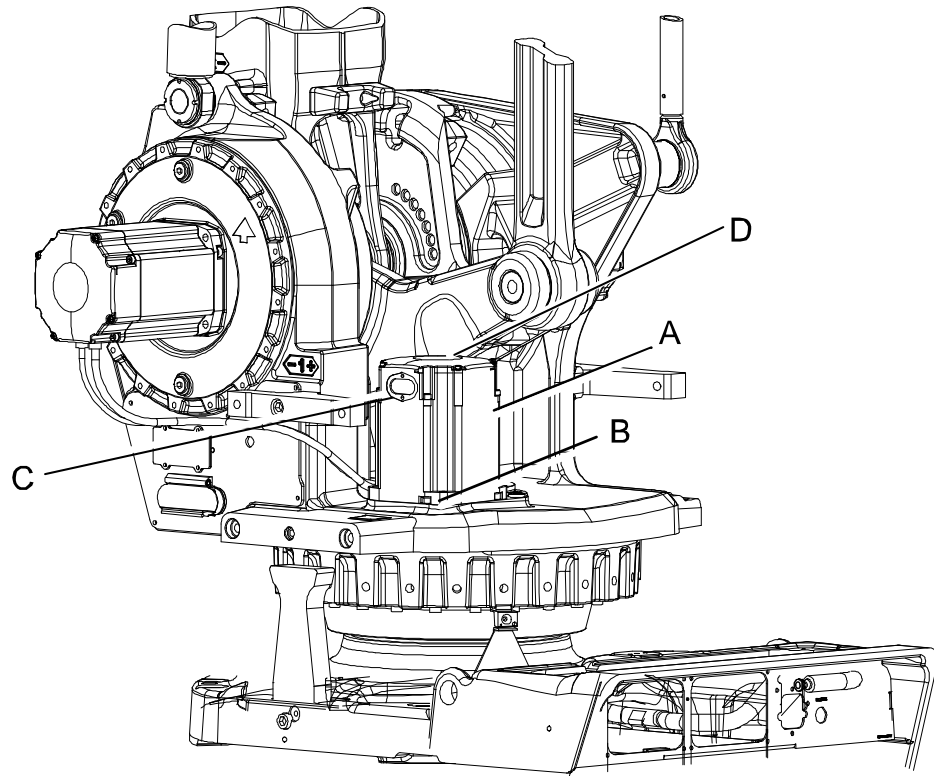

xx0600002598

A	Motor axis 1
B	Motor attachment screws and washers
C	Cable gland cover (located on the left hand side of the motor)
D	Motor cover

Required equipment

Equipment, etc	Art.no.	Note
Motor axis 1	For spare part number, see: <ul style="list-style-type: none"> Spare part lists on page 351 	Includes: <ul style="list-style-type: none"> motor pinion o-ring (The old o-ring must be replaced when replacing the motor)
Grease	3HAC042536-001	Shell Gadus S2 For lubricating the o-ring.
Bits extension	3HAC12342-1	Used to reach the attachment screws for the motor.

Continues on next page

4 Repair

4.6.1 Replacing motor, axis 1

Continued

Equipment, etc	Art.no.	Note
Power supply	-	24 VDC, max. 1,5 A For releasing the brakes.
Standard toolkit	-	Content is defined in section Standard tools on page 346 .
Other tools and procedures may be required. See references to these procedures in the step-by-step instructions below.		These procedures include references to the tools required.
Circuit diagram		See chapter Circuit diagrams on page 353 .

Deciding calibration routine

Decide which calibration routine to be used, based on the information in the table. Depending on which routine is chosen, action might be required prior to beginning the repair work of the robot, see the table.



	Action	Note
1	Decide which calibration routine to use for calibrating the robot. <ul style="list-style-type: none">Reference calibration. External cable packages (DressPack) and tools can stay fitted on the robot.Fine calibration. All external cable packages (DressPack) and tools must be removed from the robot.	
	If the robot is to be calibrated with reference calibration: Find previous reference values for the axis or create new reference values. These values are to be used after the repair procedure is completed, for calibration of the robot. If no previous reference values exist, and no new reference values can be created, then reference calibration is not possible.	Follow the instructions given in the reference calibration routine on the FlexPendant to create reference values. Creating new values requires possibility to move the robot. Read more about reference calibration for Axis Calibration in <i>Product manual - IRB 4600</i> .
	If the robot is to be calibrated with fine calibration: Remove all external cable packages (DressPack) and tools from the robot.	

Removing motor axis 1

Use this procedure to remove motor axis 1.

	Action	Note
1	Decide which calibration routine to use, and take actions accordingly prior to beginning the repair procedure.	

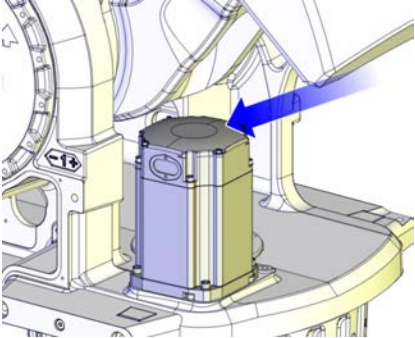
Continues on next page

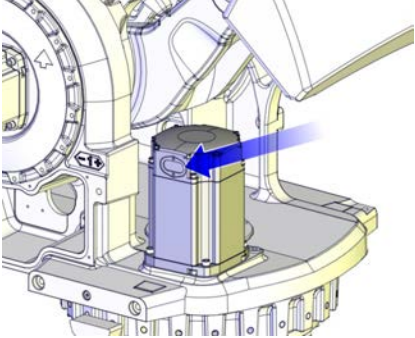
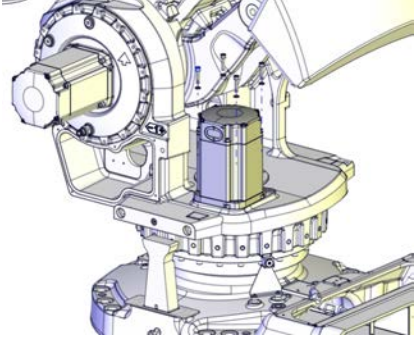

	Action	Note
2	<p> DANGER</p> <p>Turn off all:</p> <ul style="list-style-type: none"> • electric power supply • hydraulic pressure supply • air pressure supply <p>to the robot, before entering the robot working area.</p>	
3	<p>Remove the <i>motor cover</i> to get access to the connectors on top of the motor.</p>	 <p>xx1000001092</p>
4	<p>Remove the <i>cable gland cover</i> at the cable exit of the motor.</p> <p> Note</p> <p>Make sure the gasket is undamaged! Replace if damaged.</p>	 <p>xx1000001094</p>
5	<p>Disconnect all connectors beneath the motor cover.</p>	
6	<p>In order to release the brake, connect the 24 VDC power supply.</p>	<p>Connect to connector R2.MP1</p> <ul style="list-style-type: none"> • + : pin 2 • - : pin 5
7	<p>Remove the <i>attachment screws</i> of the motor. Use the bits extension.</p>	 <p>xx1000001090</p>

Continues on next page

4 Repair

4.6.1 Replacing motor, axis 1

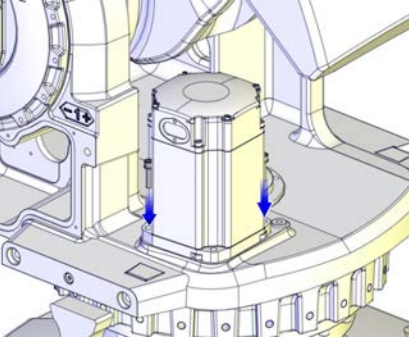

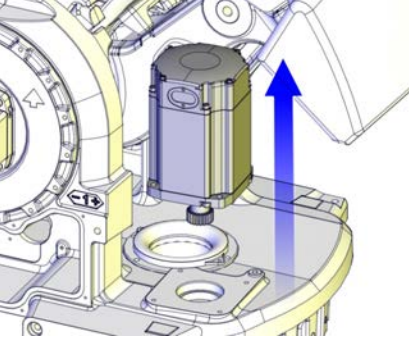

Continued

	Action	Note
8	If required, press the motor out of position by fitting two screws in the holes on the motor for pressing out the motor.	Always use removal screws and tools in pairs!  xx1000001207
9	 CAUTION The motor weighs 29 kg. All lifting accessories used must be sized accordingly!	
10	Remove the motor by carefully lifting it straight up to get the pinion away from gear.  CAUTION Be careful not to damage the pinion in the process!	 xx1000001021
11	Disconnect the brake release voltage.	
12	Check the pinion. If there is any damage, the pinion must be replaced.	

Continues on next page

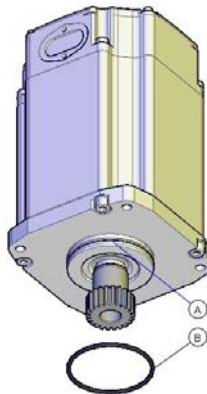
Refitting motor axis 1

Use this procedure to refit motor axis 1.

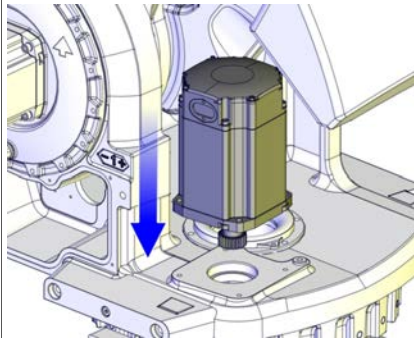



	Action	Note
1	<p>Make sure the <i>o-ring</i> on the <i>circumference</i> of the motor is seated properly. Lightly lubricate the o-ring with <i>grease</i>.</p>	 <p>xx1000001096</p> <p>Parts: A Circumference of motor B O-ring</p> <p> Note The o-ring must be replaced when replacing the motor.</p>
2	<p> CAUTION</p> <p>The motor weighs 29 kg. All lifting accessories used must be sized accordingly!</p>	
3	<p>In order to release the brake, connect the 24 VDC power supply.</p>	<p>Connect to connector R2.MP1</p> <ul style="list-style-type: none"> • + : pin 2 • - : pin 5
4	<p>Gently lower the <i>motor</i> into the gear, making sure the <i>pinion</i> is properly mated to the gearbox of axis 1.</p> <p> Note Make sure the motor is turned the right way. See figure.</p> <p> Note Make sure the motor pinion does not get damaged!</p>	 <p>xx1000001269</p>

Continues on next page

4 Repair

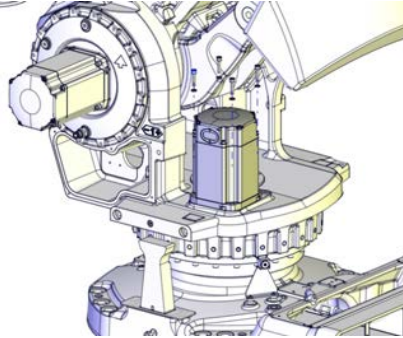
4.6.1 Replacing motor, axis 1

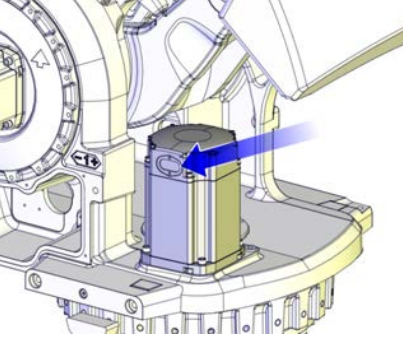
Continued

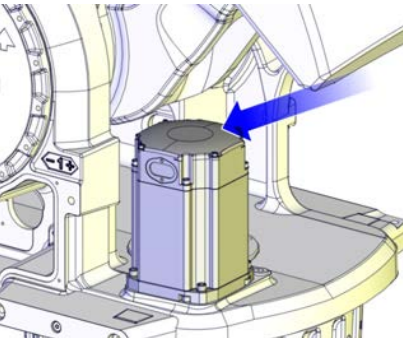
	Action	Note
5	Secure the motor with its four <i>attachment screws</i> and plain <i>washers</i> . Use the bits extension.	 <p>xx1000001090</p> <p>Attachment screws:</p> <ul style="list-style-type: none"> • M10x40 quality 12.9 Gleitmo <p>Tightening torque:</p> <ul style="list-style-type: none"> • 50 Nm
6	Disconnect the brake release voltage.	
7	Reconnect all connectors beneath the motor cover.	
8	Refit the <i>cable gland cover</i> at the cable exit with its attachment screws.  Note Make sure the cover is tightly sealed! Replace gasket if damaged.	 <p>xx1000001094</p>
9	Refit the <i>motor cover</i> with its attachment screws.  Note Make sure the cover is tightly sealed!	 <p>xx1000001092</p>
10	Recalibrate the robot!	<p>Axis Calibration is described in Calibrating with Axis Calibration method on page 314.</p> <p>General calibration information is included in section Calibration on page 303.</p>

Continues on next page

	Action	Note
11	 DANGER Make sure all safety requirements are met when performing the first test run.	

4 Repair

4.6.2 Replacing motors, axes 2 and 3

4.6.2 Replacing motors, axes 2 and 3

Location of motors, axes 2 and 3

The motors axes 2 and 3 are located on either side of the robot as shown in the figure.

The procedure is the same for both motors.

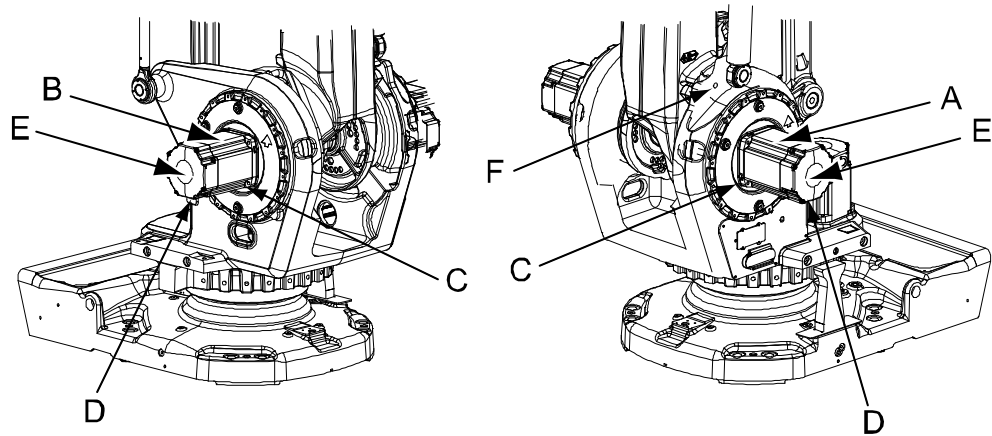

xx0600002599

A	Motor, axis 2
B	Motor, axis 3
C	Motor attachment screws and washers
D	Cable gland cover (located on the lower side of the motor)
E	Motor cover
F	Hole for lock screw

Required equipment

Equipment, etc.	Art. no.	Note
Motor axes 2-3	For spare part no. see: <ul style="list-style-type: none">• Spare part lists on page 351 chapter	Includes <ul style="list-style-type: none">• motor• pinion• o-ring (the o-ring must be replaced when the motor is replaced)
Grease	3HAC042536-001	Shell Gadus S2 For lubricating the o-ring.
Guide pins	3HAC13120-2	M10x150 For guiding the motor. Guide pins are to be used in pairs!
Lifting accessory, motor axes 2-3	3HAC15534-1	
Lock screw	-	M16x90 For securing the lower arm.
Bits extension	3HAC12342-1	Used to reach the attachment screws for the motor.

Continues on next page

Equipment, etc.	Art. no.	Note
Power supply	-	24 VDC, 1.5 A For releasing the brakes.
Rotation tool		Used to rotate the motor pinion when mating it to the gear, when brakes are released with 24 VDC power supply.
Standard toolkit		Content is defined in section Standard tools on page 346 .
Other tools and procedures may be required. See references to these procedures in the step-by-step instructions below.		These procedures include references to the tools required.
Circuit diagram		See chapter Circuit diagrams on page 353 .

Deciding calibration routine

Decide which calibration routine to be used, based on the information in the table. Depending on which routine is chosen, action might be required prior to beginning the repair work of the robot, see the table.

	Action	Note
1	Decide which calibration routine to use for calibrating the robot. <ul style="list-style-type: none"> Reference calibration. External cable packages (DressPack) and tools can stay fitted on the robot. Fine calibration. All external cable packages (DressPack) and tools must be removed from the robot. 	
	<p>If the robot is to be calibrated with reference calibration:</p> <p>Find previous reference values for the axis or create new reference values. These values are to be used after the repair procedure is completed, for calibration of the robot.</p> <p>If no previous reference values exist, and no new reference values can be created, then reference calibration is not possible.</p>	<p>Follow the instructions given in the reference calibration routine on the FlexPendant to create reference values.</p> <p>Creating new values requires possibility to move the robot.</p> <p>Read more about reference calibration for Axis Calibration in <i>Product manual - IRB 4600</i>.</p>
	<p>If the robot is to be calibrated with fine calibration:</p> <p>Remove all external cable packages (DressPack) and tools from the robot.</p>	

Removing motors axes 2 and 3

Use this procedure to remove motors axes 2 and 3.

The procedure is the same for both motors.



	Action	Note
1	Decide which calibration routine to use, and take actions accordingly prior to beginning the repair procedure.	

Continues on next page

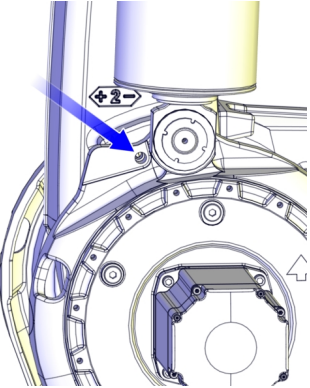

4 Repair

4.6.2 Replacing motors, axes 2 and 3

Continued

	Action	Note
2	<p>Run the robot to a position close enough to its calibration position, to allow the lock screw to be inserted into the <i>hole for lock screw</i>.</p>	 <p>xx1000001101</p>
3	<p>Lock the <i>lower arm</i> by inserting the <i>lock screw</i> into the hole of the frame.</p> <p>This is done in order to secure axis 2 from collapsing when the axis 2 motor is being removed.</p> <p> CAUTION</p> <p>Tighten by hand!</p>	<p>See figure above.</p>
4	<p>Run axis 3 to the end position so that it rests against the mechanical stop. Release the brake of axis 3 in order to set the weight of axis 3 against the mechanical stop.</p> <p>This is done in order to secure axis 3 from collapsing when the axis 3 motor is being removed.</p>	
5	<p> DANGER</p> <p>Turn off all:</p> <ul style="list-style-type: none"> • electric power supply • hydraulic pressure supply • air pressure supply <p>to the robot, before entering the robot working area.</p>	
6	<p>Drain the oil from <i>gearbox</i>.</p>	<p>See section</p> <ul style="list-style-type: none"> • Changing oil, gearbox axes 2 and 3 on page 124.

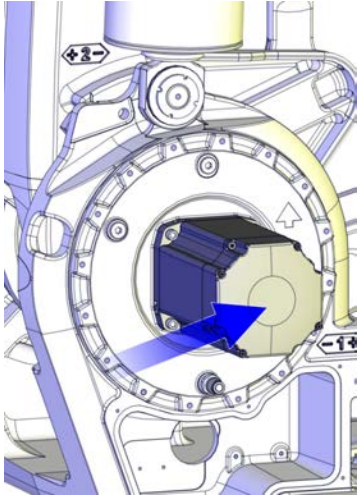
Continues on next page

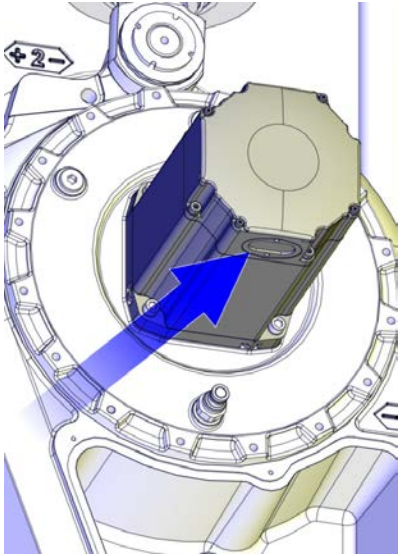
	Action	Note
7	Remove the <i>motor cover</i> .	 <p>xx1000001102</p>
8	Remove the <i>cable gland cover</i> at the cable exit .  Note Make sure the gasket is not damaged! Replace if damaged.	 <p>xx1000001103</p>
9	Disconnect all connectors beneath the motor cover.	
10	In order to release the brake, connect the 24 VDC power supply.	Connect to connector R2.MP2 <ul style="list-style-type: none"> • + : pin 2 • - : pin 5

Continues on next page



4 Repair

4.6.2 Replacing motors, axes 2 and 3

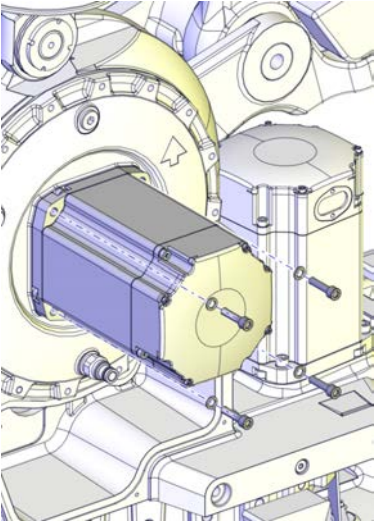
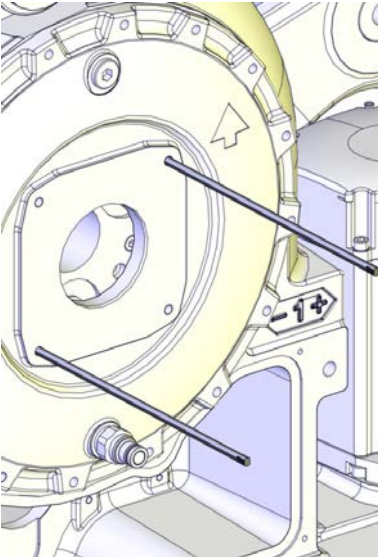
Continued

	Action	Note
11	Unscrew <i>attachment screws</i> and <i>washers</i> of the motor. Use the <i>bits extension</i> .	 xx1000001104
12	Fit two <i>guide pins</i> in two of the motors attachment holes.	Art. no. is specified in Required equipment on page 256 .  xx1000001131

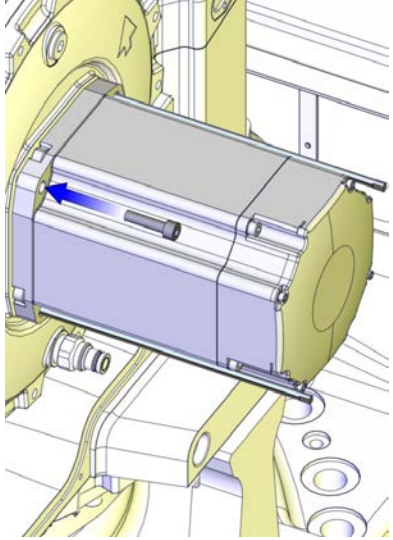
Continues on next page

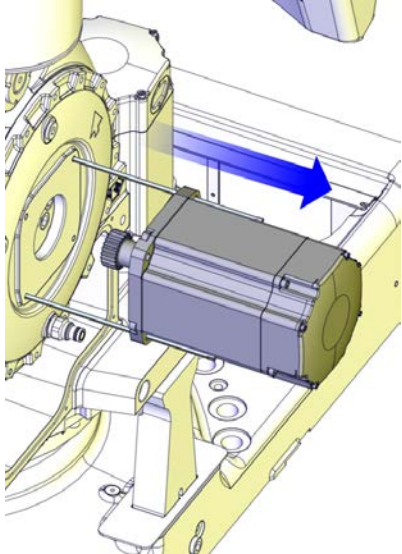
	Action	Note
13	If required, press the motor out of position by fitting two screws in the remaining attachment holes of the motor, diagonal to each other.	<p>M12x70, fully threaded. Always use the removal screws and tools in pairs!</p>  <p>xx1000001184</p>
14	Remove the two screws and fit the <i>lifting tool</i> , motor axes 2-3 to the motor.	Art. no. is specified in Required equipment on page 256 .
15	<p> CAUTION</p> <p>The motor weighs 32 kg. All lifting accessories used must be sized accordingly!</p>	
16	Pull out the <i>motor</i> on the guide pins to get the pinion away from the gear. Make sure the pinion does not get damaged!	<p>The figure shows IRB 760 but the principle is the same.</p>  <p>xx1000001105</p>
17	Remove the motor by gently lifting it straight out and place it on a secure surface.	

Continues on next page

4 Repair

4.6.2 Replacing motors, axes 2 and 3

Continued

	Action	Note
18	Disconnect the brake release voltage!	
19	Check the pinion. If there is any damage, the motor pinion must be replaced.	



Refitting, motors axes 2 and 3

Use this procedure to refit motors axes 2 and 3.

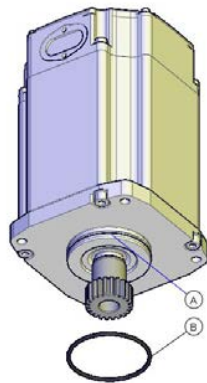
The procedure is the same for both motors.

	Action	Note
1	Make sure the <i>o-ring</i> on the <i>circumference</i> of the motor is seated properly. Lightly lubricate the o-ring with grease.	 <p>xx1000001096</p> <p>Parts:</p> <ul style="list-style-type: none"> A Circumference B O-ring
2	In order to release the brake, connect the 24 VDC power supply.	Connect to connector R2.MP1 <ul style="list-style-type: none"> • + : pin 2 • -: pin 5
3	Fit the <i>lifting tool, motor axes 2-3</i> to the motor.	Art. no. is specified in Required equipment on page 256 .

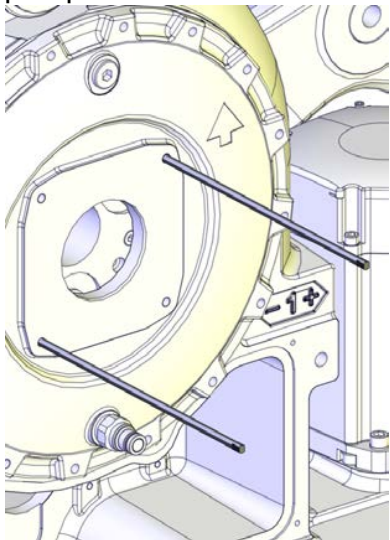
Continues on next page

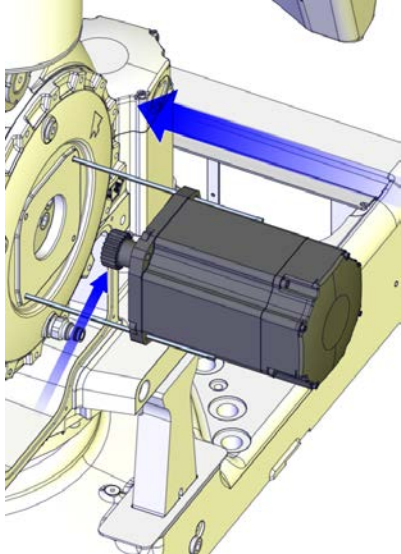
	Action	Note
4	Fit the two <i>guide pins</i> in the two lower motor attachment holes.	<p>Art. no. is specified in Required equipment on page 256.</p> <p>The figure shows IRB 760 but the principle is the same.</p>  <p>xx1000001131</p>
5	<p> CAUTION</p> <p>The motor weighs 32 kg. All lifting accessories used must be sized accordingly!</p>	
6	<p>Lift the <i>motor</i> and guide it on to the <i>guide pins</i>, as close to the correct position as possible without pushing the motor <i>pinion</i> into the gear.</p> <p> Note</p> <p>Make sure the motor is turned the right way, that is connections for the cables facing downwards.</p>	<p>The figure shows IRB 760 but the principle is the same.</p>  <p>xx1000001185</p>
7	Remove the lifting tool and allow the motor to rest on the guide pins.	

Continues on next page



4 Repair

4.6.2 Replacing motors, axes 2 and 3

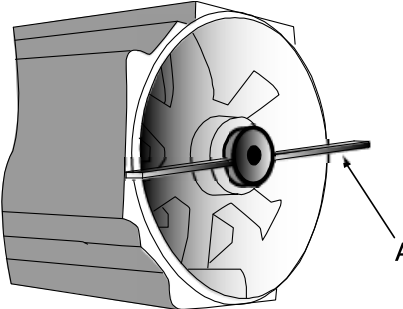
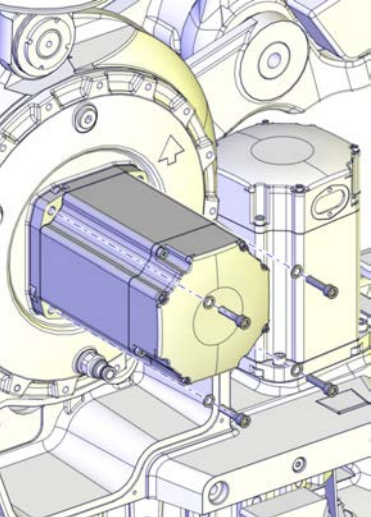
Continued

	Action	Note
8	<p>Use the <i>rotation tool</i> in order to rotate the motor pinion when mating it to the gear (see figure). Fit the motor, making sure the motor pinion is properly mated to the gear of gearbox axis 2-3 and that it doesn't get damaged.</p> <p> Note</p> <p>The rotation tool is used beneath the motor cover, directly on the motor shaft as shown in figure above.</p>	 <p>xx0200000165</p> <p>Part: Rotation tool</p>
9	Remove the guide pins.	
10	<p>Secure the motor with its four <i>attachment screws</i> and <i>plain washers</i>. Use the <i>bits extension</i>.</p> <p>Reused screws can be used, providing they are lubricated as detailed in section Screw joints on page 342 before fitting.</p>	 <p>xx1000001104</p> <p>Attachment screws:</p> <ul style="list-style-type: none"> • M10 x 40 quality 12.9 Gleitmo <p>Tightening torque:</p> <ul style="list-style-type: none"> • 50 Nm
11	Disconnect the brake release voltage.	
12	Reconnect all connectors beneath the motor cover.	Connect in accordance with markings on connectors.

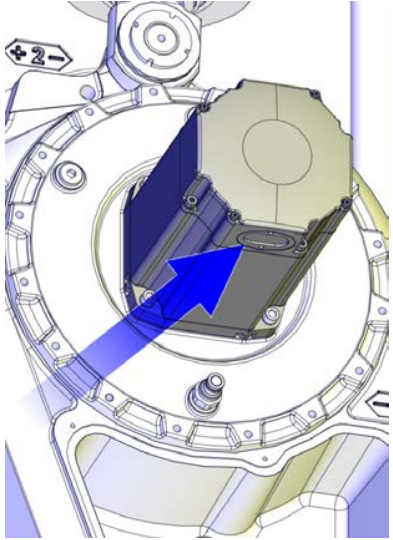
Continues on next page

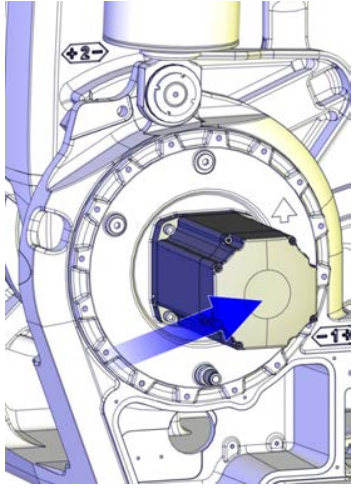
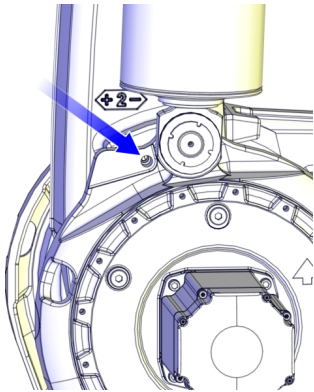
	Action	Note
13	<p>Refit the <i>cable gland cover</i> at the cable exit with its two attachment screws.</p> <p> Note Use a new gasket!</p>	 <p>xx1000001103</p>
14	<p>Refit the <i>motor cover</i> with its attachment screws and washers.</p> <p> Note Make sure the cover is tightly sealed!</p>	 <p>xx1000001102</p>
15	<p>Remove the <i>lock screw</i> from the <i>hole for lock screw</i>.</p>	 <p>xx1000001101</p>
16	<p>Perform a leak-down test of the axis 2 or 3 gearbox.</p>	<p>See section Performing a leak-down test on page 140.</p>
17	<p>Refill the gearbox with oil.</p>	<p>See section Changing oil, gearbox axes 2 and 3 on page 124.</p>

Continues on next page

4 Repair

4.6.2 Replacing motors, axes 2 and 3

Continued

	Action	Note
18	Recalibrate the robot!	Axis Calibration is described in Calibrating with Axis Calibration method on page 314 . General calibration information is included in section Calibration on page 303 .
19	 DANGER Make sure all safety requirements are met when performing the first test run.	

4.6.3 Replacing motor, axis 6

Location of motor axis 6

Motor axis 6 is located in the center of the tilthouse as shown in the figure.

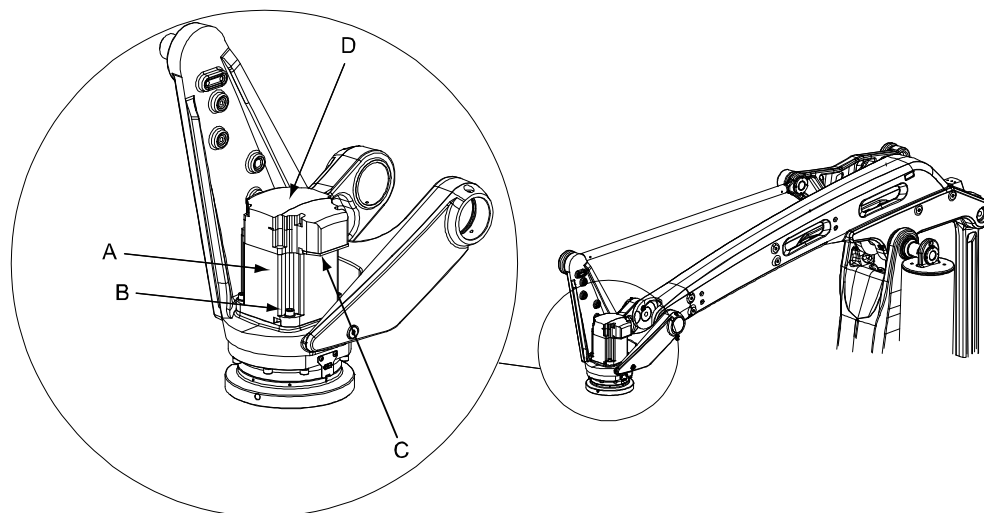

xx0600002600

A	Motor, axis 6
B	Attachment screws and washers
C	Cable gland cover
D	Motor cover

Required equipment

Equipment, etc.	Art.no.	Note
Motor axis 6	For spare part no. see: <ul style="list-style-type: none"> • Spare part lists on page 351 	Includes <ul style="list-style-type: none"> • motor • pinion • o-ring (the o-ring must be replaced when the motor is replaced)
Bits extension	3HAC12342-1	Used to reach attachment screws for motor.
Locking liquid	3HAB7116-1	Loctite 243
Power supply	-	24 VDC, 1.5 A For releasing the brakes.
Grease	3HAC042536-001	Shell Gadus S2 For lubricating the o-ring.
Standard toolkit	-	Content is defined in section Standard tools on page 346 .
Other tools and procedures may be required. See references to these procedures in the step-by-step instructions below.		These procedures include references to the tools required.

Continues on next page

4 Repair

4.6.3 Replacing motor, axis 6

Continued

Equipment, etc.	Art.no.	Note
Circuit diagram		See chapter Circuit diagrams on page 353 .

Deciding calibration routine

Decide which calibration routine to be used, based on the information in the table. Depending on which routine is chosen, action might be required prior to beginning the repair work of the robot, see the table.





	Action	Note
1	<p>Decide which calibration routine to use for calibrating the robot.</p> <ul style="list-style-type: none"> Reference calibration. External cable packages (DressPack) and tools can stay fitted on the robot. Fine calibration. All external cable packages (DressPack) and tools must be removed from the robot. 	
	<p>If the robot is to be calibrated with reference calibration:</p> <p>Find previous reference values for the axis or create new reference values. These values are to be used after the repair procedure is completed, for calibration of the robot.</p> <p>If no previous reference values exist, and no new reference values can be created, then reference calibration is not possible.</p>	<p>Follow the instructions given in the reference calibration routine on the FlexPendant to create reference values.</p> <p>Creating new values requires possibility to move the robot.</p> <p>Read more about reference calibration for Axis Calibration in <i>Product manual - IRB 4600</i>.</p>
	<p>If the robot is to be calibrated with fine calibration:</p> <p>Remove all external cable packages (DressPack) and tools from the robot.</p>	

Removing, motor axis 6

Use this procedure to remove motor, axis 6.

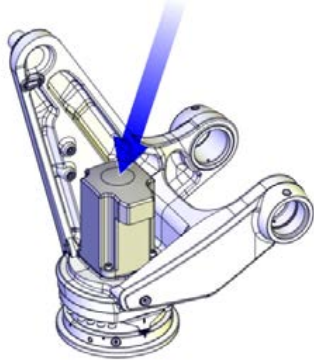
	Action	Information
1	Decide which calibration routine to use, and take actions accordingly prior to beginning the repair procedure.	
2	<p>Run the robot to a position where it is easiest to remove the motor axis 6 when standing in front of the robot.</p> <p> Note</p> <p>The motor axis 6 can be replaced without draining the gear oil.</p>	

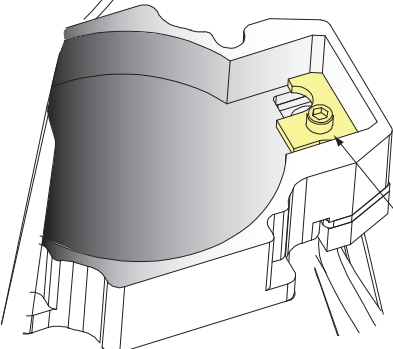
Continues on next page

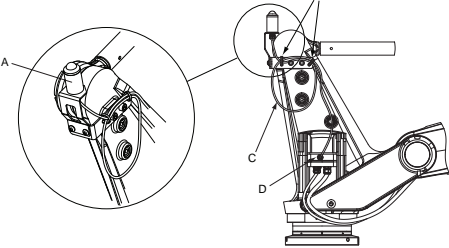

	Action	Information
3	<p> DANGER</p> <p>Turn off all:</p> <ul style="list-style-type: none"> • electric power supply • hydraulic pressure supply • air pressure supply <p>to the robot, before entering the robot working area.</p>	
4	Remove <i>motor cover</i> .	 <p>xx1000001106</p>
5	<p>Remove the <i>cable gland cover</i> at the cable exit by unscrewing its <i>attachment screw (A)</i> on the inside.</p> <p> Note</p> <p>Make sure the gasket is not damaged!</p>	 <p>xx0600002694</p>
6	<p>Disconnect all connectors beneath the cover.</p> <p> Note</p> <p>The connection to the <i>UL lamp</i>, must also be disconnected, if the robot is equipped with one.</p>	 <p>xx0500002466</p> <p>A Signal lamp (UL lamp) B Cable straps, outdoor C Cable D Connection point to the cable gland</p>

Continues on next page

4 Repair

4.6.3 Replacing motor, axis 6

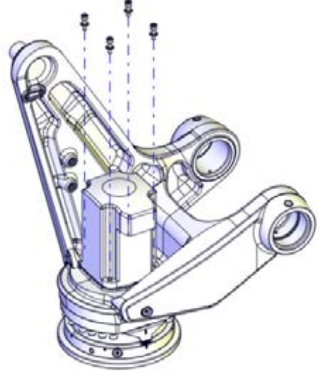

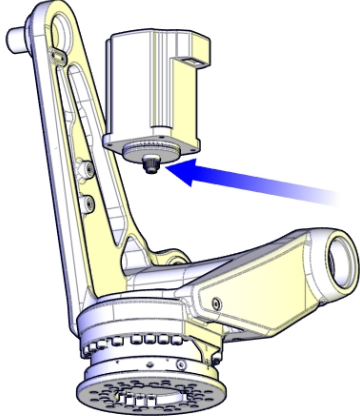
Continued

	Action	Information
7	In order to release the brake, connect the 24 VDC power supply.	Connect to connector R2.MP6 <ul style="list-style-type: none"> • + : pin 2 • -: pin 5
8	Remove <i>attachment screws</i> and <i>washers</i> . Use the bits extension.	 xx1000001012
9	If required, press the motor out of position by fitting two screws in the motor attachment holes diagonal to each other	Always use the screws for removal in pairs!
10	Lift the motor carefully to get the <i>pinion</i> away from the gear.  Note Make sure the <i>pinion</i> does not get damaged!	 xx1000001108
11	Disconnect the brake release voltage.	
12	Remove the motor by gently lifting it straight up and place it on a secure surface.	

Continues on next page

Refitting, motor axis 6

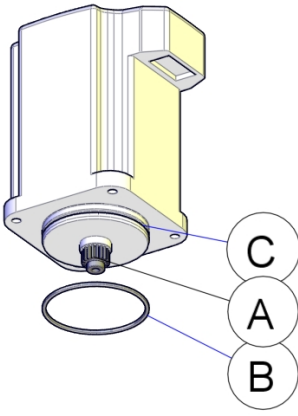
Use this procedure to refit motor axis 6.

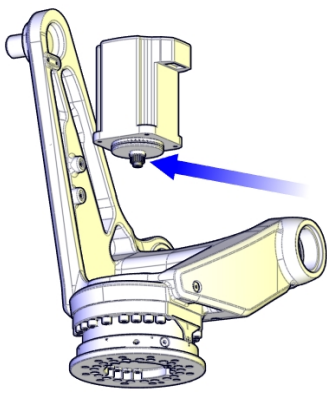
	Action	Information
1	<p>Make sure the <i>o-ring</i> on the <i>circumference</i> of the motor is seated properly. Lightly lubricate the o-ring with grease.</p> <p> Note</p> <p>The o-ring must be replaced when the motor is replaced.</p>	 <p>xx1000001109</p> <p>Parts:</p> <ul style="list-style-type: none"> • A: Pinion • B: O-ring • C: Circumference
2	<p>In order to release the brake, connect the 24 VDC power supply.</p>	<p>Connect to connector R2.MP6</p> <ul style="list-style-type: none"> • + : pin 2 • - : pin 5
3	<p>Fit the two <i>guide pins</i> in two of the motor attachment holes.</p>	<p>Art. no. is specified in Required equipment on page 267.</p>
4	<p>Lift the motor carefully in place. Make sure the motor <i>pinion</i> is properly mated to the gearbox, axis 6.</p> <p> Note</p> <p>Make sure the motor is turned the correct way. See figure!</p>	 <p>xx1000001108</p>
5	<p>Remove the guide pins.</p>	
6	<p>Apply <i>locking liquid</i> (<i>Loctite 243</i>) on the attachment screws.</p>	

Continues on next page



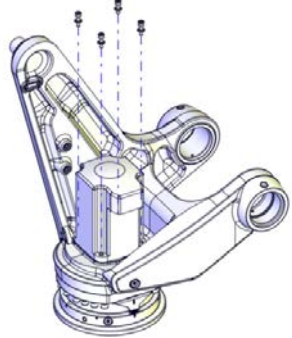
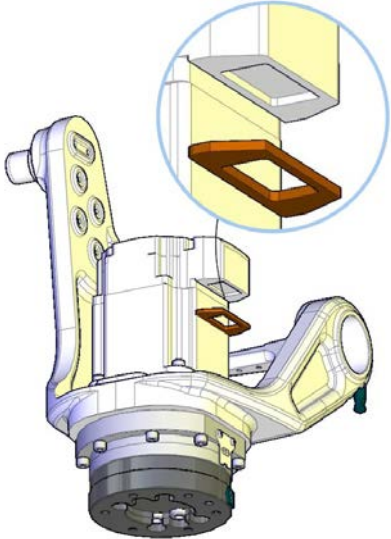

4 Repair

4.6.3 Replacing motor, axis 6

Continued

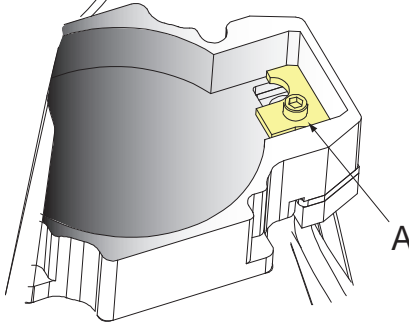
	Action	Information
7	<p>Secure the motor with its four <i>attachment screws</i> and <i>washers</i>.</p> <p>Reused screws may be used, providing they are lubricated as detailed in section Screw joints on page 342 before fitting.</p>	 <p>xx1000001012</p> <p>Washers:</p> <ul style="list-style-type: none"> • 8.4x16x1.6 quality Steel-A2F <p>Attachment screws:</p> <ul style="list-style-type: none"> • M10 x 40 quality 8.8-A2F <p>Tightening torque:</p> <ul style="list-style-type: none"> • 50 Nm
8	<p>Disconnect the brake release voltage.</p>	
9	<p>Perform a leak-down test of the axis 6 gearbox.</p>	<p>See section Performing a leak-down test on page 140.</p>
10	<p>Reconnect all connectors in motor axis 6.</p>	<p>Connect in accordance with markings on connectors.</p>
11	<p>Refit the connections to the UL lamp, if the robot is equipped with one.</p>	
12	<p>Check the <i>gasket</i>. If damaged, replace it.</p>	 <p>xx1000001224</p>

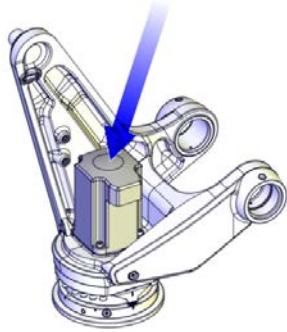
Continues on next page

	Action	Information
13	Refit the cable gland with its attachment screw.	 <p>xx0600002694</p> <ul style="list-style-type: none"> • A: Screw holding the cable gland <p>Make sure the gasket is not damaged! Replace if damaged.</p>
14	Refit the cover, motor axis 6 with its <i>attachment screws and washers</i> .  Note Make sure the cover is tightly sealed!	 <p>xx1000001106</p>
15	Re-calibrate the robot!	Axis Calibration is described in Calibrating with Axis Calibration method on page 314 . General calibration information is included in section Calibration on page 303 .
16	 DANGER Make sure all safety requirements are met when performing the first test run.	

4 Repair

4.7.1 Replacing the axis 1 gearbox

4.7 Gearboxes

4.7.1 Replacing the axis 1 gearbox

Location of gearbox

The axis 1 gearbox is located between the frame and base as shown in the figure.

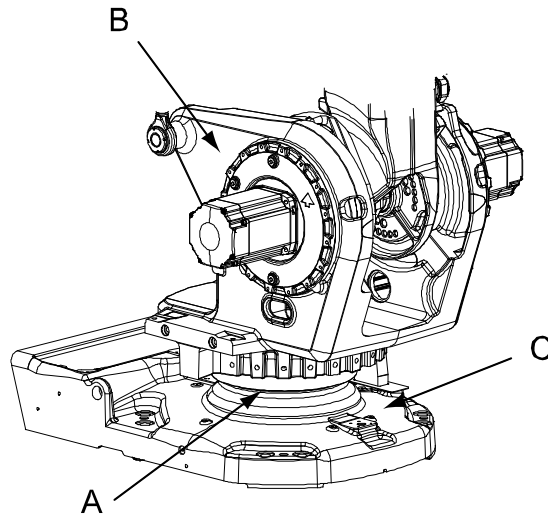

xx0600002631

A	Gearbox, axis 1
B	Frame
C	Base

Required equipment

Equipment, etc.	Art. no.	Note
Gearbox	For spare part no. see: • Spare part lists on page 351.	Includes: • gearbox • all o-rings and sealing rings
O-ring	3HAB3772-54	Replace if damaged!
O-ring	3HAB3772-55	Replace if damaged!
Sealing ring	3HAC11581-4	Replace if damaged!
Grease	3HAC042536-001	Shell Gadus S2 For lubricating the o-ring.
Support, base and gear 1	3HAC15535-1	
Lifting accessory, base	3HAC15560-1	
Lifting accessory (chain)	3HAC15556-1	
Guide pins		2 pcs, M16x150. Used for guiding the gearbox into place in the base. Always use guide pins in pairs!

Continues on next page

Equipment, etc.	Art. no.	Note
Calibration tool box, Axis Calibration	3HAC055412-001	Delivered as a set of calibration tools. Required if Axis Calibration is the valid calibration method for the robot.
Standard toolkit	-	Content is defined in section Standard tools on page 346 .
Other tools and procedures may be required. See references to these procedures in the step-by-step instructions below.		These procedures include references to the tools required.

Deciding calibration routine

Decide which calibration routine to be used, based on the information in the table. Depending on which routine is chosen, action might be required prior to beginning the repair work of the robot, see the table.

	Action	Note
1	Decide which calibration routine to use for calibrating the robot. <ul style="list-style-type: none"> Reference calibration. External cable packages (DressPack) and tools can stay fitted on the robot. Fine calibration. All external cable packages (DressPack) and tools must be removed from the robot. 	
	<p>If the robot is to be calibrated with reference calibration:</p> <p>Find previous reference values for the axis or create new reference values. These values are to be used after the repair procedure is completed, for calibration of the robot.</p> <p>If no previous reference values exist, and no new reference values can be created, then reference calibration is not possible.</p>	<p>Follow the instructions given in the reference calibration routine on the FlexPendant to create reference values.</p> <p>Creating new values requires possibility to move the robot.</p> <p>Read more about reference calibration for Axis Calibration in <i>Product manual - IRB 4600</i>.</p>
	<p>If the robot is to be calibrated with fine calibration:</p> <p>Remove all external cable packages (DressPack) and tools from the robot.</p>	

Removal, gearbox axis 1

Use this procedure to remove gearbox, axis 1.



	Action	Note
1	Decide which calibration routine to use, and take actions accordingly prior to beginning the repair procedure.	

Continues on next page

4 Repair

4.7.1 Replacing the axis 1 gearbox

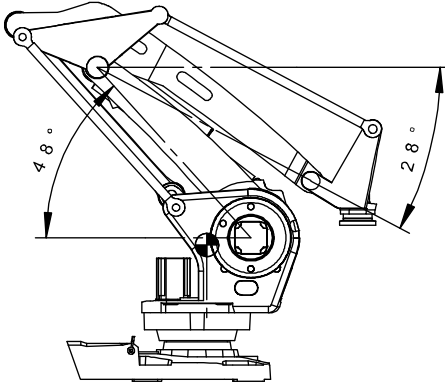
Continued

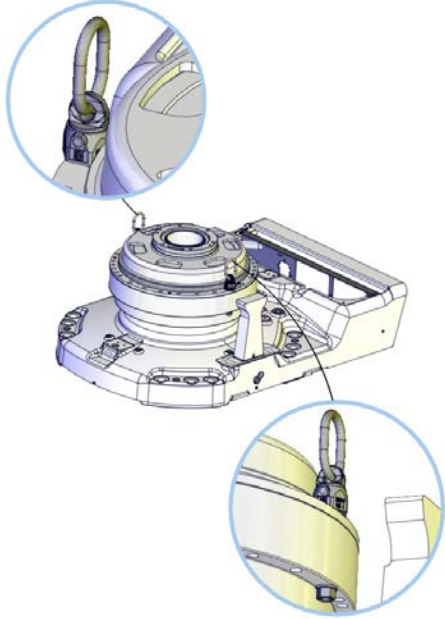
	Action	Note
2	Move the robot to its most stable position, shown in the figure to the right.	 <p>xx0500002275</p>
3	 <p>DANGER</p> <p>Turn off all:</p> <ul style="list-style-type: none"> • electric power supply • hydraulic pressure supply • air pressure supply <p>to the robot, before entering the robot working area.</p>	
4	Drain the axis 1 gearbox.	See Changing oil, axis-1 gearbox on page 121 .
5	Remove the complete arm system.	See Replacing the base, including axis 1 gearbox on page 162 .
6	Unfasten the robot base from the foundation by removing the base attachment screws.	
7	Attach the <i>lifting accessory, base and gear 1</i> and the <i>lifting tool (chain)</i> to the gearbox and base.	 <p>xx1000001395</p> <p>Specified in Required equipment on page 274.</p>

Continues on next page

4.7.1 Replacing the axis 1 gearbox
Continued

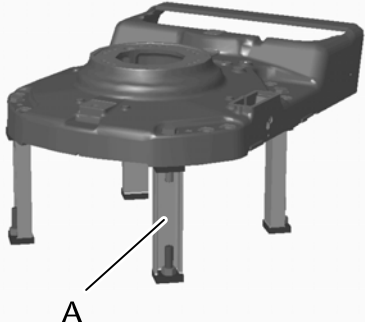
	Action	Note
8	<p> CAUTION</p> <p>The base and axis 1 gearbox weighs 130 kg + . All lifting accessories used must be sized accordingly!</p>	
9	<p>Lift the robot base including the axis 1 gearbox to allow the <i>base and gear 1 support</i> be fitted on each sides of the base.</p>	<p>Art. no. is specified in <i>Required equipment on page 274</i>.</p>
10	<p>Secure the support to the base and to the foundation. Make sure the base remains in a stable position before performing any work underneath the base!</p>	 <p>xx100000364</p> <p>A Support base (4 pcs)</p>

Continues on next page



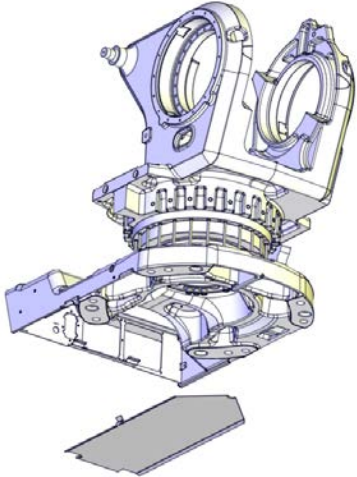
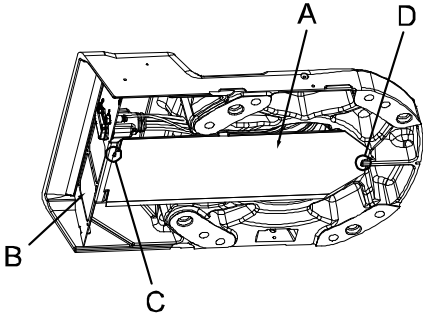
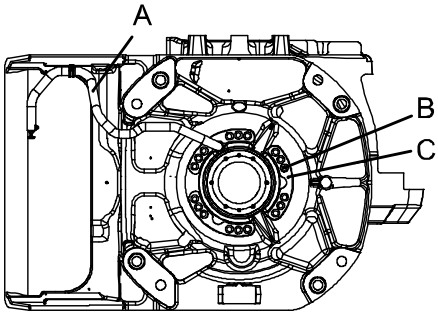

4 Repair

4.7.1 Replacing the axis 1 gearbox

Continued

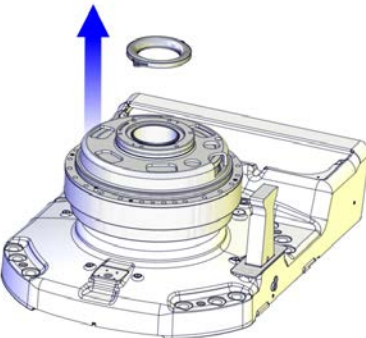
	Action	Note
11	<p>Remove the bottom plate from underneath the base in order to get access to the attachment screws.</p> <p>It may be necessary to also remove the rear connector plate.</p>	 <p>xx1000001385</p>  <p>xx0300000612</p> <ul style="list-style-type: none"> A Bottom plate B Rear connector plate C Attachment screw D Groove
12	<p>Unscrew the attachment screws and remove the washers.</p>	 <p>xx0200000227</p> <p>A view from below:</p> <ul style="list-style-type: none"> • A: Oil drain hose • B: Attachment screws, gearbox axis 1, 18 pcs • C: Washers, 3 pcs

Continues on next page

	Action	Note
13	<p>Remove the cable guide in the center of gearbox 1 by unscrewing its attachment screws.</p>	 <p>xx1000001387</p>
14	<p> CAUTION</p> <p>The gearbox weighs . All lifting accessories used must be sized accordingly!</p>	
15	<p>Lift the gearbox away with the already mounted lifting tools.</p>	
16	<p>Turn the gearbox, and remove the protection pipe by unscrewing two attachment screws.</p> <p> Note</p> <p>Move the protective pipe over to the new gearbox.</p>	 <p>xx1400000786</p>

Continues on next page

4 Repair

4.7.1 Replacing the axis 1 gearbox



Continued

Refitting, gearbox axis 1

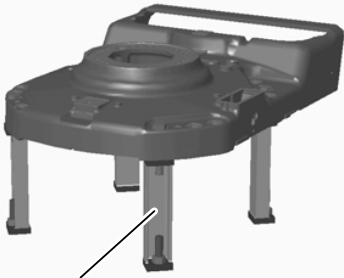
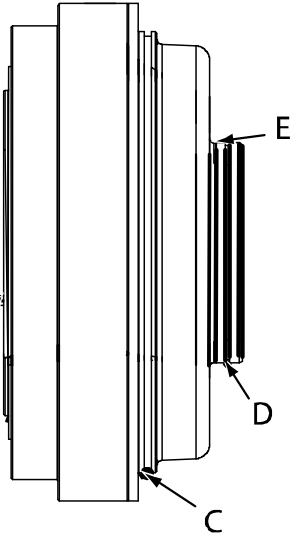
Use this procedure to refit gearbox, axis 1.

	Action	Note
1	Fit the <i>support, base and gear 1</i> to the base.	<p>Mounting of the support, base and gear 1 is detailed in section Removal, gearbox axis 1 on page 275.</p>  <p>xx1000000364</p> <p>A Support base (4 pcs)</p>
2	Make sure the two <i>o-rings</i> on the circumference of the gearbox are seated properly in their respective groove. Lubricate them with <i>grease</i> .	<p>Art no. is specified in Required equipment on page 274.</p>  <p>xx0200000055</p> <ul style="list-style-type: none"> • A: Guide pin • C: O-ring 3HAB 3772-54 • D: O-ring 3HAB 3772-55 • E: Sealing ring 3HAC 11581-4

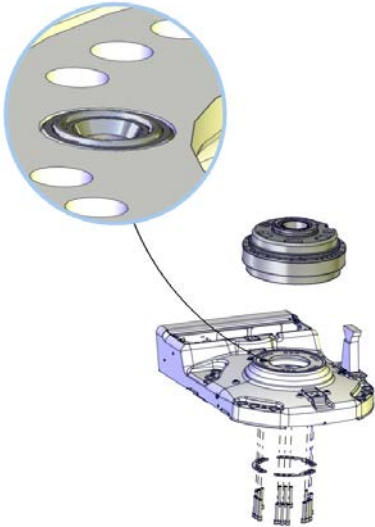
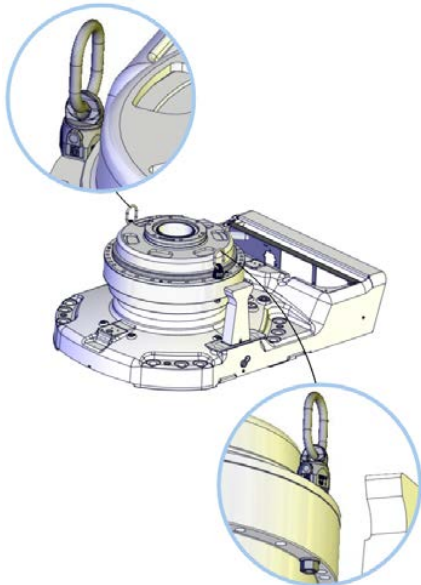
Continues on next page

	Action	Note
3	<p>Make sure the small o-ring around the oil hole is fitted properly!</p>	 <p>xx1000001392</p>
4	<p>Attach the <i>lifting accessory, base and gear 1</i> and the <i>lifting tool (chain)</i> to the gearbox.</p>	<p>Specified in Required equipment on page 274.</p>  <p>xx1000001395</p>
5	<p>Fit two <i>guide pins</i> in two of the attachment holes in the gearbox, parallel to each other.</p>	<p>Specified in Required equipment on page 274.</p>
6	<p> CAUTION</p> <p>The gearbox weighs . All lifting accessories used must be sized accordingly!</p>	

Continues on next page

4 Repair

4.7.1 Replacing the axis 1 gearbox

Continued

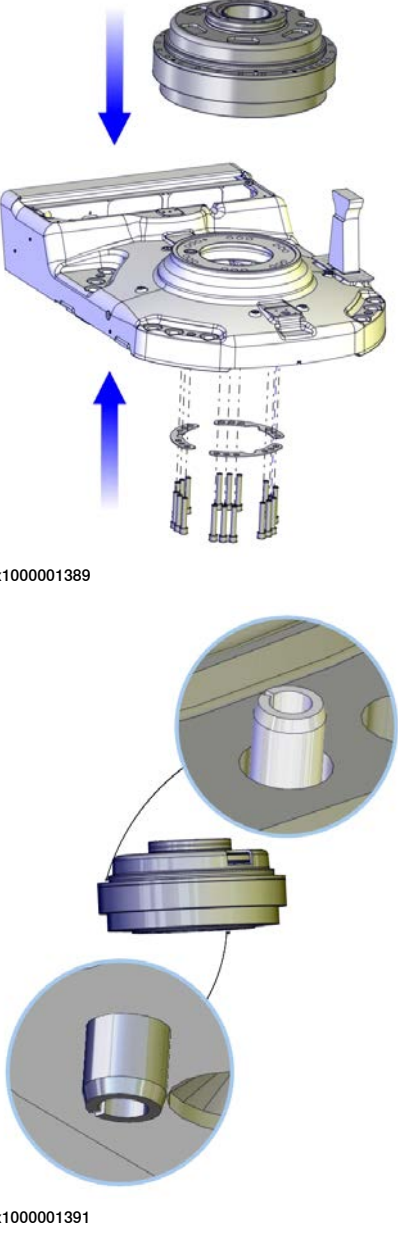
	Action	Note
7	<p>Lift the gearbox.</p> <p>Make sure the guide pin in the bottom face of the gearbox is properly aligned with the base.</p>	 <p>xx1000001389</p> <p>xx1000001391</p>
8	<p>Lift gearbox axis 1 onto the guide pins and lower it carefully to its mounting position.</p>	<p>Always use guide pins in pairs!</p>

Continues on next page

4.7.1 Replacing the axis 1 gearbox

Continued

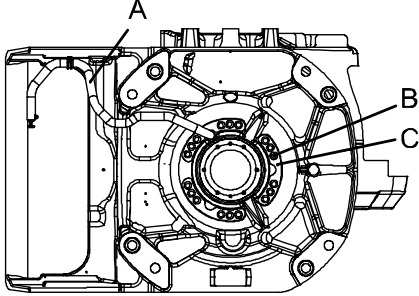
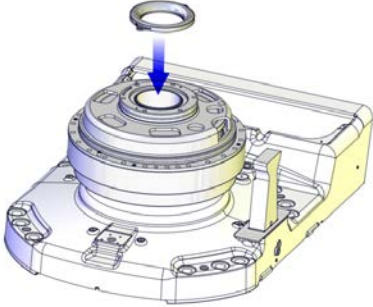



	Action	Note
9	Secure the gearbox with its <i>attachment screws</i> and washers.	<p>18 pcs, M16 x 70, 12.9 quality UN-BRAKO.</p> <p>Tightening torque: 300 Nm</p> <p>Reused screws may be used, providing they are lubricated as detailed in section Screw joints on page 342 before fitting.</p>  <p>xx0200000227</p> <p>A view from below:</p> <ul style="list-style-type: none"> • A: Oil drain hose • B: Attachment screws, gearbox axis 1, 18 pcs • C: Washers, 3 pcs
10	Refit the cable guide in the center of gearbox 1 with its attachment screws.	 <p>xx1000001393</p>

Continues on next page

4 Repair

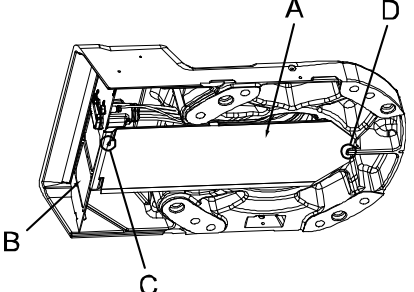
4.7.1 Replacing the axis 1 gearbox

Continued

	Action	Note
11	<p>Refit the bottom plate underneath the robot base by pushing it into the groove and fitting the attachment screw.</p> <p>If removed, also refit the rear connector plate.</p> <p> Note</p> <p>Direct the bends on the bottom plate downwards!</p>	<p>1 screw: M6 x 8.</p>  <p>xx0300000612</p> <ul style="list-style-type: none"> • A: Bottom plate • B: Rear connector plate • C: Attachment screw • D: Groove
12	<p> CAUTION</p> <p>The base and axis 1 gearbox weighs 130 kg + .</p> <p>All lifting accessories used must be sized accordingly!</p>	
13	Lift the robot base and gearbox 1 and remove the base and gear support.	
14	Secure the base to the mounting site.	See Orienting and securing the robot on page 69 .
15	<p>Refit the complete arm system.</p> <p> CAUTION</p> <p>This is a complex task to be performed with utmost care in order to avoid injury or damage!</p>	See Replacing the base, including axis 1 gearbox on page 162 .
16	Perform a leak-down test.	See section Performing a leak-down test on page 140 .
17	Refill the gearbox with oil.	See Changing oil, axis-1 gearbox on page 121 .
18	Recalibrate the robot.	<p>Axis Calibration is described in Calibrating with Axis Calibration method on page 314.</p> <p>General calibration information is included in section Calibration on page 303.</p>
19	<p> DANGER</p> <p>Make sure all safety requirements are met when performing the first test run.</p>	

4.7.2 Replacing the gearbox, axes 2- 3

Location of gearbox, axes 2-3

The axis-2 and axis-3 gearboxes are located on either side of the frame as shown in the figure.

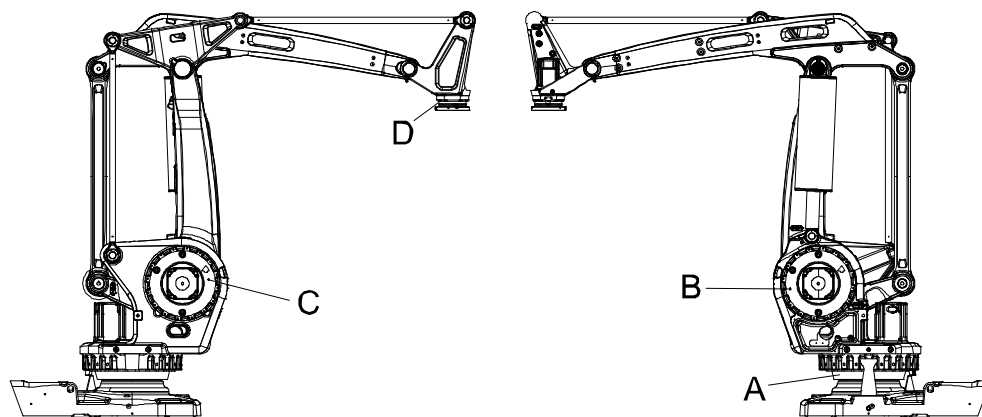

xx0500002467

A	Gearbox, axis 1
B	Gearbox, axis 2
C	Gearbox, axis 3
D	Gearbox, axis 6

Required equipment

Equipment, etc.	Art.no	Note
Gearbox, axes 2-3	For spare part no. see: • Spare part lists on page 351.	
Sealing axes 2-3	3HAC022379-001	Always replace.
O-ring	3HAB3772-127	Replace if damaged.
Lock screw M16x55	-	Use to lock the lower arm.
Screw M12x50	-	2 pcs. Use to unload the balancing device.
Screw M12x100	-	2 pcs, must have full thread. Use to press the gearbox free from the frame.
Guide pins M12	-	Use guide pins in pairs.
Lifting accessory	-	Roundsling and a rotating lifting point. Lifting capacity: 100 kg. Used to lift the gearbox.
Guide sleeves	3HAC14628-1/2	Use to keep the sealing in place.
Grease		Use to lubricate surfaces on the gearbox for easier assembly.

Continues on next page

4 Repair

4.7.2 Replacing the gearbox, axes 2- 3

Continued

Equipment, etc.	Art.no	Note
Bearing grease	3HAC042536-001	Shell Gadus S2 Option Foundry Plus
Rust preventive	3HAC034903-001	Mercasol 3110 Waxcoat
Standard toolkit		Content is defined in section Standard tools on page 346 .
Other tools and procedures may be required. See references to these procedures in the step-by-step instructions below.		These procedures include references to the tools required.

Deciding calibration routine

Decide which calibration routine to be used, based on the information in the table. Depending on which routine is chosen, action might be required prior to beginning the repair work of the robot, see the table.

	Action	Note
1	Decide which calibration routine to use for calibrating the robot. <ul style="list-style-type: none"> Reference calibration. External cable packages (DressPack) and tools can stay fitted on the robot. Fine calibration. All external cable packages (DressPack) and tools must be removed from the robot. 	
	If the robot is to be calibrated with reference calibration: Find previous reference values for the axis or create new reference values. These values are to be used after the repair procedure is completed, for calibration of the robot. If no previous reference values exist, and no new reference values can be created, then reference calibration is not possible.	Follow the instructions given in the reference calibration routine on the FlexPendant to create reference values. Creating new values requires possibility to move the robot. Read more about reference calibration for Axis Calibration in <i>Product manual - IRB 4600</i> .
	If the robot is to be calibrated with fine calibration: Remove all external cable packages (DressPack) and tools from the robot.	

Removal, axis-2 / axis-3 gearbox

Use this procedure to remove the axis-2 or axis-3 gearbox.



Note

Do not replace both gearboxes at the same time, unless the complete arm system is already removed!

	Action	Note
1	Decide which calibration routine to use, and take actions accordingly prior to beginning the repair procedure.	

Continues on next page

4.7.2 Replacing the gearbox, axes 2- 3
Continued

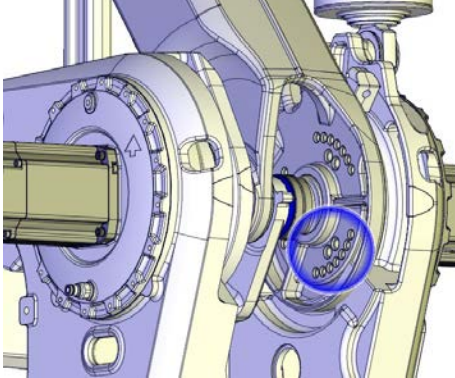
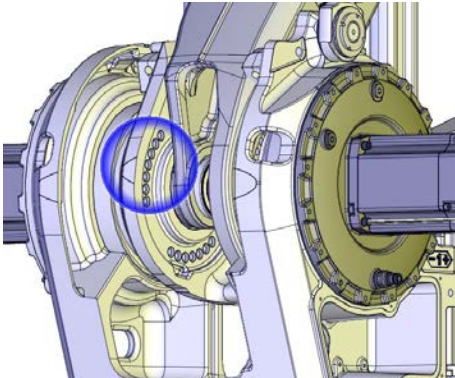

	Action	Note
2	<p>When removing axis 2 gearbox: Run the axis 2 to -42° and all other axes to 0° (calibration position).</p> <p>When removing axis 3 gearbox: Run the axis 2 to -40°, axis 3 to $+15^{\circ}$ and all other axes to 0°.</p>	
3	<p>When removing axis 2 gearbox: Remove all screws in the lower screw area on the inside of the lower arm (7 pcs M12, 2 pcs M16). See figure.</p> <p>When removing axis 3 gearbox: Remove all screws in the upper front screw area and three screws in the upper back area.</p>	<p>Axis 2:</p>  <p>xx110000623</p> <p>Axis 3:</p>  <p>xx110000624</p>
4	Run axis 2 to 0° .	

Continues on next page

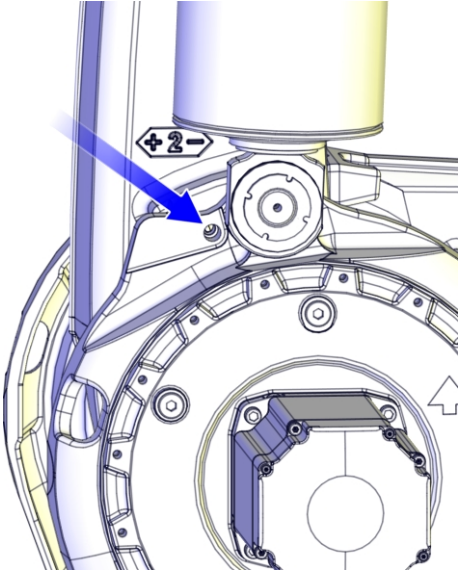

4 Repair

4.7.2 Replacing the gearbox, axes 2- 3

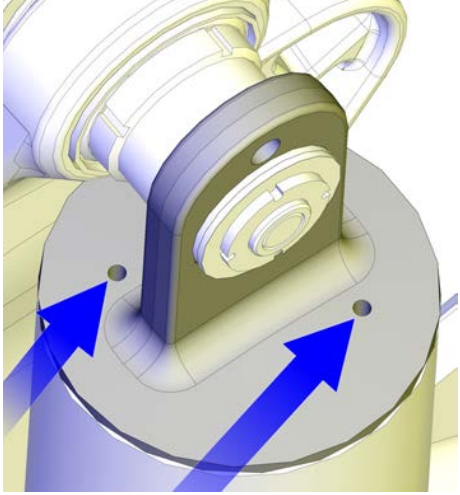
Continued

	Action	Note
5	<p>Fit the <i>lock screw</i> in the lower arm to secure axis 2.</p> <p> CAUTION</p> <p>Tighten by hand!</p>	 <p>xx1000001101</p>
6	Secure the weight of the upper arm with roundslings in an overhead crane.	
7	Raise the lifting equipment to take the weight of the upper arm.	
8	Release the brakes of axis 2 to rest the weight of the axis against the lock screw.	
9	Release the brakes of axis 3 to rest the weight of the axis by the roundslings and overhead crane.	
10	<p>Remove the two plastic screws in the upper end of the balancing device.</p> <p> Note</p> <p>Keep the plastic screws. They will be refitted later.</p>	 <p>xx1000001111</p>

Continues on next page

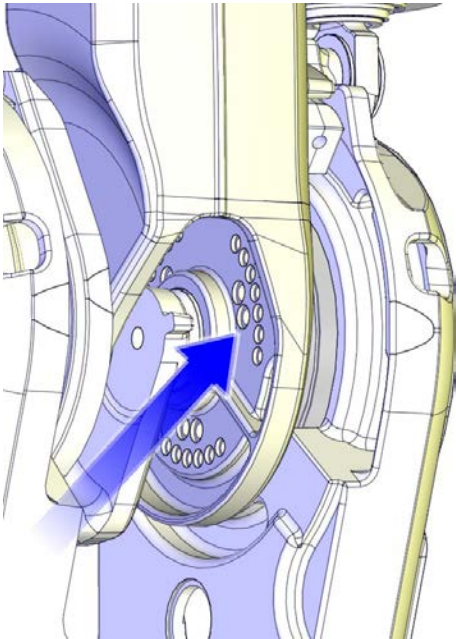



	Action	Note
11	Insert two screws, <i>M12x50</i> in the holes to neutralize the spring force. Screw in the screws until they have proper contact with the cylinder inside. The length of the cylinder is now locked and the balancing device is unloaded. It should now be possible to easily rotate the balancing device.	See the previous figure!
12	 DANGER Turn off all: <ul style="list-style-type: none"> • electric power supply • hydraulic pressure supply • air pressure supply to the robot, before entering the robot working area.	
13	Drain the gearbox.	Detailed in section Draining, axes 2 and 3 on page 126 .  Note Time-consuming activity!
14	Remove the motor cables of axis-2 or axis-3 motor, depending on which gearbox is being removed. Protect the cables from getting damaged and from oil spill.	
15	Remove one gearbox at a time!	
16	Remove the axis-2 or axis-3 motor, depending on which gearbox is being removed.	Detailed in section Replacing motors, axes 2 and 3 on page 256
17	Remove all remaining <i>attachment screws</i> that secure the gearbox to the lower arm system. Axis 2: M16 and M12. Axis 3: M12.	 xx1000001405

Continues on next page

4 Repair

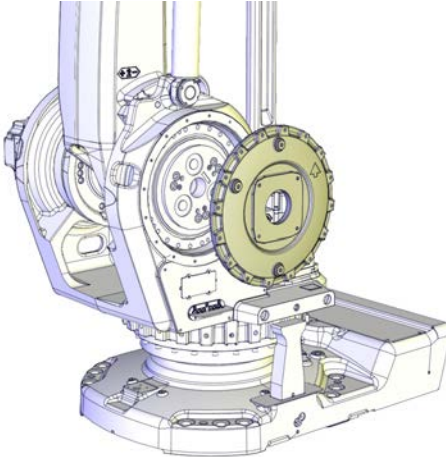

4.7.2 Replacing the gearbox, axes 2- 3

Continued

	Action	Note
18	Remove the gearbox cover by removing its attachment screws.	 <p data-bbox="954 779 1054 797">xx120000628</p>
19	Remove two opposite screws of the attachment screws that hold the gearbox and replace them with two guide pins.	 Note Always use guide pins in pairs!
20	Remove the remaining attachment screws.	
21	Fit the <i>lifting accessory</i> to the gearbox.	Art. no. is specified in Required equipment on page 285 .
22	 CAUTION The gearbox weighs 69 kg. All lifting accessories used must be sized accordingly!	
23	If required, apply two <i>screws, M12x100</i> to the holes in the gearbox, in order to press it free. (The screws need to have a full thread.)	
24	 CAUTION When the gearbox comes free from the frame and comes off the guide pins it will tilt and there is a risk of damage to the gearbox surfaces! Be aware of this and remove the gearbox carefully!	

Continues on next page

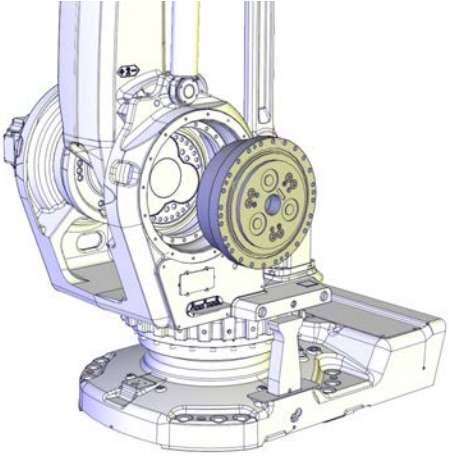
4.7.2 Replacing the gearbox, axes 2-3
Continued

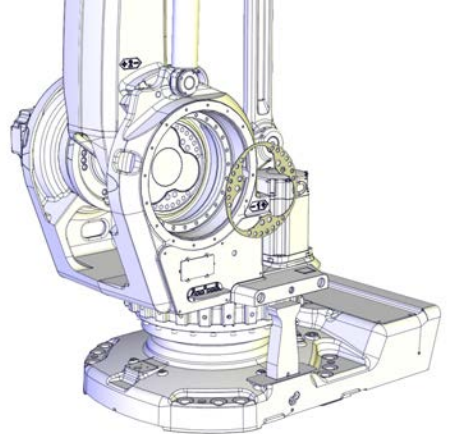
	Action	Note
25	Remove the gearbox axis 2-3 using an overhead crane or similar, with guidance from the fitted guide pins.	 <p data-bbox="975 770 1086 792">xx120000629</p>
26	Remove the sealing from the lower arm and clean it.  Note The sealing can hang onto the gearbox, sticking to the oil.	 <p data-bbox="975 1263 1086 1285">xx120000630</p>

Continues on next page

4 Repair

4.7.2 Replacing the gearbox, axes 2- 3



Continued

Refitting, axis-2 / axis-3 gearbox

Use this procedure to refit the axes-2 or axis-3 gearbox.

	Action	Note
1	<p>Make sure that the o-ring is fitted to the gearbox. Lightly lubricate it with <i>grease</i>.</p>	<div data-bbox="1002 434 1342 1010" data-label="Image"> </div> <p data-bbox="948 1043 1054 1061">xx1000001404</p> <p data-bbox="948 1081 1347 1137">Specified in Required equipment on page 285.</p>
2	<p>Fit two <i>guide pins</i> in the frame. Use two of the attachment holes for the screws that hold the gearbox.</p>	
3	<p> CAUTION</p> <p>The gearbox weighs 69 kg! All lifting equipment used must be sized accordingly!</p>	
4	<p>Fit the <i>lifting accessory</i> to the gearbox and lift it with an overhead crane.</p>	<p>Specified in Required equipment on page 285.</p>

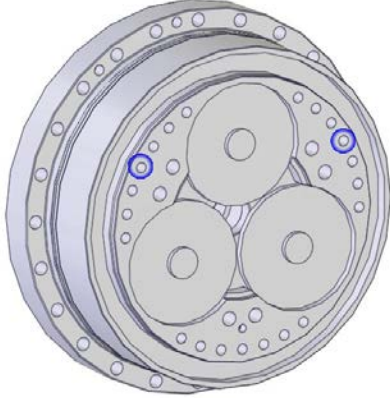
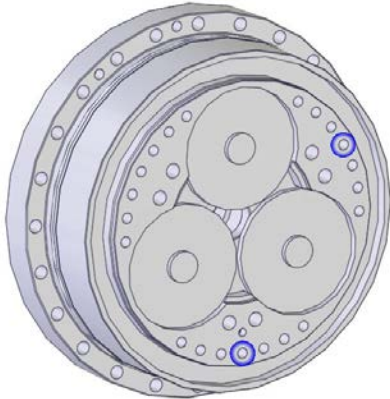
Continues on next page

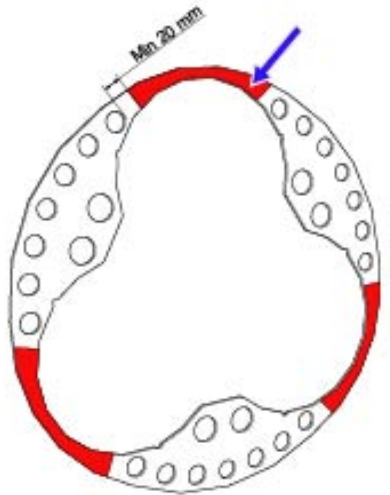

	Action	Note
5	<p>Fit a new <i>sealing</i> to the gearbox and secure it to the gearbox by using two <i>guide sleeves</i>.</p> <p>When refitting axis 2 gearbox: Insert the guide sleeves in the two middle holes of the upper screw areas.</p> <p>When refitting axis 3 gearbox: Insert one guide sleeve in the middle screw hole in the upper back area and one guide sleeve in the middle screw hole in the the lower area.</p>	<p>Art. no. is specified in Required equipment on page 285.</p> <p>Axis 2:</p>  <p>xx1100000621</p> <p>Axis 3:</p>  <p>xx1100000622</p>
6	<p>Foundry Plus: Apply bearing grease on the highlighted areas on both sides of the sealing.</p> <p> Note</p> <p>Do not apply grease closer than 20 mm from the edge of the holes in the sealing.</p>	 <p>xx1400000993</p>

Continues on next page

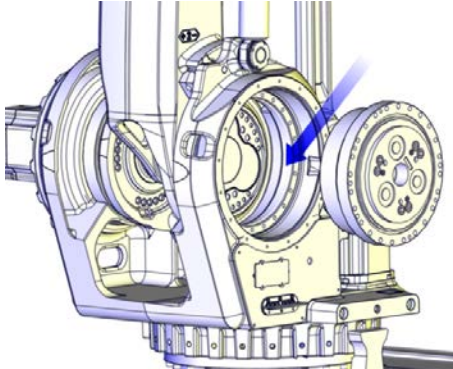

4 Repair

4.7.2 Replacing the gearbox, axes 2- 3

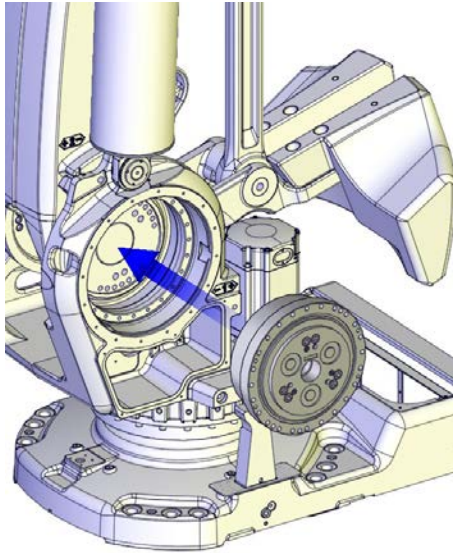
Continued

	Action	Note
	<p><i>Foundry Plus:</i> Apply rust preventive on the highlighted area.</p>	 <p>xx1400001132</p>
7	Lubricate necessary surfaces of the gearbox with <i>grease</i> in order to make it easier to insert the gearbox into the frame.	Specified in Required equipment on page 285 .
8	<p>Put the gearbox onto the guide pins and slide it carefully into place in the frame.</p> <p> Note Check that the sealing is in place during the procedure.</p>	 <p>xx1000001406</p>
9	Use a crank to move the gears in order to find the holes for the attachment screws.	
10	Secure the gearbox to the lower arm with the <i>attachment screws</i> and <i>washers</i> in two of the screw areas (the third is not reachable at this point). Do not remove the guide sleeves yet.	<p>Axis 2 M12x60 quality 12.9 Gleitmo (6+6 pcs) • Tightening torque: 120 Nm. M16x90 quality 12.9 Gleitmo (2+2 pcs) • Tightening torque: 300 Nm.</p> <p>Axis 3 M12x60 quality 12.9 Gleitmo • Tightening torque: 120 Nm.</p>
11	Remove the two guide sleeves and replace them with the two remaining M12 screws.	M12x60 quality 12.9 Gleitmo (1+1 pc) • Tightening torque: 120 Nm.
12	Secure the gearbox to the frame.	M12, quality 8.8-A2F Tightening torque: 120 Nm.

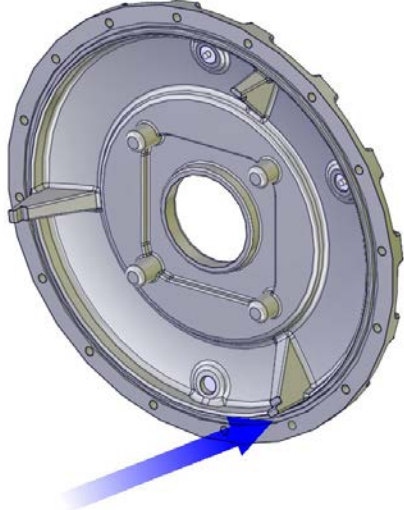
Continues on next page

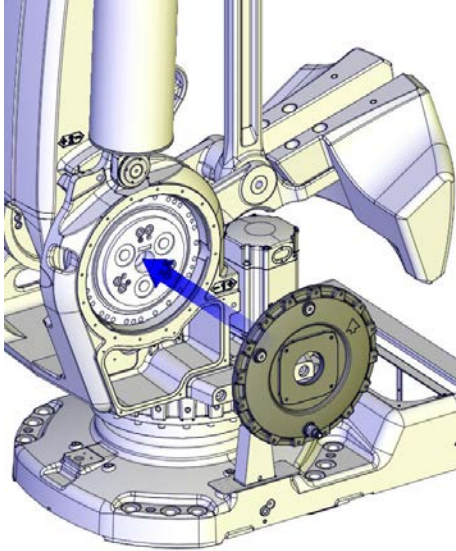

	Action	Note
13	Clean the gearbox of residual grease.	
14	Apply locking liquid in the attachment holes for the gearbox cover.	Loctite 243.
15	Fit the <i>o-ring</i> in the cover.	 <p data-bbox="975 1070 1086 1093">xx1000001407</p>
16	Refit the cover with its attachment screws and washers.  Note Fit the cover so that the arrow on the cover points upwards!	M8x35 quality 8.8-A2F (12 pcs) Tightening torque: 24 Nm  <p data-bbox="975 1839 1086 1861">xx1000001408</p>
17	Refit the <i>motors axes 2-3</i> .	See Replacing motors, axes 2 and 3 on page 256
18	Perform a leakdown test.	See Performing a leak-down test on page 140 .

Continues on next page

4 Repair

4.7.2 Replacing the gearbox, axes 2- 3

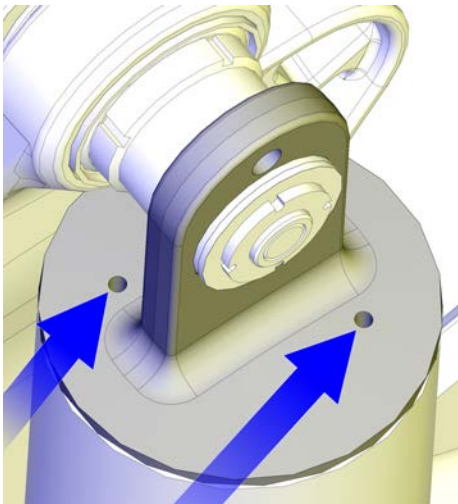
Continued

	Action	Note
19	Refill the gearbox axes 2-3 with oil.	See Filling, axes 2 and 3 on page 126
20	Remove the screws that unload the balancing device and put back the plastic screws.	 <p data-bbox="946 862 1053 884">xx1000001111</p>
21	Remove the lock screw from the lower arm.	
22	Run the axes 2 and 3 to a position where the remaining screws in the lower arm can be fitted.	<p data-bbox="946 965 1021 987">Axis 2</p> <p data-bbox="946 996 1345 1019">M12x60 quality 12.9 Gleitmo (6 pcs)</p> <ul data-bbox="978 1028 1321 1050" style="list-style-type: none"> • Tightening torque: 120 Nm. <p data-bbox="946 1059 1345 1081">M16x90 quality 12.9 Gleitmo (2 pcs)</p> <ul data-bbox="978 1090 1321 1113" style="list-style-type: none"> • Tightening torque: 300 Nm. <p data-bbox="946 1122 1021 1144">Axis 3</p> <p data-bbox="946 1153 1262 1176">M12x60 quality 12.9 Gleitmo</p> <ul data-bbox="978 1184 1321 1207" style="list-style-type: none"> • Tightening torque: 120 Nm.
23	Recalibrate the robot.	<p data-bbox="946 1229 1406 1279">Axis Calibration is described in Calibrating with Axis Calibration method on page 314.</p> <p data-bbox="946 1288 1406 1337">General calibration information is included in section Calibration on page 303.</p>
24	 <p data-bbox="563 1395 671 1417">DANGER</p> <p data-bbox="467 1449 938 1503">Make sure all safety requirements are met when performing the first test run.</p>	

4.7.3 Replacing gearbox axis 6

Location of gearbox axis 6

The axis 6 gearbox is located in the center of the wrist as shown in the figure.

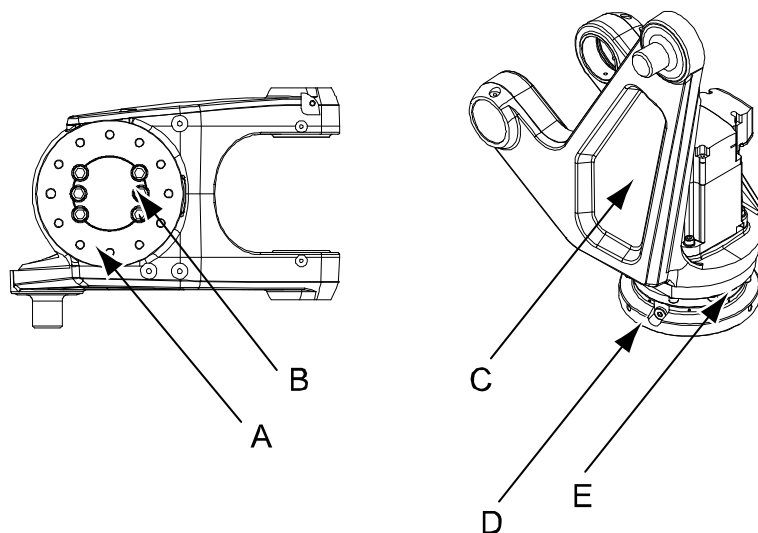

xx0600002627

A	Turning disk
B	Attachment screws (6 pcs) turning disk
C	Tilthouse unit
D	Gearbox, axis 6
E	Attachment screws and washers, gearbox axis 6

Required equipment

Equipment	Art. no.	Note
Gearbox axis 6	For spare part no. see: <ul style="list-style-type: none"> Spare part lists on page 351. 	Includes o-ring
Turning disk	For spare part no. see: <ul style="list-style-type: none"> Spare part lists on page 351. 	
Washers	3HAA1001-172	Not included in gearbox. Replace only if damaged!
O-ring (type 2) 164.7x3.53	3HAB3772-57	Must be replaced when reassembling gearbox.
O-ring (type 2) 150.0x2.0	3HAB3772-64	Must be replaced when reassembling gearbox.
O-ring (type 2) 12 pcs 13.1x1.6	3HAB3772-61	Must be replaced when reassembling gearbox.
Grease	3HAC042536-001	Shell Gadus S2 Used to lubricate the o-ring

Continues on next page

4 Repair

4.7.3 Replacing gearbox axis 6

Continued

Equipment	Art. no.	Note
Guide pins	-	Always use guide pins in pairs!
Standard toolkit		The content is defined in the section Standard tools on page 346 .
Other tools and procedures may be required. See references to these procedures in the step-by-step instructions below.		These procedures include references to the tools required.

Deciding calibration routine

Decide which calibration routine to be used, based on the information in the table. Depending on which routine is chosen, action might be required prior to beginning the repair work of the robot, see the table.

	Action	Note
1	Decide which calibration routine to use for calibrating the robot. <ul style="list-style-type: none">Reference calibration. External cable packages (DressPack) and tools can stay fitted on the robot.Fine calibration. All external cable packages (DressPack) and tools must be removed from the robot.	
	If the robot is to be calibrated with reference calibration: Find previous reference values for the axis or create new reference values. These values are to be used after the repair procedure is completed, for calibration of the robot. If no previous reference values exist, and no new reference values can be created, then reference calibration is not possible.	Follow the instructions given in the reference calibration routine on the FlexPendant to create reference values. Creating new values requires possibility to move the robot. Read more about reference calibration for Axis Calibration in <i>Product manual - IRB 4600</i> .
	If the robot is to be calibrated with fine calibration: Remove all external cable packages (DressPack) and tools from the robot.	

Removing gearbox axis 6

Use this procedure to remove gearbox axis 6.

	Action	Note
1	Decide which calibration routine to use, and take actions accordingly prior to beginning the repair procedure.	
2	Jog the robot to a position where the tilt-house unit is placed in an appropriate service position.	

Continues on next page

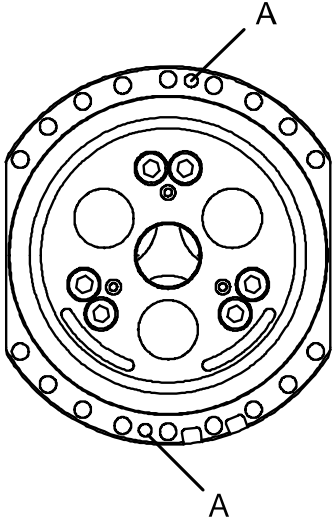
	Action	Note
3	 DANGER Turn off all: <ul style="list-style-type: none"> • electric power supply • hydraulic pressure supply • air pressure supply to the robot, before entering the robot working area.	
4	Drain the <i>oil</i> from the gearbox.	See section <ul style="list-style-type: none"> • Changing oil, gearbox axis 6 on page 128
5	Remove the <i>turning disk</i> .	See section <ul style="list-style-type: none"> • Replacing the turning disk on page 170
6	Remove the gearbox by unscrewing the <i>attachment screws</i> and <i>washers</i> that secure it.	
7	If required apply two M8 screws in the holes shown in the figure, and press out the gearbox.	 <p>xx0200000220</p> <p>A: M8 holes for pressing out the gearbox</p>

Continues on next page

4 Repair

4.7.3 Replacing gearbox axis 6

Continued

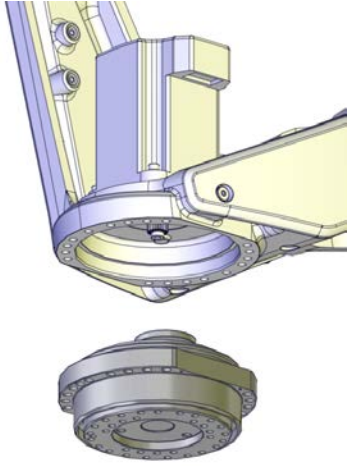

	Action	Note
8	Remove <i>gearbox axis 6</i> carefully without damaging pinion or gear.	 xx1000001412
9	Check the pinion. A damaged pinion must be replaced!	

Refitting gearbox axis 6

Use this procedure to refit gearbox axis 6.

	Action	Note
1	 DANGER Turn off all: <ul style="list-style-type: none">• electric power supply• hydraulic pressure supply• air pressure supply to the robot, before entering the robot working area.	

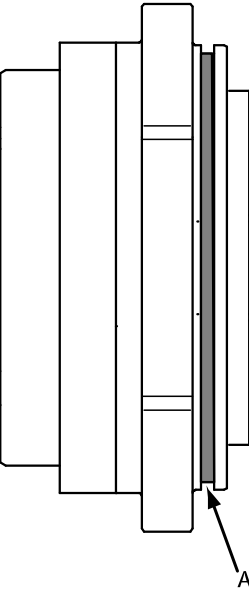
Continues on next page

	Action	Note
2	<p>Make sure the <i>o-ring</i> is undamaged and fitted to the gearbox. If the o-ring is damaged, replace!</p> <p>Lubricate the o-ring with grease.</p>	<p>For art. no. see: Required equipment on page 297.</p>  <p>xx0200000221</p>
3	<p>Release the brakes of the axis 6 motor manually.</p>	<p>See section</p> <ul style="list-style-type: none"> • Manually releasing the brakes on page 61
4	<p>Check that the <i>pinion</i> is undamaged on the axis 6 motor.</p>	
5	<p>Carefully insert the <i>axis 6 gearbox</i> into the tilthouse, using guide pins.</p> <p>Make sure the gears of the gearbox mate with the pinion of the axis 6 motor.</p> <p> CAUTION</p> <p>Do not damage pinion or gears in the process!</p>	
6	<p>Secure the gearbox with its <i>attachment screws</i> and <i>washers</i>.</p> <p>Reused screws may be used, providing they are lubricated as detailed in section Screw joints on page 342 before fitting.</p>	<p>8 pcs or 18 pcs (depending on wrist version): M8 x 40, 12.9 quality Gleitmo, Tightening torque: 30 Nm.</p>
7	<p>Refit the <i>turning disk</i>.</p>	<p>See section</p> <ul style="list-style-type: none"> • Replacing the turning disk on page 170
8	<p>Perform a <i>leak-down test</i>.</p>	<p>See section</p> <ul style="list-style-type: none"> • See section Performing a leak-down test on page 140.
9	<p>Refill the gearbox with <i>oil</i>.</p>	<p>See section</p> <ul style="list-style-type: none"> • Changing oil, gearbox axis 6 on page 128

Continues on next page

4 Repair

4.7.3 Replacing gearbox axis 6

Continued

	Action	Note
10	Re-calibrate the robot.	Axis Calibration is described in Calibrating with Axis Calibration method on page 314 . General calibration information is included in section Calibration on page 303 .
11	 DANGER Make sure all safety requirements are met when performing the first test run.	

5 Calibration

5.1 Introduction to calibration

5.1.1 Introduction and calibration terminology

Calibration information

This chapter includes general information about the recommended calibration methods and also the detailed procedures for updating the revolution counters, checking the calibration position etc.

Detailed instructions of how to perform Axis Calibration are given on the FlexPendant during the calibration procedure. To prepare calibration with Axis Calibration method, see [Calibrating with Axis Calibration method on page 314](#).

Calibration terminology

Term	Definition
Calibration method	A collective term for several methods that might be available for calibrating the ABB robot. Each method contains calibration routines.
Synchronization position	Known position of the complete robot where the angle of each axis can be checked against visual synchronization marks.
Calibration position	Known position of the complete robot that is used for calibration of the robot.
Standard calibration	A generic term for all calibration methods that aim to move the robot to calibration position.
Fine calibration	A calibration routine that generates a new zero position of the robot.
Reference calibration	<p>A calibration routine that in the first step generates a reference to current zero position of the robot. The same calibration routine can later on be used to recalibrate the robot back to the same position as when the reference was stored.</p> <p>This routine is more flexible compared to fine calibration and is used when tools and process equipment are installed.</p> <p>Requires that a reference is created before being used for recalibrating the robot.</p> <p>Requires that the robot is dressed with the same tools and process equipment during calibration as during creation of the reference values.</p>
Update revolution counter	A calibration routine to make a rough calibration of each manipulator axis.
Synchronization mark	Visual marks on the robot axes. When marks are aligned, the robot is in synchronization position.

5 Calibration

5.1.2 Calibration methods

5.1.2 Calibration methods

Overview

This section specifies the different types of calibration and the calibration methods that are supplied by ABB.

Types of calibration

Type of calibration	Description	Calibration method
Standard calibration	The calibrated robot is positioned at calibration position. Standard calibration data is found on the SMB (serial measurement board) or EIB in the robot. For robots with RobotWare 5.04 or older, the calibration data is delivered in a file, <code>calib.cfg</code> , supplied with the robot at delivery. The file identifies the correct resolver/motor position corresponding to the robot home position.	Axis Calibration

Brief description of calibration methods

Axis Calibration method

Axis Calibration is a standard calibration method for calibration of IRB 660. It is the recommended method in order to achieve proper performance.

The following routines are available for the Axis Calibration method:

- Fine calibration
- Update revolution counters
- Reference calibration

The calibration equipment for Axis Calibration is delivered as a toolkit.

An introduction to the calibration method is given in this manual, see [Calibrating with Axis Calibration method on page 314](#).

The actual instructions of how to perform the calibration procedure and what to do at each step is given on the FlexPendant. You will be guided through the calibration procedure, step by step.

References

Article numbers for the calibration tools are listed in the section [Special tools on page 347](#).

5.1.3 When to calibrate

When to calibrate

The system must be calibrated if any of the following situations occur.

The resolver values are changed

If resolver values are changed, the robot must be re-calibrated using the calibration methods supplied by ABB. Calibrate the robot carefully with standard calibration, according to information in this manual.

The resolver values will change when parts affecting the calibration position are replaced on the robot, for example motors or parts of the transmission.

The revolution counter memory is lost

If the revolution counter memory is lost, the counters must be updated. See [Updating revolution counters on page 308](#). This will occur when:

- The battery is discharged
- A resolver error occurs
- The signal between a resolver and measurement board is interrupted
- A robot axis is moved with the control system disconnected

The revolution counters must also be updated after the robot and controller are connected at the first installation.

The robot is rebuilt

If the robot is rebuilt, for example, after a crash or when the reachability of a robot is changed, it needs to be re-calibrated for new resolver values.

5 Calibration

5.2.1 Synchronization marks and synchronization position for axes

5.2 Synchronization marks and axis movement directions

5.2.1 Synchronization marks and synchronization position for axes

Introduction

This section shows the position of the synchronization marks and the synchronization position for each axis.

Synchronization marks, IRB 660

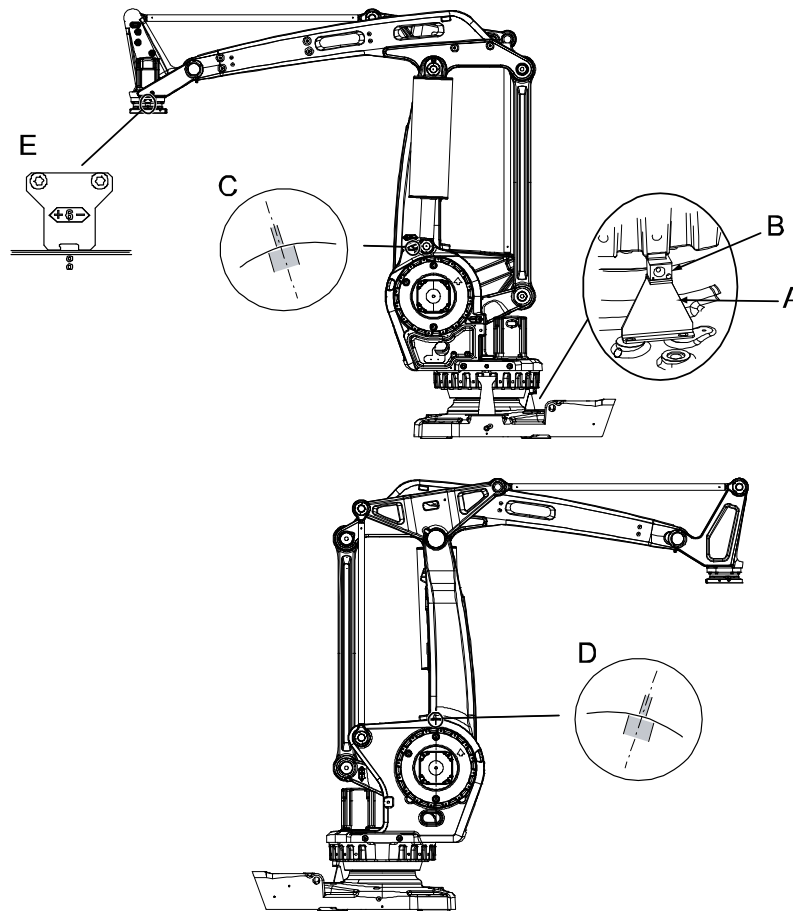

xx0500002487

A	Synchronization plate, axis 1
B	Synchronization tab on robot
C	Synchronization mark, axis 2
D	Synchronization mark, axis 3
E	Synchronization plate and mark, axis 6

Synchronization marks at axes 2 and 3

The synchronization marks at axes 2, 3 and 6, shown in the figure above, consist of two single marks that should be positioned opposite to one another when the robot is standing in its synchronization position. One of the marks is more narrow than the other and should be positioned within the limits of the wider mark.

5.2.2 Calibration movement directions for all axes

Overview

When calibrating, the axis must consistently be run towards the calibration position in the same direction in order to avoid position errors caused by backlash in gears and so on. Positive directions are shown in the graphic below.

Calibration service routines will handle the calibration movements automatically and these might be different from the positive directions shown below.

Manual movement directions, 4 axes

Note! The graphic shows an IRB 260. The positive direction is the same for all 4-axis robots

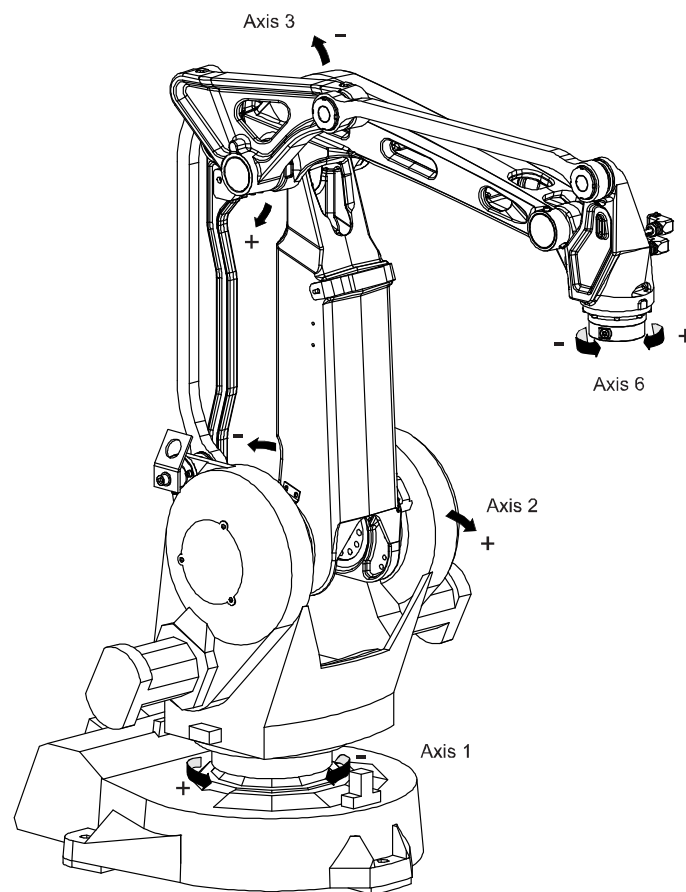

xx0500001927

5 Calibration

5.3.1 Updating revolution counters on IRC5 robots

5.3 Updating revolution counters

5.3.1 Updating revolution counters on IRC5 robots

Introduction

This section describes how to do a rough calibration of each manipulator axis by updating the revolution counter for each axis, using the FlexPendant.

Step 1 - Manually running the manipulator to the synchronization position

Use this procedure to manually run the manipulator to the synchronization position.

	Action	Note
1	Select axis-by-axis motion mode.	
2	Jog the manipulator to align the synchronization marks.	See Synchronization marks and synchronization position for axes on page 306 .
3	When all axes are positioned, update the revolution counter.	Step 2 - Updating the revolution counter with the FlexPendant on page 309 .

Correct calibration position of axis 4 and 6

When jogging the manipulator to synchronization position, it is extremely important to make sure that axes 4 and 6 of the following mentioned manipulators are positioned correctly. The axes can be calibrated at the wrong turn, resulting in an incorrect manipulator calibration.

Make sure the axes are positioned according to the correct calibration values, not only according to the synchronization marks. The correct values are found on a label, located either on the lower arm, underneath the flange plate on the base or on the frame.

At delivery the manipulator is in the correct position. Do NOT rotate axis 4 or 6 at power up before the revolution counters are updated.

If one of the following mentioned axes are rotated one or more turns from its calibration position before updating the revolution counter, the correct calibration position will be lost due to non-integer gear ratio. This affects the following manipulators:

Manipulator variant	Axis 4	Axis 6
IRB 660	-	No

If the synchronization marks seem to be wrong (even if the motor calibration data is correct), try to rotate the axis one turn, update the revolution counter and check the synchronization marks again (try both directions, if needed).

Continues on next page

Step 2 - Updating the revolution counter with the FlexPendant

Use this procedure to update the revolution counter with the FlexPendant (IRC5).

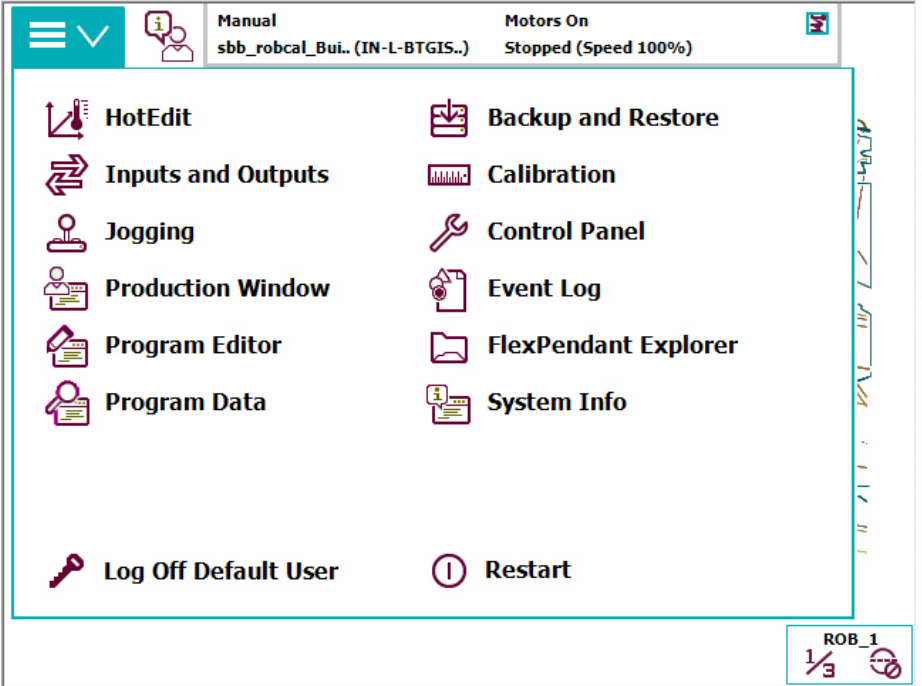
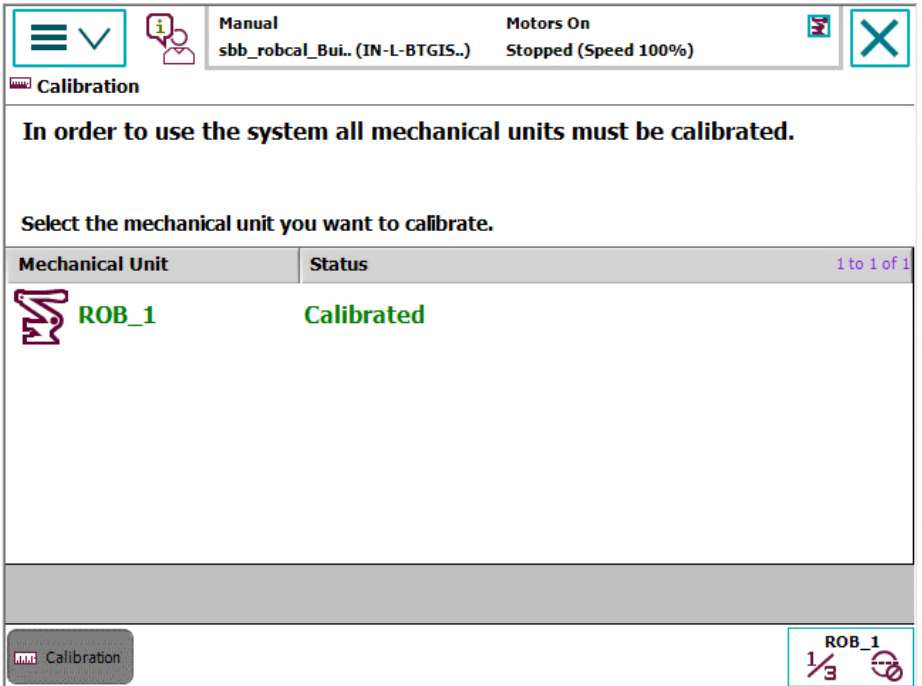
Action	
1	<p>On the ABB menu, tap Calibration.</p>  <p>xx150000942</p>
2	<p>All mechanical units connected to the system are shown with their calibration status. Tap the mechanical unit in question.</p>  <p>xx150000943</p>

Continues on next page

5 Calibration

5.3.1 Updating revolution counters on IRC5 robots

Continued

Action

3 This step is valid for RobotWare 6.02 and later.
 Calibration method used at factory for each axis is shown, as well as calibration method used during last field calibration.
 Tap **Manual Method (Advanced)**.

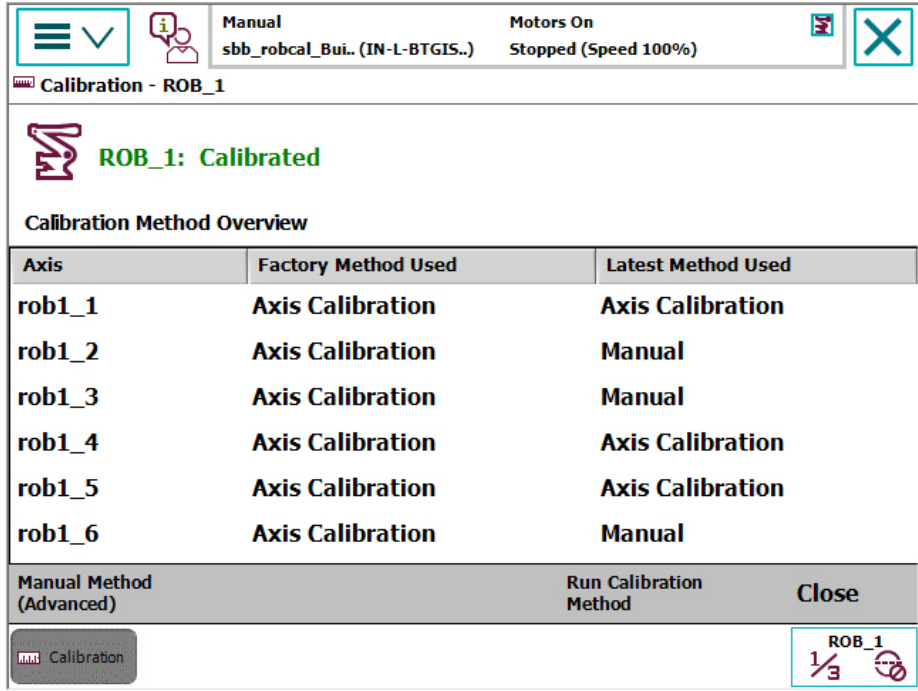

xx1500000944

4 A screen is displayed, tap **Rev. Counters**.

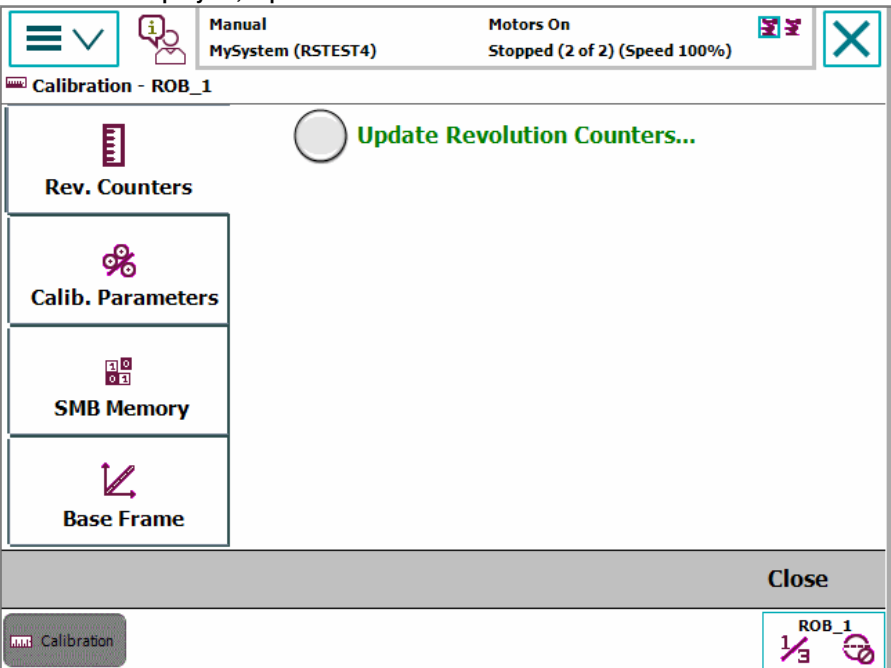

en0400000771

Axis	Factory Method Used	Latest Method Used
rob1_1	Axis Calibration	Axis Calibration
rob1_2	Axis Calibration	Manual
rob1_3	Axis Calibration	Manual
rob1_4	Axis Calibration	Axis Calibration
rob1_5	Axis Calibration	Axis Calibration
rob1_6	Axis Calibration	Manual

Continues on next page

	Action
5	<p>Tap Update Revolution Counters...</p> <p>A dialog box is displayed, warning that updating the revolution counters may change programmed robot positions:</p> <ul style="list-style-type: none"> • Tap Yes to update the revolution counters. • Tap No to cancel updating the revolution counters. <p>Tapping Yes displays the axis selection window.</p>
6	<p>Select the axis to have its revolution counter updated by:</p> <ul style="list-style-type: none"> • Ticking in the box to the left • Tapping Select all to update all axes. <p>Then tap Update.</p>
7	<p>A dialog box is displayed, warning that the updating operation cannot be undone:</p> <ul style="list-style-type: none"> • Tap Update to proceed with updating the revolution counters. • Tap Cancel to cancel updating the revolution counters. <p>Tapping Update updates the selected revolution counters and removes the tick from the list of axes.</p>
8	<p> CAUTION</p> <p>If a revolution counter is incorrectly updated, it will cause incorrect manipulator positioning, which in turn may cause damage or injury!</p> <p>Check the synchronization position very carefully after each update. See Checking the synchronization position on page 328.</p>

5 Calibration

5.3.2 Updating revolution counters on OmniCore robots

5.3.2 Updating revolution counters on OmniCore robots

Introduction

This section describes how to do a rough calibration of each manipulator axis by updating the revolution counter for each axis, using the FlexPendant.



Step 1 - Manually running the manipulator to the synchronization position

Use this procedure to manually run the manipulator to the synchronization position.

	Action	Note
1	Select axis-by-axis motion mode.	
2	Jog the manipulator to align the synchronization marks.	See Synchronization marks and synchronization position for axes on page 306 .
3	When all axes are positioned, update the revolution counter.	Step 2 - Updating the revolution counter with the FlexPendant on page 312 .

Step 2 - Updating the revolution counter with the FlexPendant

Use this procedure to update the revolution counter with the FlexPendant (OmniCore).

	Action
1	On the start screen, tap Calibrate .
2	Select Calibration from the menu. The Mechanical Units page displays a list of available mechanical units.  Note This step is required only if you are not already in the Mechanical Unit page when you open Calibrate .  Note The Mechanical Unit page is displayed only if there are more than one mechanical unit available. Otherwise, the calibration summary page for the available mechanical unit is displayed.
3	Select the mechanical unit for which revolution counter need to be updated.
4	The calibration summary page for the selected mechanical unit is displayed. Calibration method used at factory for each axis is shown, as well as calibration method used during last field calibration.
5	Tap Calibration Methods on the right pane. The calibration options are displayed.
6	Tap Revolution Counters .
7	In the Selection column select the axes for which revolution counters need to be updated.
8	Tap Update . A dialog box is displayed, warning that the updating operation cannot be undone: <ul style="list-style-type: none">• Tap Update to proceed with updating the revolution counters.• Tap Cancel to cancel updating the revolution counters. Tapping Update and a confirmation window is displayed.

Continues on next page

Action	
9	Tap OK. The revolution counter for the selected axes is updated.
10	 CAUTION If a revolution counter is incorrectly updated, it will cause incorrect manipulator positioning, which in turn may cause damage or injury! Check the synchronization position very carefully after each update. See Checking the synchronization position on page 328 .

5 Calibration

5.4.1 Description of Axis Calibration

5.4 Calibrating with Axis Calibration method

5.4.1 Description of Axis Calibration

Instructions for Axis Calibration procedure given on the FlexPendant

The actual instructions of how to perform the calibration procedure and what to do at each step is given on the FlexPendant. You will be guided through the calibration procedure, step by step.

This manual contains a brief description of the method, additional information to the information given on the FlexPendant, article number for the tools and images of where to fit the calibration tools on the robot.

Overview of the Axis Calibration procedure

The Axis Calibration procedure applies to all axes, and is performed on one axis at the time. The robot axes are both manually and automatically moved into position, as instructed on the FlexPendant.

A fixed calibration pin/bushing is installed on each robot axis at delivery.

The Axis Calibration procedure described roughly:

- 1 A removable calibration tool is inserted by the operator into a calibration bushing on the axis chosen for calibration, according to instructions on the FlexPendant.



WARNING

Calibrating the robot with Axis Calibration requires special calibration tools from ABB. Using other pins in the calibration bushings may cause severe damage to the robot and/or personnel.



WARNING

The calibration tool must be fully inserted into the calibration bushing, until the steel spring ring snaps into place.

- 2 During the calibration procedure, RobotWare moves the robot axis chosen for calibration so that the calibration tools get into contact. RobotWare records values of the axis position and repeats the coming-in-contact procedure several times to get an exact value of the axis position.



WARNING

Risk of pinching! The contact force for large robots can be up to 150 kg. Keep a safe distance to the robot.

- 3 The axis position is stored in RobotWare with an active choice from the operator.

Continues on next page

Routines in the calibration procedure

The following routines are available in the Axis Calibration procedure, given at the beginning of the procedure on the FlexPendant.

Fine calibration routine

Choose this routine to calibrate the robot when there are no tools, process cabling or equipment fitted to the robot.

Reference calibration routine

Choose this routine to create reference values and to calibrate the robot when the robot is dressed with tools, process cabling or other equipment.



Note

When calibrating the robot with the reference calibration routine, the robot must be dressed with the same tools, process cabling and any other equipment as when the reference values were created.

If calibrating the robot with reference calibration there must be reference values created before repair is made to the robot, if values are not already available. Creating new values requires possibility to move the robot. The reference values contain positions of all axes, torque of axes and technical data about the tool installed. A benefit with reference calibration is that the current state of the robot is stored and not the state when the robot left the ABB factory. The reference value will be named according to tool name, date etc.

Follow the instructions given in the reference calibration routine on the FlexPendant to create reference values.

When reference calibration is performed, the robot is restored to the status given by the reference values.

Update revolution counters

Choose this routine to make a rough calibration of each manipulator axis by updating the revolution counter for each axis, using the FlexPendant.

Validation

In the mentioned routines, it is also possible to validate the calibration data.

Position of robot axes

The robot axes should be positioned close to 0 degrees before commencing the calibration program. The axis chosen for calibration is then automatically run by the calibration program to its exact calibration position during the calibration procedure.

It is possible to position some of the other axes in positions different from 0 degrees. Information about which axes are allowed to be jogged is given on the FlexPendant.

Continues on next page

5 Calibration

5.4.1 Description of Axis Calibration

Continued

These axes are marked with **Unrestricted** in the FlexPendant window. Also the following table shows the dependencies between the axes.

Requirements for axis positioning during calibration

Required position of axis	Axis to calibrate					
	Axis 1	Axis 2	Axis 3	Axis 4	Axis 5	Axis 6
Axis 1	-	*	*			*
Axis 2	0	-	0			*
Axis 3	0	0	-			*
Axis 6	*	*	*			-

-	Axis to be calibrated
*	Unrestricted. Axis is allowed to be jogged to other position than 0 degrees.
0	Axis must be put in position 0 degrees.

System containing SafeMove

SafeMove will lose its synchronization to the controller if a new calibration is done. New calibration values have to be downloaded to SafeMove, and a new SafeMove calibration has to be done. Make sure that the user rights admit to change the safety settings and to synchronize SafeMove.

For robots with EPS, the same applies as for SafeMove.

5.4.2 Calibration tools for Axis Calibration

Calibration tool set

The calibration tools used for Axis Calibration are designed to meet requirements for calibration performance, durability and safety in case of accidental damage.

The calibration tool will eventually break from fatigue after longer period of use and then needs to be replaced. There is no risk for bad calibrations as long as the calibration tool is in one piece.



WARNING

Calibrating the robot with Axis Calibration requires special calibration tools from ABB. Using other pins in the calibration bushings may cause severe damage to the robot and/or personnel.

Equipment, etc.	Article number	Note
Calibration tool box, Axis Calibration	3HAC055412-001	Delivered as a set of calibration tools. Required if Axis Calibration is the valid calibration method for the robot.

Examining the calibration tool

Check prior to usage

Before using the calibration tool, make sure that the tube insert, the plastic protection and the steel spring ring are present.



WARNING

If any part is missing or damaged, the tool must be replaced immediately.

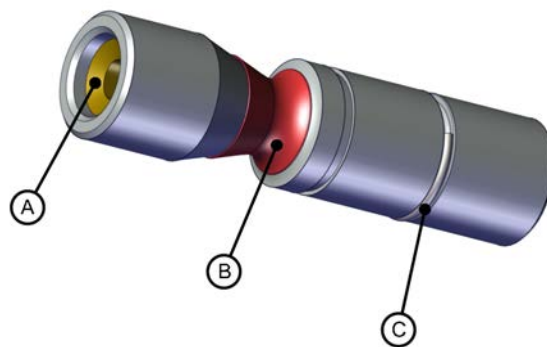

xx1500001914

A	Tube insert
B	Plastic protection
C	Steel spring ring

Continues on next page

5 Calibration

5.4.2 Calibration tools for Axis Calibration

Continued

Periodic check of the calibration tool

If including the calibration tool in a local periodic check system, the following measures should be checked.

- Outer diameter within $\varnothing 12g4$ mm, $\varnothing 8g4$ mm or $\varnothing 6g5$ mm (depending on calibration tool size).
- Straightness within 0.005 mm.

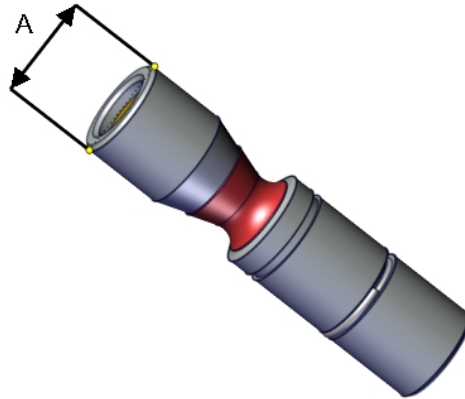

xx150000951

A	Outer diameter
---	----------------

Identifying the calibrating tools

It is possible to make the calibration tool identifiable with, for example, an RFID chip. The procedure of how to install an RFID chip is described below.



Note

The tool identifier is NOT delivered from ABB, it is a customized solution.

	Action	Note
1	<p>It is possible to use any RFID solution, with the correct dimensions. ABB has verified function on some suppliers fulfilling the requirements of NFC compatible devices (13.56 Mhz) according to ISO 14443 or ISO 15693.</p> <div style="margin-top: 10px;"> <p>Note</p> <p>The maximum dimensions on the RFID chip must not exceed $\varnothing 7.9$ mm x 8.0 mm, $\varnothing 5.9$ mm x 8.0 mm or $\varnothing 3.9$ mm x 8.0 mm (depending on calibration tool size).</p> </div>	
2	<p>There is a cavity on one end of the calibration tool in which the RFID chip can be installed.</p> <p>Install the RFID chip according to supplier instructions.</p> <p>Install the chip in flush with the tool end.</p>	

5.4.3 Installation locations for the calibration tools

Location of fixed calibration items

This section shows how the robot is equipped with items for installation of calibration tools for Axis Calibration (fixed calibration pins and/or bushings). Installed calibration tools are not shown.

A fixed calibration pin and a bushing for the movable calibration tool are located on each axis as follows.

If there is not enough space on an axis to install a fixed calibration pin, the axis is equipped with two bushings instead, for installation of two calibration tools when calibration is carried out. This is shown in the figure.

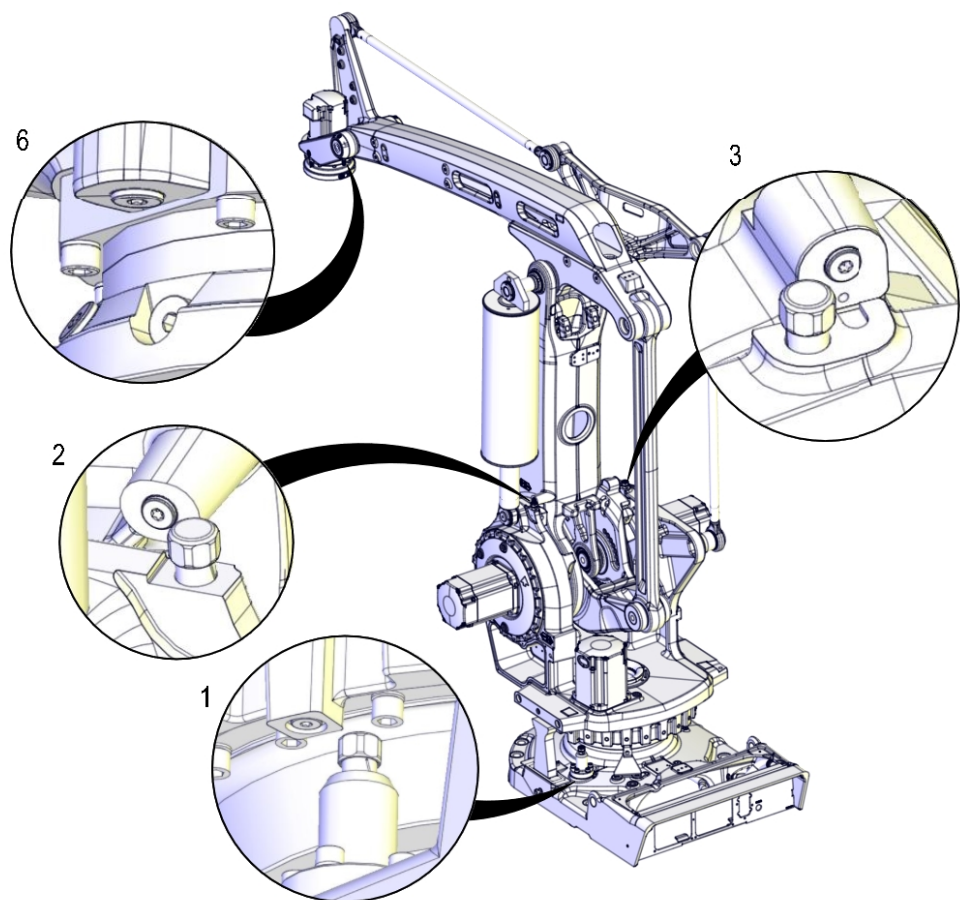

xx160000699

The fixed calibration pin for axis 1 is installed on a removable tower. The tower will need to be removed if electronic position switches are fitted to the robot. Keep the tower in a safe location for future recalibration needs and mark it with robot serial number to ensure that the correct one is refitted.

Continues on next page

5 Calibration

5.4.3 Installation locations for the calibration tools

Continued

Spare parts

When calibration is not being performed, a protective cover and an o-ring should always be installed on the fixed calibration pin as well as a protective plug, included a sealing, in the bushing. Replace damaged parts with new.

Spare part	Article number	Note
Protection cover and plug set	3HAC056806-001	Contains replacement calibration pin covers and protective plugs for the bushing.

5.4.4 Axis Calibration - Running the calibration procedure

Required tools

The calibration tools used for Axis Calibration are designed to meet requirements for calibration performance, durability and safety in case of accidental damage.



WARNING

Calibrating the robot with Axis Calibration requires special calibration tools from ABB. Using other pins in the calibration holes may cause severe damage to the robot and/or personnel.

Equipment, etc.	Article number	Note
Calibration tool box, Axis Calibration	3HAC055412-001	Delivered as a set of calibration tools. Required if Axis Calibration is the valid calibration method for the robot.

Required consumables

Consumable	Article number	Note
Clean cloth	-	

Spare parts

Spare part	Article number	Note
Protection cover and plug set	3HAC056806-001	Contains replacement calibration pin covers and protective plugs for the bushing.

Overview of the calibration procedure on the FlexPendant

The actual instructions of how to perform the calibration procedure and what to do at each step is given on the FlexPendant. You will be guided through the calibration procedure, step by step.

Use the following list to learn about the calibration procedure before running the RobotWare program on the FlexPendant. It gives you a brief overview of the calibration procedure.

After the calibration method has been started on the FlexPendant, the following sequence will be run.

- 1 Choose calibration routine. The routines are described in [Routines in the calibration procedure on page 315](#).
- 2 Choose which axis/axes to calibrate.
- 3 The robot moves to synchronization position.
- 4 Validate the synchronization marks.
- 5 The robot moves to preparation position.
- 6 Remove the protective cover from the fixed pin and the protection plug from the bushing, if any, and install the calibration tool.

Continues on next page

5 Calibration

5.4.4 Axis Calibration - Running the calibration procedure



Continued

- 7 The robot performs a measurement sequence by rotating the axis back and forth.
- 8 Remove the calibration tool and reinstall the protective cover on the fixed pin and the protection plug in the bushing, if any.
- 9 The robot moves to verify that the calibration tool is removed.
- 10 Choose whether to save the calibration data or not.

Calibration of the robot is not finished until the calibration data is saved, as last step of the calibration procedure.

Preparation prior to calibration

The calibration procedure is described in the FlexPendant while conducting it.

	Action	Note
1	 DANGER While conducting the calibration, the robot needs to be connected to power. Make sure that the robot's working area is empty, as the robot can make unpredictable movements.	
2	Wipe the calibration tool clean.  Note The calibration method is exact. Dust, dirt or color flakes will affect the calibration value.	Use a clean cloth.

Starting the calibration procedure

Use this procedure to start the Axis Calibration routine on the FlexPendant.

	Action	Note
1	Tap the calibration icon and enter the calibration main page.	
2	All mechanical units connected to the system are shown with their calibration status. Tap the mechanical unit in question.  Note For RobotWare 7, the mechanical unit page is displayed only if there is more than one mechanical unit available.	
3	The calibration method used at ABB factory for each axis is shown, as well as calibration method used for the robot during last field calibration.	The FlexPendant will give all information needed to proceed with Axis Calibration.
4	Valid for RobotWare 6 Tap Call Calibration Method . The software will automatically call for the procedure for the valid calibration method. If not, tap Call Routine and then tap Axis calibration .	

Continues on next page

5.4.4 Axis Calibration - Running the calibration procedure

Continued

	Action	Note
5	Valid for RobotWare 7 Tap Calibration Methods on the right pane and then tap Calibration . The software will automatically call for the procedure for the valid calibration method.	
6	Follow the instructions given on the FlexPendant.	A brief overview of the sequence that will be run on the FlexPendant is given in Overview of the calibration procedure on the FlexPendant on page 321 .

Restarting an interrupted calibration procedure

If the Axis Calibration procedure is interrupted before the calibration is finished, the RobotWare program needs to be started again. Use this procedure to take required action.

Situation	Action
The three-position enabling device on the FlexPendant has been released during robot movement.	Press and hold the three-position enabling device and press Play .
The RobotWare program is terminated with PP to Main .	Remove the calibration tool, if it is installed, and restart the calibration procedure from the beginning. See Starting the calibration procedure . If the calibration tool is in contact the robot axis needs to be jogged in order to release the calibration tool. Jogging the axis in wrong direction will cause the calibration tool to break. Directions of axis movement is shown in Calibration movement directions for all axes on page 307

Axis Calibration with SafeMove option

To be able to run Axis Calibration, SafeMove needs to be unsynchronized. The Axis Calibration routine recognizes if the robot is equipped with SafeMove and will force SafeMove to unsynchronize automatically.

However, SafeMove may generate other warning messages anytime during the Axis Calibration routine. When a warning message is displayed, tap **Acknowledge** to confirm the unsynchronized state and continue Axis Calibration procedure.



CAUTION

SafeMove must be synchronized after the calibration is completed.

Continues on next page

5 Calibration

5.4.4 Axis Calibration - Running the calibration procedure

Continued

After calibration

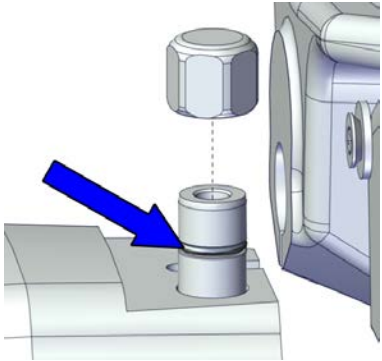
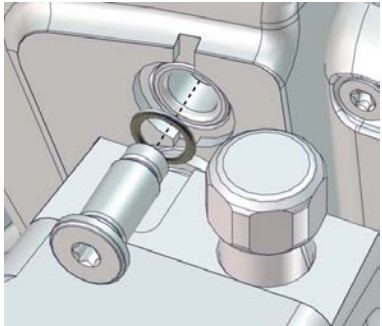
	Action	Note
1	Check the o-ring on the fixed calibration pin. Replace if damaged or missing.	
2	Reinstall the protective cover on the fixed calibration pin on each axis, directly after the axis has been calibrated. Replace the cover with new spare part, if missing or damaged.	 <p data-bbox="1027 725 1139 748">xx1600002102</p> <p data-bbox="1027 763 1362 819">Protection cover and plug set: 3HAC056806-001.</p>
3	Reinstall the protective plug and sealing in the bushing on each axis, directly after the axis has been calibrated. Ensure that the sealing is not damaged. Replace the plug and the sealing with new spare part, if missing or damaged.	 <p data-bbox="1027 1164 1139 1187">xx1500000952</p> <p data-bbox="1027 1202 1362 1258">Protection cover and plug set: 3HAC056806-001.</p>

5.4.5 Reference calibration

Brief introduction to Reference Calibration

Reference calibration is a faster method compared to Fine calibration, as it refers to a previously made calibration.

- 1 Create a backup of the current robot system.
- 2 Check that the active calibration offset values corresponds to the values on the silver label (on the lower arm or the base).
- 3 Jog the manipulator so that all axes are in zero position (ex use `MoveAbsJ` instruction). Check that all axis scales are aligned with calibration marks.
- 4 If the scales differ from calibration marks it might depend on wrong turns of the revolution counters. Make a marker line on the corresponding axis to be able to validate the result of the calibration. If more than one motor revolutions are wrong, the calibration will fail.
- 5 Use a verification position. This is especially recommended if all axes were not aligned with the synchronization marks (step 3). Reuse an existing position that is suitable and accurate so it can be used to validate the repair. Use a position where a deviation in axis calibration gives a big deviation in positioning. Note! Check the position after each repair in one axis.
- 6 Use Reference calibration to save reference values for all axes that is to be replaced. Make sure that the values are saved in RobotStudio or FTP program. The files are located in "Active system folder name/HOME/RefCalibFiles".
- 7 Perform the repair.
- 8 Make sure that the tooling and process equipment are the same as when creating the reference. Use Reference calibration to update the system with new calibration offset value for the repaired axis.
- 9 Check the position against the verification position (step 5).
- 10 Proceed with the repair of the next axis, if necessary, and repeat (step 8-9) for every axis.
- 11 (For system containing SafeMove or EPS) Download new calibration values to SafeMove. Use Visual SafeMove in RobotStudio.(For system containing SafeMove) Download new calibration values to SafeMove. Use Visual SafeMove in RobotStudio.
- 12 (For system containing SafeMove or EPS) Synchronize SafeMove to activate SafeMove.(For system containing SafeMove) Synchronize SafeMove to activate SafeMove.
- 13 Perform test run.
- 14 Update the label for resolver values with new calibration values.

Manual tuning of calibration offset

Manual tuning of calibration offset is normally not needed, but can be useful in some situations. The requirement to do manual tuning is that there is a known accurate position, that worked accurately before the repair (step 5, see [Brief introduction to Reference Calibration on page 325](#)).

Continues on next page

5 Calibration

5.4.5 Reference calibration

Continued

Example "Adjust axis 4":

- 1 Create a backup.
- 2 Run the manipulator to the verification position. (The manipulator position is now deviating from the verification position.)
- 3 Read and note current axis 4 value in degrees (example: 96.3 degrees).
- 4 Manually jog, only axis 4, so that the manipulator is correctly positioned to the verification position.
- 5 Read and note current axis 4 value in degrees (example: 94.2 degrees).
- 6 Move the manipulator to its calibration position.
- 7 Calculate the angle difference (ie $96.3 - 94.2 = 2.1$ degrees).
- 8 Manually jog axis 4 the calculated angle difference (-2.1). NOTE! The direction +/- shall be the same direction as the direction used when axis 4 was manually jogged to coincide with the verification process. In the example -2.1 degrees.
- 9 Make a new manual fine calibration of axis 4 with axis in -2.1 degrees position.
- 10 Check again against the verification position.
- 11 Repeat the manual tuning if needed.
- 12 Create a new reference if the intention is to use the reference in the future.

5.5 Verifying the calibration

Introduction

Always verify the results after calibrating *any* robot axis to verify that all calibration positions are correct.

Verifying the calibration

Use this procedure to verify the calibration result.

	Action	Note
1	Run the calibration home position program twice. Do not change the position of the robot axes after running the program!	See Checking the synchronization position on page 328 .
2	Adjust the <i>synchronization marks</i> when the calibration is done, if necessary.	This is detailed in section Synchronization marks and synchronization position for axes on page 306 .
3	Write down the values on a new label and stick it on top of the calibration label. The label is located on the lower arm.	

5 Calibration

5.6 Checking the synchronization position

5.6 Checking the synchronization position

Introduction

Check the synchronization position of the robot before beginning any programming of the robot system. This may be done:

- Using a `MoveAbsJ` instruction with argument zero on all axes.
- Using the **Jogging** window on the FlexPendant. Using the **Jog** window on the FlexPendant.

Using a `MoveAbsJ` instruction

Use this procedure to create a program that runs all the robot axes to their synchronization position.

	Action	Note
1	On ABB menu tap Program editor .	
2	Create a new program.	
3	Use MoveAbsJ in the Motion&Proc menu.	
4	Create the following program: <pre>MoveAbsJ [[0,0,0,0,0,0], [9E9,9E9,9E9,9E9,9E9,9E9]] \NoEOffs, v1000, fine, tool0</pre>	
5	Run the program in manual mode.	
6	Check that the synchronization marks for the axes align correctly. If they do not, update the revolution counters.	See Synchronization marks and synchronization position for axes on page 306 and Updating revolution counters on page 308 .

Using the jogging window

Use this procedure to jog the robot to the synchronization position of all axes.

	Action	Note
1	On the ABB menu, tap Jogging .	
2	Tap Motion mode to select group of axes to jog.	
3	Tap to select the axis to jog, axis 1, 2, or 3.	
4	Manually run the robots axes to a position where the axis position value read on the FlexPendant, is equal to zero.	
5	Check that the synchronization marks for the axes align correctly. If they do not, update the revolution counters.	See Synchronization marks and synchronization position for axes on page 306 and Updating revolution counters on page 308 .

Continues on next page

Using a MoveAbsJ instruction

Use this procedure to create a program that runs all the robot axes to their synchronization position.

	Action	Note
1	Tap Code .	
2	Create a new program.	
3	Use MoveAbsJ in the Add Instruction menu.	
4	Create the following program: <pre>MoveAbsJ [[0,0,0,0,0,0], [9E9,9E9,9E9,9E9,9E9,9E9]] \NoEOfs, v1000, fine, tool0</pre>	
5	Run the program in manual mode.	
6	Check that the synchronization marks for the axes align correctly. If they do not, update the revolution counters.	See Synchronization marks and synchronization position for axes on page 306 and Updating revolution counters on page 308 .

Using the jogging window

Use this procedure to jog the robot to the synchronization position of all axes.

	Action	Note
1	Tap Jog .	
2	From the Mechanical unit list select a mechanical unit.	
3	From the Motion mode section, select an axis-set that need to be jogged. For example, to jog axis 2, select the axis set Axis 1-3 .	
4	Follow the screen instruction on joystick movements to understand the direction of the axis that you want to move and move the joystick.	
5	Manually run the robots axes to a position where the axis position value read on the FlexPendant, is equal to zero.	
6	Check that the synchronization marks for the axes align correctly. If they do not, update the revolution counters.	See Synchronization marks and synchronization position for axes on page 306 and Updating revolution counters on page 308 .

This page is intentionally left blank

6 Decommissioning

6.1 Introduction to decommissioning

Introduction

This section contains information to consider when taking a product, robot or controller, out of operation.

It deals with how to handle potentially dangerous components and potentially hazardous materials.



Note

The decommissioning process shall be preceded by a risk assessment.

Disposal of materials used in the robot

All used grease/oils and dead batteries **must** be disposed of in accordance with the current legislation of the country in which the robot and the control unit are installed.

If the robot or the control unit is partially or completely disposed of, the various parts **must** be grouped together according to their nature (which is all iron together and all plastic together), and disposed of accordingly. These parts **must** also be disposed of in accordance with the current legislation of the country in which the robot and control unit are installed.

See also [Environmental information on page 332](#).

Transportation

Prepare the robot or parts before transport, this to avoid hazards.

6 Decommissioning

6.2 Environmental information

6.2 Environmental information

Introduction

ABB robots contain components in different materials. During decommissioning, all materials should be dismantled, recycled, or reused responsibly, according to the relevant laws and industrial standards. Robots or parts that can be reused or upcycled helps to reduce the usage of natural resources.

Symbol

The following symbol indicates that the product must not be disposed of as common garbage. Handle each product according to local regulations for the respective content (see table below).

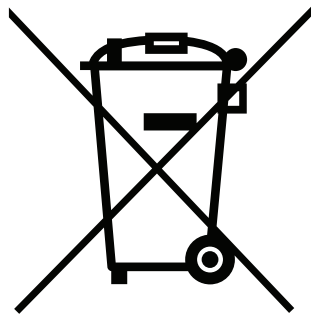

xx1800000058

Materials used in the product

The table specifies some of the materials in the product and their respective use throughout the product.

Dispose components properly according to local regulations to prevent health or environmental hazards.

Material	Example application
Aluminium	Covers, synchronization brackets
Batteries, Lithium	Serial measurement board
Cast iron/nodular iron	Base, lower arm, upper arm
Copper	Cables, motors
Neodymium	Brakes, motors
Oil, grease	Gearboxes
Plastic/rubber	Cables, connectors, drive belts, and so on.
Steel	Gears, screws, base frame, and so on.

Continues on next page

Oil and grease

Where possible, arrange for oil and grease to be recycled. Dispose of via an authorized person/contractor in accordance with local regulations. Do not dispose of oil and grease near lakes, ponds, ditches, down drains, or onto soil. Incineration must be carried out under controlled conditions in accordance with local regulations.

Also note that:

- Spills can form a film on water surfaces causing damage to organisms. Oxygen transfer could also be impaired.
- Spillage can penetrate the soil causing ground water contamination.

6 Decommissioning

6.3 Scrapping of robot

6.3 Scrapping of robot



Note

The decommissioning process shall be preceded by a risk assessment.

Important when scrapping the robot



DANGER

The risk assessment should consider hazards arising in the decommissioning, such as, but not limited to:

- Always remove all batteries. If a battery is exposed to heat, for example from a blow torch, it will explode.
- Always remove all oil/grease in gearboxes. If exposed to heat, for example from a blow torch, the oil/grease will catch fire.
- When motors are removed from the robot, the robot will collapse if it is not properly supported before the motor is removed.
- A used robot does not have the same performance as on delivery. Springs, brakes, bearings, and other parts might be worn or broken.

6.4 Decommissioning of balancing device

General

There is much energy stored in the balancing device. Therefore a special procedure is required to dismantle it. The coil springs inside the balancing device exert a potentially lethal force unless dismantled properly.

The device must be dismantled by a decommissioning company.

Required equipment

Equipment	Art. no.	Note
Standard toolkit	-	Content is defined in section Standard tools on page 346 .
Protective clothing that also covers face and hands	-	Must protect against spatter of sparks and flames.
Cutting torch with a long shaft	-	For opening housing and cutting coils. The long shaft is a safety requirement.
Other tools and procedures may be required. See references to these procedures in the step-by-step instructions below.		These procedures include references to the tools required.



DANGER

Do not under any circumstances, deal with the balancing device in any other way than that detailed in the product documentation! For example, attempting to open the balancing device is potentially lethal!

Action on field, decommissioning

The procedure below details the actions to perform on field, when the balancing device is to be decommissioned.

	Action	Note
1	Remove the balancing device from the robot.	Detailed in section Replacing the balancing device on page 234 .
2	Send the device to a decommissioning company.	Make sure the decommissioning company is well informed about the stored energy built up by high tensioned compression springs and that the device contains some grease and plastic. The following procedure contains useful information about decommissioning.

Continues on next page



6 Decommissioning

6.4 Decommissioning of balancing device

Continued

Decommissioning at decommissioning company, balancing device

The instruction below details how to decommission the balancing device. Contact ABB Robotics for further consultation.

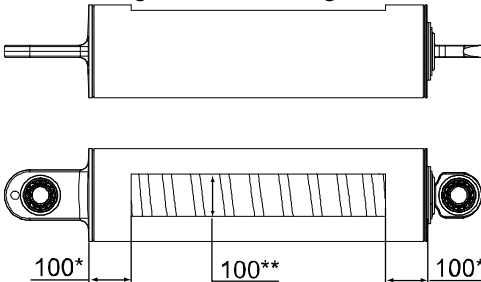
	Action	Note
1	 <p>DANGER</p> <p>There is stored energy built up by high tensioned compression springs inside the balancing device! When a coil is cut the released tension creates a spatter of sparks and flames.</p> <p>The working area must be free of flammable materials. Position the balancing device so that the spatter will be directed away from personnel.</p>	
2	<p>Clamp the device at the working location. Place the device at ground level so that the hole and spring coils are cut from a more safe distance.</p>	
3	 <p>WARNING</p> <p>There is some grease and a plastic layer inside the balancing device. When opening a hole in the device, the cutting torch will cause the plastic and the grease to start to burn.</p> <p>Wear protective clothing! Make sure that the working area is well ventilated!</p>	
4	 <p>DANGER</p> <p>The hole must be cut as specified in the figure. Pieces can be ejected from the cylinder at high speed if the hole is cut larger than specified!</p>	
5	<p>Cut a hole in the housing as shown in the figure.</p>	<p>Use a cutting torch with a long shaft.</p>  <p>xx110000096</p> <p>* Minimum measure, in millimeters. ** Maximum measure, in millimeters.</p>

Continues on next page

	Action	Note
6	 <p>DANGER</p> <p>There is stored energy built up by high tensioned compression springs inside the balancing device! When a coil is cut the released tension creates a spatter of sparks and flames.</p> <p>The working area must be free of flammable materials. Position the balancing device so that the spatter will be directed away from personnel.</p>	
7	<p>Cut at least eight coils of the spring inside the housing.</p>	<p>Use a cutting torch with a long shaft.</p>
8	<p>Double-check the number of coils cut and make sure all the tension in the spring is removed.</p> <p>Cut more coils if there is still tension in the spring.</p>	

This page is intentionally left blank

7 Reference information

7.1 Introduction

General

This chapter includes general information, complementing the more specific information in the different procedures in the manual.

7 Reference information

7.2 Applicable standards

7.2 Applicable standards

General

The product is compliant with ISO 10218-1:2011, *Robots for industrial environments - Safety requirements - Part 1 Robots*, and applicable parts in the normative references, as referred to from ISO 10218-1:2011. In case of deviation from ISO 10218-1:2011, these are listed in the declaration of incorporation. The declaration of incorporation is part of the delivery.

Robot standards

Standard	Description
ISO 9283	Manipulating industrial robots – Performance criteria and related test methods
ISO 9787	Robots and robotic devices – Coordinate systems and motion nomenclatures
ISO 9946	Manipulating industrial robots – Presentation of characteristics

Other standards used in design

Standard	Description
IEC 60204-1	Safety of machinery - Electrical equipment of machines - Part 1: General requirements, normative reference from ISO 10218-1
IEC 61000-6-2	Electromagnetic compatibility (EMC) – Part 6-2: Generic standards – Immunity standard for industrial environments
IEC 61000-6-4	Electromagnetic compatibility (EMC) – Part 6-4: Generic standards – Emission standard for industrial environments
ISO 13849-1:2006	Safety of machinery - Safety related parts of control systems - Part 1: General principles for design, normative reference from ISO 10218-1

Region specific standards and regulations

Standard	Description
ANSI/RIA R15.06	Safety requirements for industrial robots and robot systems
ANSI/UL 1740	Safety standard for robots and robotic equipment
CAN/CSA Z 434-03	Industrial robots and robot Systems - General safety requirements
EN ISO 10218-1	Robots and robotic devices — Safety requirements for industrial robots — Part 1: Robots

7.3 Unit conversion

Converter table

Use the following table to convert units used in this manual.

Quantity	Units		
Length	1 m	3.28 ft.	39.37 in
Weight	1 kg	2.21 lb.	
Weight	1 g	0.035 ounces	
Pressure	1 bar	100 kPa	14.5 psi
Force	1 N	0.225 lbf	
Moment	1 Nm	0.738 lbf-ft	
Volume	1 L	0.264 US gal	

7 Reference information

7.4 Screw joints

7.4 Screw joints

General

This section describes how to tighten the various types of screw joints on ABB robots.

The instructions and torque values are valid for screw joints comprised of metallic materials and do *not* apply to soft or brittle materials.

UNBRAKO screws

UNBRAKO is a special type of screw recommended by ABB for certain screw joints. It features special surface treatment (Gleitmo as described below) and is extremely resistant to fatigue.

Whenever used, this is specified in the instructions, and in such cases, *no other type of replacement screw* is allowed. Using other types of screws will void any warranty and may potentially cause serious damage or injury.

Gleitmo treated screws

Gleitmo is a special surface treatment to reduce the friction when tightening the screw joint. It is recommended by ABB for M6-M20 screw joints. Screws treated with Gleitmo may be reused 3-4 times before the coating disappears. After this the screw must be discarded and replaced with a new one.

When handling screws treated with Gleitmo, protective gloves of nitrile rubber type should be used.

Generally, screws are lubricated with *Gleitmo 603* mixed with *Geomet 500* or *Geomet 702* in proportion 1:3. *Geomet* thickness varies according to screw dimensions, refer to the following.

Dimension	Lubricant	Geomet thickness
M6-M20 (any length except M20x60)	<i>Gleitmo 603 + Geomet 500</i>	3-5 µm
M6-M20 (any length except M20x60)	<i>Gleitmo 603 + Geomet 720</i>	3-5 µm
M20x60	<i>Gleitmo 603 + Geomet 500</i>	8-12 µm
M20x60	<i>Gleitmo 603 + Geomet 720</i>	6-10 µm

Screws lubricated in other ways

Screws lubricated with Molykote 1000 or Molykote P1900 should *only* be used when specified in the repair, maintenance or installation procedure descriptions.

In such cases, proceed as follows:

- 1 Apply lubricant to the screw thread.
- 2 Apply lubricant between the plain washer and screw head.
- 3 Screw dimensions of M8 or larger must be tightened with a torque wrench. Screw dimensions of M6 or smaller may be tightened without a torque wrench *if* this is done by trained and qualified personnel.

Continues on next page

Lubricant	Article number
Molykote 1000 (molybdenum disulphide grease)	3HAC042472-001
Molykote P1900 (molybdenum disulphide grease)	3HAC070875-001

Tightening torque

Before tightening any screw, note the following:

- Determine whether a **standard** tightening torque or **special** torque is to be applied. The **standard torques** are specified in the following tables. Any **special torques** are specified in the repair, maintenance or installation procedure descriptions. **Any special torque specified overrides the standard torque!**
- Use the *correct tightening torque* for each type of screw joint.
- Only use *correctly calibrated* torque keys.
- *Always tighten the joint by hand*, and never use pneumatic tools.
- Use the *correct tightening technique*, that is *do not* jerk. Tighten the screw in a slow, flowing motion.
- Maximum allowed total deviation from the specified value is **10%!**

Tightening torque for oil-lubricated screws with slotted or cross-recess head screws

The following table specifies the recommended standard tightening torque for *oil-lubricated screws with slotted or cross-recess head screws*.



Note

A special torque specified in the repair, maintenance or installation procedure overrides the standard torque.

Tightening torque for oil-lubricated screws with allen head screws

The following table specifies the recommended standard tightening torque for *oil-lubricated screws with allen head screws*.



Note

A special torque specified in the repair, maintenance or installation procedure overrides the standard torque.

Dimension	Tightening torque (Nm)	Tightening torque (Nm)	Tightening torque (Nm)
	Class 8.8, oil-lubricated	Class 10.9, oil-lubricated	Class 12.9, oil-lubricated
M5	6	-	-
M6	10	-	-
M8	24	34	40
M10	47	67	80
M12	82	115	140
M16	200	290	340
M20	400	560	670

Continues on next page

7 Reference information

7.4 Screw joints

Continued

Dimension	Tightening torque (Nm) Class 8.8, oil-lubricated	Tightening torque (Nm) Class 10.9, oil-lubricated	Tightening torque (Nm) Class 12.9, oil-lubricated
M24	680	960	1150

Tightening torque for lubricated screws (Molykote, Gleitmo or equivalent) with allen head screws
The following table specifies the recommended standard tightening torque for *screws lubricated with Molykote 1000, Gleitmo 603 or equivalent with allen head screws.*



Note

A special torque specified in the repair, maintenance or installation procedure overrides the standard torque.

Dimension	Tightening torque (Nm) Class 10.9, lubricated ⁱ	Tightening torque (Nm) Class 12.9, lubricated ⁱ
M5		8
M6		14
M8	28	35
M10	55	70
M12	96	120
M16	235	300
M20	460	550
M24	790	950

ⁱ Lubricated with Molykote 1000, Gleitmo 603 or equivalent

7.5 Weight specifications

Definition

In installation, repair, and maintenance procedures, weights of the components handled are sometimes specified. All components exceeding 22 kg (50 lbs) are highlighted in this way.

To avoid injury, ABB recommends the use of a lifting accessory when handling components with a weight exceeding 22 kg. A wide range of lifting accessories and devices are available for each manipulator model.

Example

Following is an example of a weight specification in a procedure:

Action	Note
 CAUTION The arm weighs 25 kg. All lifting accessories used must be sized accordingly.	

7 Reference information

7.6 Standard tools

7.6 Standard tools

General

All service (repairs, maintenance, and installation) procedures contains lists of tools required to perform the specified activity.

All special tools required are listed directly in the procedures while all the tools that are considered standard are gathered in the standard toolkit and defined in the following table.

This way, the tools required are the sum of the standard toolkit and any tools listed in the instruction.

Contents, standard toolkit

Qty	Tool	Rem.
1	Ring-open-end spanner 8-19 mm	
1	Socket head cap 5-17 mm	
1	Torx socket no: 20-60	
1	Box spanner set	
1	Torque wrench 10-100 Nm	
1	Torque wrench 75-800 Nm	
1	Ratchet head for torque wrench 1/2	
2	Hexagon-headed screw M10x100	
1	Hex bit socket head cap no. 14 socket 40 mm L=100 mm	
1	Hex bit socket head cap no. 14 socket 40 mm L=20 mm	To be shortened to 12 mm
1	Hex bit socket head cap no. 6 socket 40 mm L=145 mm	
1	Hex bit socket head cap no. 6 socket 40mm bit L=220 mm	

7.7 Special tools

General

All service instructions contain lists of tools required to perform the specified activity. The required tools are a sum of standard tools, defined in the section [Standard tools on page 346](#), and of special tools, listed directly in the instructions and also gathered in this section.

Calibration equipment, Axis Calibration

The following table specifies the calibration equipment needed when calibrating the robot with the Axis Calibration method.

Description	Art. no.	Note
Calibration tool box, Axis Calibration	3HAC055412-001	Delivered as a set of calibration tools. Required if Axis Calibration is the valid calibration method for the robot.

Oil exchange equipment

The following table specifies the recommended equipment for oil exchange.

Description	Art. no.	Note
Oil exchange equipment	3HAC021745-001	Includes: <ul style="list-style-type: none"> • Vacuum pump with regulator, hose and coupling • Couplings and adapters • Pump (manual) with hose and coupling • Graduated measuring glass • Oil gun • User instructions.

Basic tools

The following table specifies the tools in the basic toolkit that are used for the current robot model. This toolkit is necessary primarily when removing and refitting the motors.

The tools are also listed directly in the instructions.

Description	Qty	Art. no.
Guide pins M10 x 100	2	3HAC15521-1
Guide pins M10 x 150	2	3HAC15521-2
Lifting tool, motor ax 1	1	3HAC14459-1
Lifting tool, motor ax 2, 3	1	3HAC15534-1
Removal tool, motor M12x		Fits motors axes 1, 2 and 3.
Rotation tool	1	3HAC17105-1
Bits extension	1	3HAC12342-1
Standard toolkit (content described in section Standard tools on page 346)	1	-

Continues on next page

7 Reference information

7.7 Special tools

Continued

Lifting tools

The following table specifies the lifting tools required during several of the service procedures. The tools may be ordered separately and are also specified directly in concerned instructions in the *Product manual, procedures*.

Description	Qty	Article no.
Lifting tool, tilt house		3HAC023154-001
Lifting tool, motor		3HAC15534-1
Lifting tool, frame		3HAC023308-001
Lifting tool, complete robot		3HAC15607-1
Lifting tool, parallel arm		3HAC023098-001
Lifting tool, turning device gearbox ax.1		3HAC14406-1
Lifting tool, base		3HAC14868-1

Special tools

The following table specifies the special tools required during several of the service procedures. The tools may be ordered separately and are also specified directly in concerned instructions.

Description	Qty	Article no.
Lower arm fixture		3HAC7035-1
Pressing, link		3HAC023081-001
Pressing, outer ring on link		3HAC077981-001
KM7 socket		6369901-438
KM8 socket		Standard
KM10 socket		Standard
KM12 socket extended		3HAC023739-001
Pinion crank		3HAC023132-001
Press tool, support ring		3HAC072616-001
Pressing, lower arm/balancing weight		3HAC076749-001
Pressing, upper arm		3HAC023084-001
Pressing, tie rod		3HAC5021-1
Pressing, tilt house		3HAC077982-001
Pressing, outer ring, tilt house		3HAC023075-001
Auxiliary shaft, long		3HAC5275-1
Auxiliary shaft, short		3HAC5276-1
Support shaft/bearing race		3HAC5281-1
Axis 1 pinion		3HAC022436-001
Tool for lubrication		3HAC5222-2
Adapter for shaft axis 3		3HAC071308-001
Guide sleeves		3HAC14446-1

7.8 Lifting accessories and lifting instructions

General

Many repair and maintenance activities require different pieces of lifting accessories, which are specified in each procedure.

The use of each piece of lifting accessories is *not* detailed in the activity procedure, but in the instruction delivered with each piece of lifting accessories.

The instructions delivered with the lifting accessories should be stored for later reference.

This page is intentionally left blank

8 Spare part lists

8.1 Spare part lists and illustrations

Location

Spare parts and exploded views are not included in the manual but delivered as a separate document for registered users on myABB Business Portal, www.abb.com/myABB.



Tip

All documents can be found via myABB Business Portal, www.abb.com/myABB.

This page is intentionally left blank

9 Circuit diagrams

9.1 Circuit diagrams

Overview

The circuit diagrams are not included in this manual, but are available for registered users on myABB Business Portal, www.abb.com/myABB.

See the article numbers in the tables below.

Controllers

Product	Article numbers for circuit diagrams
<i>Circuit diagram - OmniCore V250XT</i>	<i>3HAC074000-008</i>
<i>Circuit diagram - IRC5</i>	<i>3HAC024480-011</i>
<i>Circuit diagram - IRC5 Panel Mounted Controller</i>	<i>3HAC026871-020</i>
<i>Circuit diagram - Euromap 67, design 14</i>	<i>3HAC024120-005</i>
<i>Circuit diagram - Spot welding cabinet</i>	<i>3HAC057185-001</i>

Manipulators

Product	Article numbers for circuit diagrams
<i>Circuit diagram - IRB 120</i>	<i>3HAC031408-003</i>
<i>Circuit diagram - IRB 140 type C</i>	<i>3HAC6816-3</i>
<i>Circuit diagram - IRB 260</i>	<i>3HAC025611-001</i>
<i>Circuit diagram - IRB 360</i>	<i>3HAC028647-009</i>
<i>Circuit diagram - IRB 390</i>	<i>3HAC060545-009</i>
<i>Circuit diagram - IRB 460</i>	<i>3HAC036446-005</i>
<i>Circuit diagram - IRB 660</i>	<i>3HAC025691-001</i>
<i>Circuit diagram - IRB 760</i>	<i>3HAC025691-001</i>
<i>Circuit diagram - IRB 1200</i>	<i>3HAC046307-003</i>
<i>Circuit diagram - IRB 1410</i>	<i>3HAC2800-3</i>
<i>Circuit diagram - IRB 1600/1660</i>	<i>3HAC021351-003</i>
<i>Circuit diagram - IRB 1520</i>	<i>3HAC039498-007</i>
<i>Circuit diagram - IRB 2400</i>	<i>3HAC6670-3</i>
<i>Circuit diagram - IRB 2600</i>	<i>3HAC029570-007</i>
<i>Circuit diagram - IRB 4400/4450S</i>	<i>3HAC9821-1</i>
<i>Circuit diagram - IRB 4600</i>	<i>3HAC029038-003</i>
<i>Circuit diagram - IRB 6620</i>	<i>3HAC025090-001</i>
<i>Circuit diagram - IRB 6620 / IRB 6620LX</i>	<i>3HAC025090-001</i>
<i>Circuit diagram - IRB 6640</i>	<i>3HAC025744-001</i>

Continues on next page

9 Circuit diagrams

9.1 Circuit diagrams

Continued

Product	Article numbers for circuit diagrams
<i>Circuit diagram - IRB 6650S</i>	<i>3HAC13347-1 3HAC025744-001</i>
<i>Circuit diagram - IRB 6660</i>	<i>3HAC025744-001 3HAC029940-001</i>
<i>Circuit diagram - IRB 6700 / IRB 6790</i>	<i>3HAC043446-005</i>
<i>Circuit diagram - IRB 7600</i>	<i>3HAC13347-1 3HAC025744-001</i>
<i>Circuit diagram - IRB 14000</i>	<i>3HAC050778-003</i>
<i>Circuit diagram - IRB 910SC</i>	<i>3HAC056159-002</i>

Index

A

additional mechanical stop location, 114
 allergenic material, 30
 aluminum
 disposal, 332
 ambient humidity
 operation, 44
 storage, 44
 ambient temperature
 operation, 44
 storage, 44
 assembly instructions, 41
 assessment of hazards and risks, 30
 Axis Calibration, 314
 calibration tool
 article number, 317, 321
 examining, 317
 installation position, 319
 overview of method, 314
 procedure on FlexPendant, 321
 protective cover and protection plug, 319, 321

B

balancing device
 inspecting bearing, 103
 inspecting piston rod guide ring, 103
 lubricating bearing, 134
 lubricating piston rod, 134
 base plate
 guide pins, 64
 securing, 64
 batteries
 disposal, 332
 battery
 replacing, 130, 242
 battery pack
 replacing, interval, 94
 battery shutdown
 service routine, 130, 242
 bearing, balancing device, 103
 bearing, balancing device, 134
 brake release, 61
 brake release board, replacement, 245
 brakes
 testing function, 38
 buttons for brake release, 61

C

cabinet lock, 31
 cable harness attachments, 107
 cabling, robot, 84
 cabling between robot and controller, 84
 calibrating
 robot, 314
 roughly, 308, 312
 calibrating robot, 314
 calibration
 rough, 308, 312
 standard type, 304
 verification, 327
 when to calibrate, 305
 calibration manuals, 304
 calibration marks, 306
 calibration position

 jogging to, 328–329
 scales, 306
 calibration scales, 306
 carbon dioxide extinguisher, 31
 cast iron
 disposal, 332
 changing oil
 axis 1, 121
 axis 2, 124
 axis 3, 124
 axis 6, 128
 cleaning, 137
 climbing on robot, 34
 Cold environments, 83
 connecting the robot and controller, cabling, 84
 copper
 disposal, 332

D

damage to additional mechanical stop, 114
 damage to mechanical stop, 112
 dampers, 116
 dimensions
 frame, 73
 turning disk, 74
 upper arm, 72
 direction of axes, 307

E

environmental information, 332
 EPS, 78
 equipment on robot, 72
 ESD
 damage elimination, 49
 sensitive equipment, 49
 expected life, 95
 extended working range, 78
 extended working range, axis 1, 78
 extra equipment
 frame, 73
 robot, 72
 turning disk, 74
 upper arm, 72

F

fire extinguishing, 31
 fitting equipment on robot, 72
 FlexPendant
 jogging to calibration position, 328–329
 MoveAbsJ instruction, 328–329
 updating revolution counters, 309, 312
 fork lift, 50
 foundation
 requirements, 44
 frame
 dimensions, 73

G

gearbox
 oil change axis 1, 121
 oil change axis 2, 124
 oil change axis 3, 124
 oil change axis 6, 128
 gearbox axis 1, replacement, 274
 gearboxes
 location of, 120
 grease, 34

- disposal, 332
- guide pins, base plate, 64
- guide ring, piston rod, 103

H

- hanging
 - installed hanging, 30
- hazard levels, 21
- hazardous material, 332
- height
 - installed at a height, 30
- hot surfaces, 34
- HRA, 30
- humidity
 - operation, 44
 - storage, 44

I

- information labels location, 110
- inspecting
 - additional mechanical stop, 114
 - balancing device bearing, 103
 - balancing device piston rod guide ring, 103
 - cable harness, 107
 - information labels, 110
 - mechanical stop, 112
- inspecting oil levels
 - axes 2-3, 98
 - axis-1, 96
 - axis 6, 101
- inspection
 - dampers, 116
- installation
 - mechanical stop axis 1, 81
- installing equipment on robot, 72
- instructions for assembly, 41
- integrator responsibility, 30
- intervals for maintenance, 93

L

- labels
 - robot, 23
- leak-down test, 140
- lifting accessory, 345
- lifting accessory, robot, 58
- lifting robot
 - with fork lift, 50
 - with lifting accessory, 58
 - with roundslings, 55
- limitation of liability, 19
- linkage
 - replacing upper rod, 198
- Lithium
 - disposal, 332
- loads on foundation, 43
- lock and tag, 31
- lubricants, 34
- lubricating
 - balancing device bearing, 134
 - balancing device piston rod, 134
- lubrication
 - amount in gearboxes, 120
 - type of lubrication, 120

M

- maintenance schedule, 93
- manually releasing brakes, 61

- mechanical stop
 - axis 1, 81
- mechanical stop location, 112
- MoveAbsJ instruction, 328–329

N

- national regulations, 30
- negative directions, axes, 307
- neodymium
 - disposal, 332
- nodular iron
 - disposal, 332

O

- oil, 34
 - amount in gearboxes, 120
 - disposal, 332
 - type of oil, 120
- oil change
 - axis 1, 121
 - axis 2, 124
 - axis 3, 124
 - axis 6, 128
- oil level
 - gearbox axes 2-3, 98
 - gearbox axis-1, 96
 - gearbox axis 6, 101
- operating conditions, 44
- option
 - Extended working range, 78
- original spare parts, 19

P

- pedestal
 - installed on pedestal, 30
- personnel
 - requirements, 20
- piston rod, balancing device, 134
- piston rod guide ring inspection, 103
- plastic
 - disposal, 332
- positive directions, axes, 307
- PPE, 20
- product standards, 340
- protection classes, 45
- protection type, 45
- protective equipment, 20
- protective wear, 20

R

- recycling, 332
- regional regulations, 30
- release brakes, 37
- replacement
 - brake release board, 245
 - gearbox axis 1, 274
 - turning disk, 170
- replacements, report, 139
- replacing
 - upper rod, linkage, 198
 - xx, 87
- report replacements, 139
- requirements on foundation, 44
- responsibility and validity, 19
- restricting
 - working range axis 1, 78, 81
- revolution counters

storing on FlexPendant, 309, 312
 updating, 308, 312

risk of burns, 34
 risk of tipping, 48

robot
 labels, 23
 protection class, 45
 protection types, 45
 symbols, 23

rubber
 disposal, 332

S

safety
 brake testing, 38
 ESD, 49
 fire extinguishing, 31
 release robot axes, 37
 signal lamp, 76
 signals, 21
 signals in manual, 21
 symbols, 21
 symbols on robot, 23
 test run, 89
 safety devices, 31
 safety equipment
 mechanical stop, 81
 signal lamp, 118
 safety hazard
 hydraulic system, 32
 pneumatic system, 32
 safety signals
 in manual, 21
 safety standards, 340
 scales on robot, 306
 schedule for maintenance, 93
 screw joints, 342
 securing
 base plate, 64
 securing, robot, 69
 securing the robot to foundation, attachment screws, 69
 shipping, 331
 signal lamp, 76
 signals
 safety, 21
 SMB
 replacing, 242
 SMB battery
 extension of lifetime, 130, 242
 replacing, 130, 242
 special tools, 347
 speed
 adjusting, 83
 stability, 48
 standards, 340
 ANSI, 340
 CAN, 340
 start of robot in cold environments, 83

steel
 disposal, 332
 storage conditions, 44
 symbols
 safety, 21
 synchronization position, 308, 312
 sync marks, 306
 system integrator requirements, 30

T

temperatures
 operation, 44
 storage, 44
 testing
 brakes, 38
 tools
 Axis Calibration, 347
 for service, 347
 oil exchange equipment, 347
 torques on foundation, 43
 transportation, 331
 troubleshooting
 oil spills, 137
 safety, 39
 turning disk dimensions, 74
 turning disk replacement, 170

U

upcycling, 332
 updating revolution counters, 308, 312
 upper arm
 dimensions, 72
 users
 requirements, 20

V

validity and responsibility, 19
 velocity
 adjusting, 83
 verifying calibration, 327

W

weight, 42
 base plate, 63, 68
 gearbox, 292
 robot, 54–55, 59, 165, 167, 204–205, 210–211, 216–217, 221–224, 230, 232, 237, 239, 252–253, 261, 263, 277, 279, 281, 284, 290
 working range, 46
 restricting axis 1, 81

X

xx
 replacing, 87

Z

zero position
 checking, 328



ABB AB

Robotics & Discrete Automation

S-721 68 VÄSTERÅS, Sweden

Telephone +46 (0) 21 344 400

ABB AS

Robotics & Discrete Automation

Nordlysvegen 7, N-4340 BRYNE, Norway

Box 265, N-4349 BRYNE, Norway

Telephone: +47 22 87 2000

ABB Engineering (Shanghai) Ltd.

Robotics & Discrete Automation

No. 4528 Kangxin Highway

PuDong New District

SHANGHAI 201319, China

Telephone: +86 21 6105 6666

ABB Inc.

Robotics & Discrete Automation

1250 Brown Road

Auburn Hills, MI 48326

USA

Telephone: +1 248 391 9000

abb.com/robotics