

HF series

HF

Indication of Model Numbers

機種型號表示

HF 60		F	O	B	3	P0
減速機機型 Type	型號 Model	入力表示 Input	出力表示 Output	軸承形式 Bearing	速比 Ratio	背隙等級 Backlash Class
HF	60	F : 入力法蘭	O: 出力中空軸	B : 滾珠軸承	單段 1-Stage	P0 ≤ 3
	75	Input Flange	Hollow Output Shaft	Ball Bearing	5, 10, 15	P1 ≤ 6
	100	R44: 減速機 Reducer	N: 單邊免鍵軸套 (有鍵槽)	T: 滾錐軸承	-----	P2 ≤ 9
	140	1-Stage:	Single Clamping (Keyway)	Taper	搭配單段	
	180	R44 · R62...	N1: 單邊免鍵軸套 (無鍵槽)	Bearing	行星減速機	
			Single Clamping (No Keyway)		With 1-Stage	
			M: 雙邊免鍵軸套		Planetary	
			Double Clamping		Reducer	
			S: 單出力軸心 (有鍵槽)		25 ~ 150	
			Single Output Shaft (Keyway)			
			S1: 單出力軸心 (無鍵槽)			
			Single Output Shaft (No Keyway)			

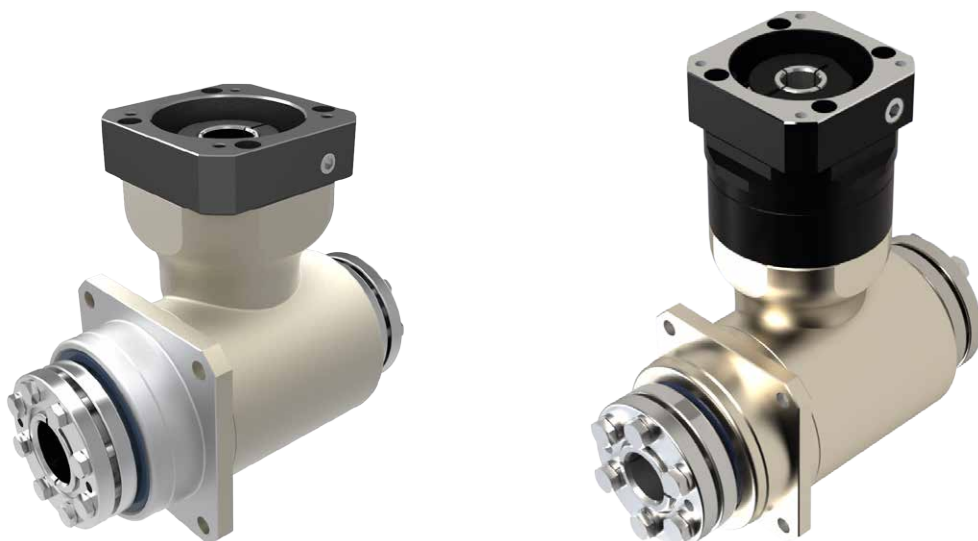

Characteristic of HF Series

HF 系列產品特性

單段減速機 1-Stage

規格 Model No.	代號	單位 Unit	速比 Ratio	60	75	100	140	180
額定輸出扭矩 / Rated Output Torque (Nominal output torque)	T_{2N}	Nm	5	30	35	70	260	720
			10	25	30	60	220	615
			15	20	25	50	180	510
最大加速扭矩 / Max. Acceleration Torque	T_{2B}	Nm	5~15	1.5 倍額定輸出扭矩 1.5 Times of Rated Output Torque				
最大輸出扭矩 / Max. Output Torque 急停扭矩 / Emergency Stop Torque	T_{2NOT}	Nm	5~15	3 倍額定輸出扭矩 3 Times of Rated Output Torque				
額定輸入轉速 / Rated Input Speed	n_{IN}	rpm	5	2,200	2,100	1,800	1,150	700
			10	3,300	3,200	2,700	1,800	1,200
			15	4,000	3,900	3,300	2,300	1,600
最大輸入轉速 / Max. Input Speed	n_{IB}	rpm	5~15	6,000	5,000	4,000	3,000	3,000
背隙 / Backlash	J_t	arcmin	P0	≤ 3	≤ 3	≤ 3	≤ 3	≤ 3
			P1	≤ 6	≤ 6	≤ 6	≤ 6	≤ 6
			P2	≤ 9	≤ 9	≤ 9	≤ 9	≤ 9
容許徑向力 / Max. Radial Force 滾珠軸承 Ball Bearing	F_{2rB}	N	5~15	1,040	1,495	2,366	5,837	7,020
容許軸向力 / Max. Axial Force 滾珠軸承 Ball Bearing	F_{2aB}	N	5~15	520	748	1,183	2,919	3,510
使用壽命 / Service Life	L_H	hr	5~15	S5 周期運轉 : >30,000 (S1 連續運轉 : >15,000 hrs) S5 Cycle Operation: >30,000 (S1 Continuous Operation: >15,000 hrs)				
效 率 / Efficiency	η	%	5~8	≥ 96%				
			10~15	≥ 93%				
使用溫度 / Operating Temperature		°C	5~15	-10°C ~ +90°C				
潤 滑 / Lubrication			5~15	全合成潤滑油 Synthetic Oil				
噪 音 值 / Noise Level		dB	5~15	≤ 66	≤ 66	≤ 66	≤ 68	≤ 70

轉動慣量 Mass Moments of Inertia (kgcm²)

速比 Ratio	60	75	100	140	180
5	0.23	0.23	0.58	4.00	13.53
10	0.15	0.15	0.38	2.46	7.38
15	0.13	0.13	0.34	2.07	5.76

HF-FO series

RATIO : 5.10.15 (單段 1-Stage)

入力法蘭 - 出力中空軸

Input Flange - Hollow Output Shaft

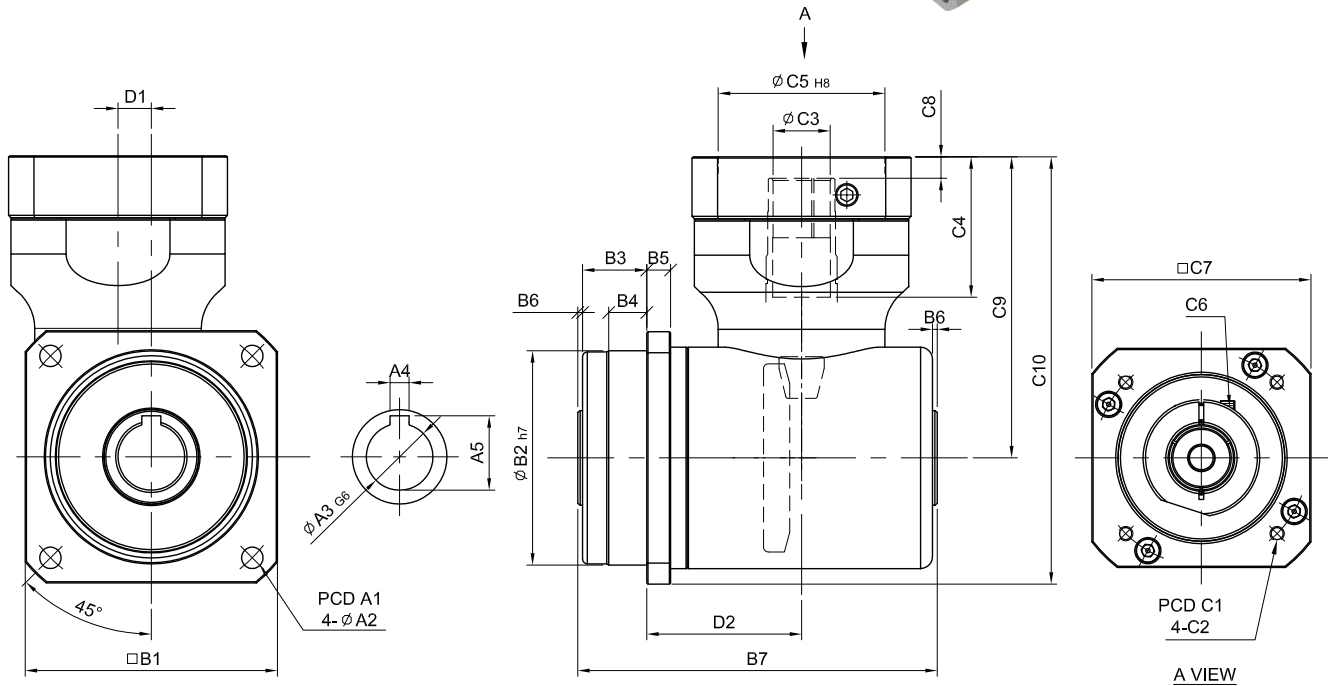

unit: mm

	Model	60	75	100	140	180
	Code					
A	A1	68	85	120	165	215
	A2	5.5	6.5	9	11	13
	A3	15	20	28	40	55
	A4	4	5	8	12	14
	A5	16.7	22.3	31.3	43.3	58.8
B	B1	62	76	106	142	190
	B2	60	70	90	130	160
	B3	18	18	27	27	26
	B4	11	12	16	15.5	15.5
	B5	6	7	10	12	15
	B6	2	2	2	3	3
	B7	103	113	151	193	247
C	C1	46 · 60 · 63	70 · 75 · 90	90 · 100 · 115 · 145	115 · 145 · 165	145 · 165 · 200
	C2	M3 · M4 · M5	M4 · M5 · M6	M5 · M6 · M8	M6 · M8 · M10	M8 · M10 · M12
	C3	11	14	24	35	42
	C4	26	33	59	82	84.5
	C5	30 · 40 · 50	50 · 60 · 70	70 · 80 · 95 · 110	95 · 110 · 130	110 · 130 · 180
	C6	M4 x P0.7	M5 x P0.8	M6 x P1.0	M8 x P1.25	M10 x P1.5
	C7	46 · 55	64 · 70 · 80	92 · 110 · 130	122 · 130 · 150	146 · 150 · 190
	C8	5	6	9	10	10
	C9	69	95.5	126.5	179	228
	C10	100	133.5	179.5	250	323
D	D1	9	9	14	23	32
	D2	41.5	48	65	90	125
Weight ±3% (kg)						

HF-FN series

RATIO : 5.10.15 (單段 1-Stage)



入力法蘭 - 單邊免鍵軸套

Input Flange - Single Clamping

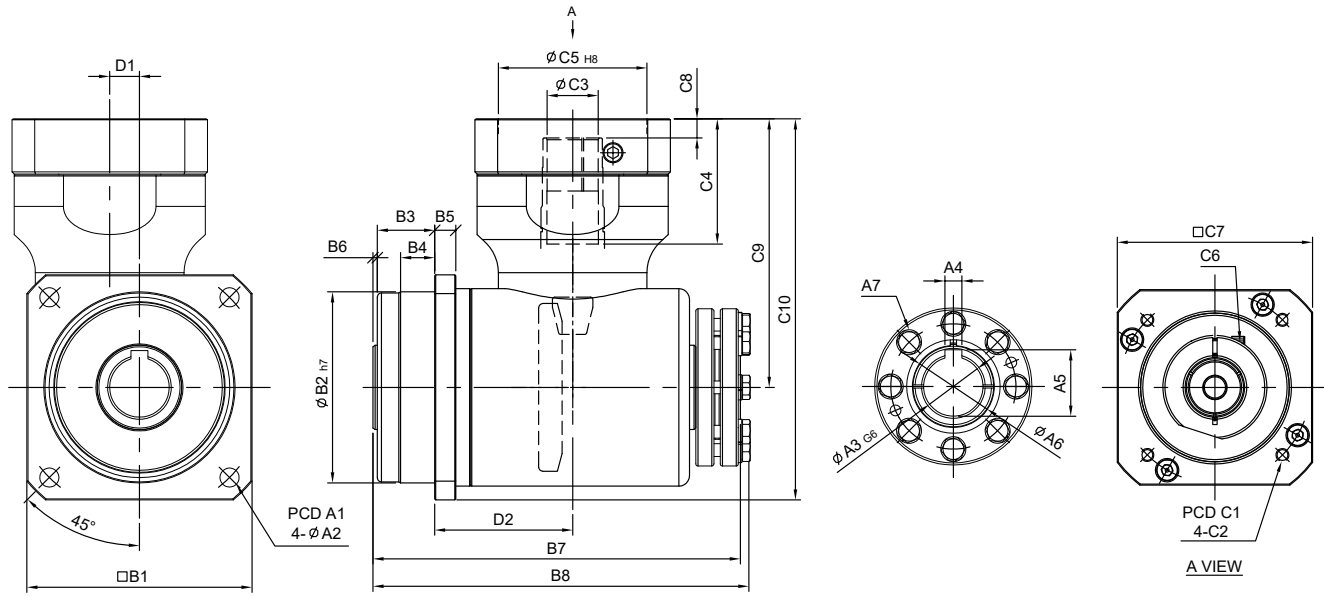

unit: mm

Model Code	60	75	100	140	180	
A	A1	68	85	120	165	215
	A2	5.5	6.5	9	11	13
	A3	15	20	28	40	55
	A4	4	5	8	12	14
	A5	16.7	22.3	31.3	43.3	58.8
	A6	22	28	38	52	73
	A7	6-M6	6-M6	8-M6	8-M8	8-M8
B	B1	62	76	106	142	190
	B2	60	70	90	130	160
	B3	18	18	27	27	26
	B4	11	12	16	15.5	15.5
	B5	6	7	10	12	15
	B6	2	2	2	3	3
	B7	123.5	134	173	223	279
	B8	127	138	177	229	284
C	C1	46 · 60 · 63	70 · 75 · 90	90 · 100 · 115 · 145	115 · 145 · 165	145 · 165 · 200
	C2	M3 · M4 · M5	M4 · M5 · M6	M5 · M6 · M8	M6 · M8 · M10	M8 · M10 · M12
	C3	11	14	24	35	42
	C4	26	33	59	82	84.5
	C5	30 · 40 · 50	50 · 60 · 70	70 · 80 · 95 · 110	95 · 110 · 130	110 · 130 · 180
	C6	M4 x P0.7	M5 x P0.8	M6 x P1.0	M8 x P1.25	M10 x P1.5
	C7	46 · 55	64 · 70 · 80	92 · 110 · 130	122 · 130 · 150	146 · 150 · 190
	C8	5	6	9	10	10
	C9	69	95.5	126.5	179	228
	C10	100	133.5	179.5	250	323
D	D1	9	9	14	23	32
	D2	41.5	48	65	90	125

Weight $\pm 3\%$ (kg)

HF-FM series

RATIO : 5.10.15 (單段 1-Stage)

入力法蘭 - 雙邊免鍵軸套

Input Flange - Double Clamping

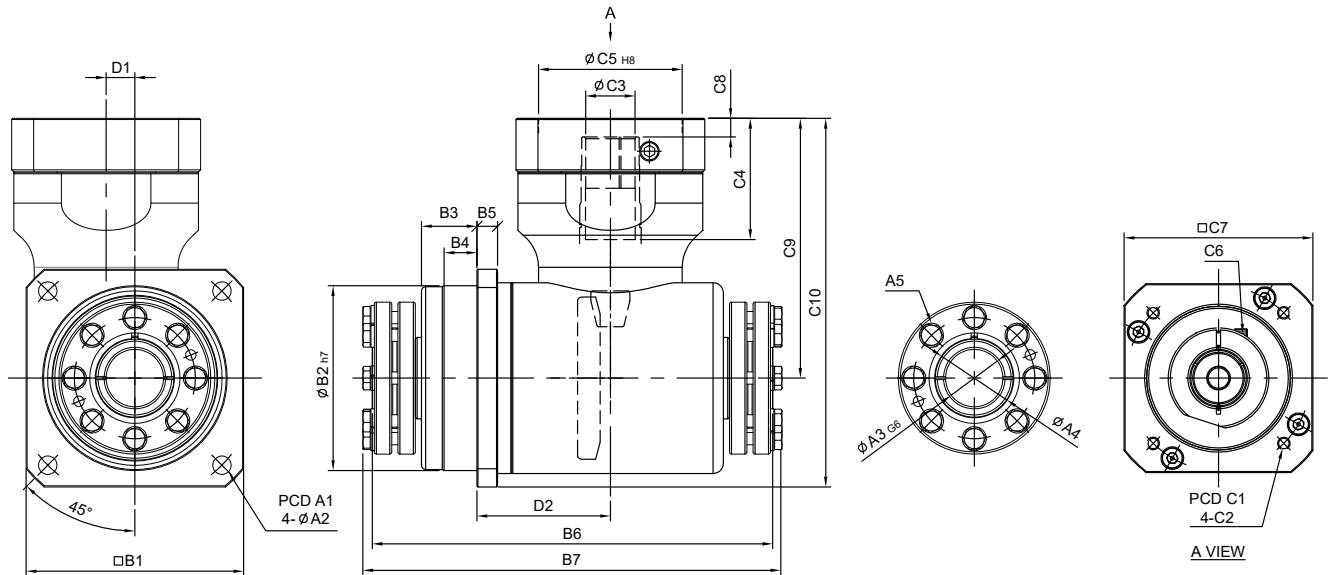

unit: mm

	Model Code	60	75	100	140	180
		A	A1	68	85	120
	A2	5.5	6.5	9	11	13
	A3	15	20	28	40	55
	A4	22	28	38	52	73
	A5	6-M6	6-M6	8-M6	8-M8	8-M8
B	B1	62	76	106	142	190
	B2	60	70	90	130	160
	B3	18	18	27	27	26
	B4	11	12	16	15.5	15.5
	B5	6	7	10	12	15
	B6	144	155	195	253	311
	B7	153	162	202	264	320
C	C1	46 · 60 · 63	70 · 75 · 90	90 · 100 · 115 · 145	115 · 145 · 165	145 · 165 · 200
	C2	M3 · M4 · M5	M4 · M5 · M6	M5 · M6 · M8	M6 · M8 · M10	M8 · M10 · M12
	C3	11	14	24	35	42
	C4	26	33	59	82	84.5
	C5	30 · 40 · 50	50 · 60 · 70	70 · 80 · 95 · 110	95 · 110 · 130	110 · 130 · 180
	C6	M4 x P0.7	M5 x P0.8	M6 x P1.0	M8 x P1.25	M10 x P1.5
	C7	46 · 55	64 · 70 · 80	92 · 110 · 130	122 · 130 · 150	146 · 150 · 190
	C8	5	6	9	10	10
	C9	69	95.5	126.5	179	228
	C10	100	133.5	179.5	250	323
D	D1	9	9	14	23	32
	D2	41.5	48	65	90	125

Weight ±3% (kg)

HF-FS series

RATIO : 5.10.15 (單段 1-Stage)

入力法蘭 - 單出力軸心

Input Flange - Single Output Shaft

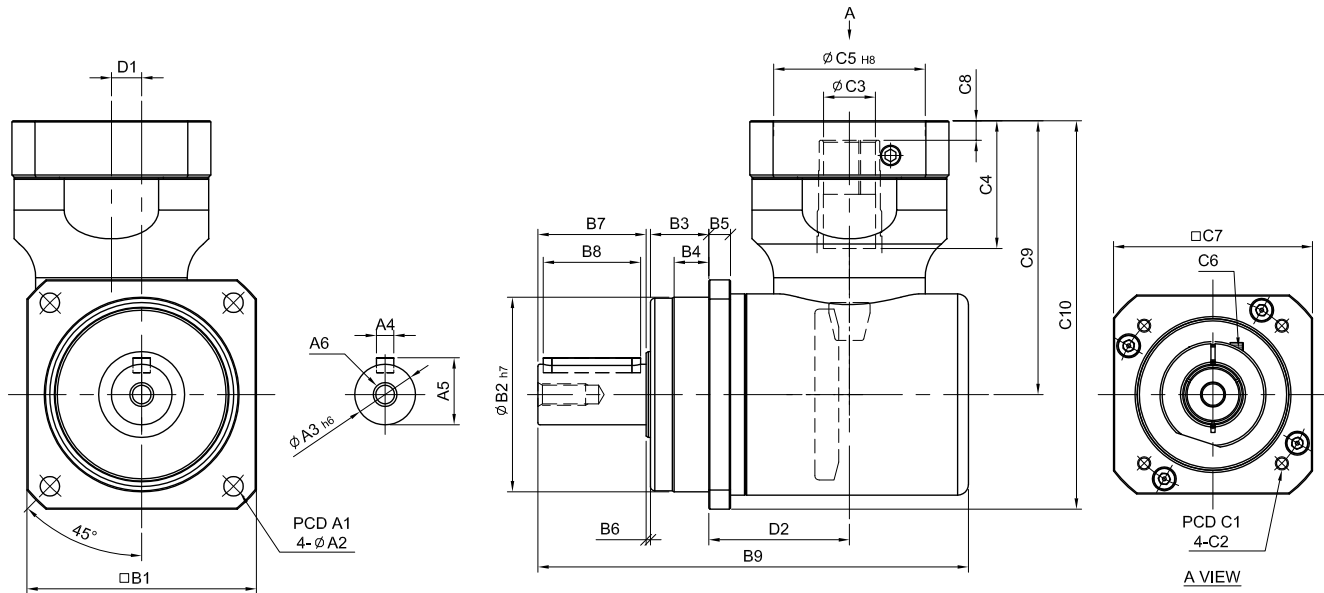

unit: mm

Model Code	60	75	100	140	180	
A	A1	68	85	120	165	215
	A2	5.5	6.5	9	11	13
	A3	16	22	28	40	55
	A4	5	6	8	12	16
	A5	18	24.5	31	43	59
	A6	M5 x P0.8	M8 x P.125	M10 x 1.5	M12 x P1.75	M16 x P20
B	B1	62	76	106	142	190
	B2	60	70	90	130	160
	B3	18	18	27	27	26
	B4	11	12	16	15.5	15.5
	B5	6	7	10	12	15
	B6	2	2	2	3	3
	B7	28	36	50	70	82
	B8	25	32	45	60	70
	B9	129	147	199	260	326
C	C1	46 · 60 · 63	70 · 75 · 90	90 · 100 · 115 · 145	115 · 145 · 165	145 · 165 · 200
	C2	M3 · M4 · M5	M4 · M5 · M6	M5 · M6 · M8	M6 · M8 · M10	M8 · M10 · M12
	C3	11	14	24	35	42
	C4	26	33	59	82	84.5
	C5	30 · 40 · 50	50 · 60 · 70	70 · 80 · 95 · 110	95 · 110 · 130	110 · 130 · 180
	C6	M4 x P0.7	M5 x P0.8	M6 x P1.0	M8 x P1.25	M10 x P1.5
	C7	46 · 55	64 · 70 · 80	92 · 110 · 130	122 · 130 · 150	146 · 150 · 190
	C8	5	6	9	10	10
	C9	69	95.5	126.5	179	228
	C10	100	133.5	179.5	250	323
D	D1	9	9	14	23	32
	D2	41.5	48	65	90	125

Weight ±3% (kg)

HF-RO series

RATIO : 25.50.75.100.150 (雙段 2-Stage)

搭配行星減速機 - 出力中空軸

Fitted with Planetary Reducer - Hollow Output Shaft

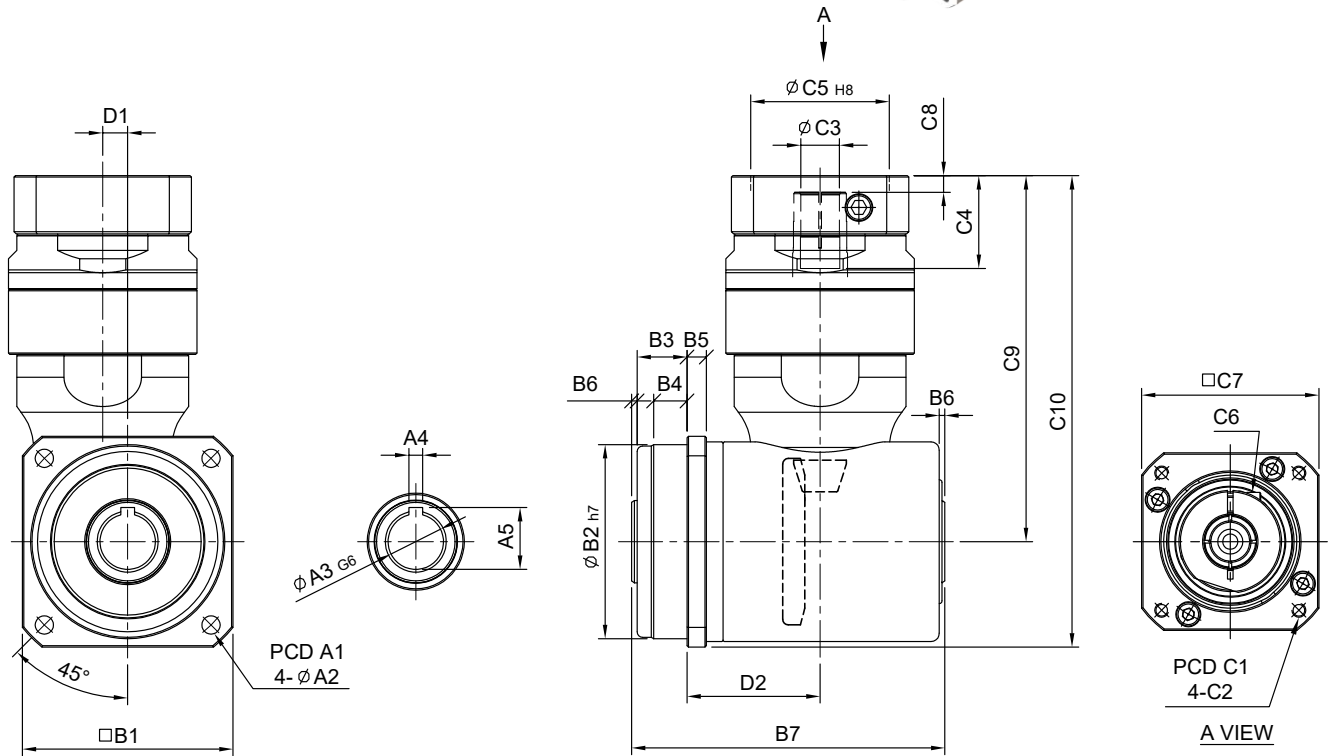

unit: mm

	Model Code	60	75	100	140	180
		A	A1	68	85	120
	A2	5.5	6.5	9	11	13
	A3	15	20	28	40	55
	A4	4	5	8	12	14
	A5	16.7	22.3	31.3	43.3	58.8
B	B1	62	76	106	142	190
	B2	60	70	90	130	160
	B3	18	18	27	27	26
	B4	11	12	16	15.5	15.5
	B5	6	7	10	12	15
	B6	2	2	2	3	3
	B7	103	113	151	193	247
C	C1	46·60·63	70·75·90	70·75·90	90·100·115·145	115·145·165
	C2	M3·M4·M5	M4·M5·M6	M4·M5·M6	M5·M6·M8	M6·M8·M10
	C3	8·9·11	11·14	11·14	16·19·22·24	22·24·28·32
	C4	26	33.5	33.5	59.2	67.5
	C5	30·40·50	50·60·70	50·60·70	70·80·95·110	95·110·130
	C6	M4 x P0.7	M5 x P0.8	M5 x P0.8	M6 x P1.0	M8 x P1.25
	C7	46·55	64·70·80	64·70·80	92·110·130	122·130·150
	C8	5	6	6	9.2	10.5
	C9	98	132	155	220	278.5
	C10	129	170	208	294.5	382.5
D	D1	9	9	14	23	32
	D2	41.5	48	65	90	125
Weight ±3% (kg)						

HF-RN series

RATIO : 25.50.75.100.150 (雙段 2-Stage)

搭配行星減速機 - 單邊免鍵軸套

Fitted with Planetary Reducer - Single Clamping

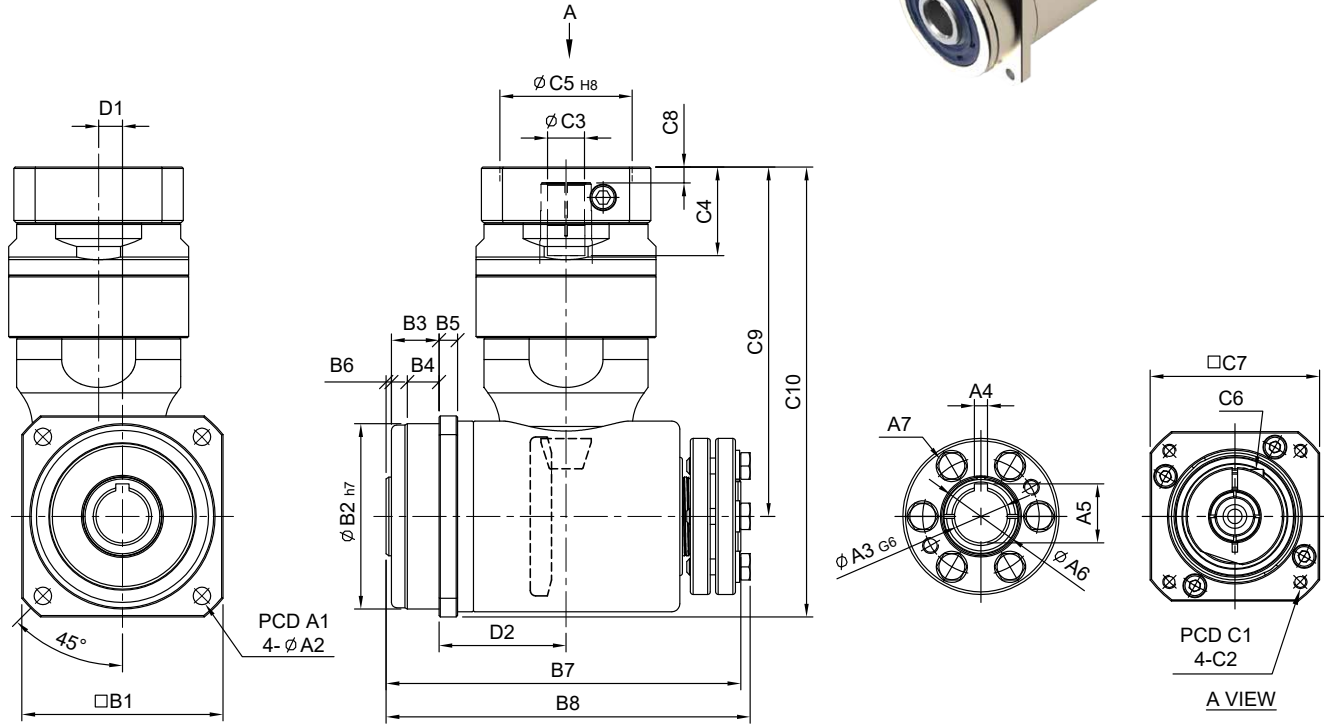

unit: mm

	Model Code	60	75	100	140	180
		A	A1	68	85	120
A2	5.5		6.5	9	11	13
A3	15		20	28	40	55
A4	4		5	8	12	14
A5	16.7		22.3	31.3	43.3	58.8
A6	22		28	38	52	73
A7	6-M6		6-M6	8-M6	8-M6	8-M6
B	B1	62	76	106	142	190
	B2	60	70	90	130	160
	B3	18	18	27	27	26
	B4	11	12	16	15.5	15.5
	B5	6	7	10	12	15
	B6	2	2	2	3	3
	B7	123.5	134	173	223	279
	B8	127	138	177	229	284
C	C1	46 · 60 · 63	70 · 75 · 90	70 · 75 · 90	90 · 100 · 115 · 145	115 · 145 · 165
	C2	M3 · M4 · M5	M4 · M5 · M6	M4 · M5 · M6	M5 · M6 · M8	M6 · M8 · M10
	C3	8 · 9 · 11	11 · 14	11 · 14	16 · 19 · 22 · 24	22 · 24 · 28 · 32
	C4	26	33.5	33.5	59.2	67.5
	C5	30 · 40 · 50	50 · 60 · 70	50 · 60 · 70	70 · 80 · 95 · 110	95 · 110 · 130
	C6	M4 x P0.7	M5 x P0.8	M5 x P0.8	M6 x P1.0	M8 x P1.25
	C7	46 · 55	64 · 70 · 80	64 · 70 · 80	92 · 110 · 130	122 · 130 · 150
	C8	5	6	6	9.2	10.5
	C9	98	132	155	220	278.5
	C10	129	170	208	294.5	382.5
D	D1	9	9	14	23	32
	D2	41.5	48	65	90	125

Weight ±3% (kg)

HF-RM series

RATIO : 25.50.75.100.150 (雙段 2-Stage)

搭配行星減速機 - 雙邊免鍵軸套

Fitted with Planetary Reducer - Double Clamping

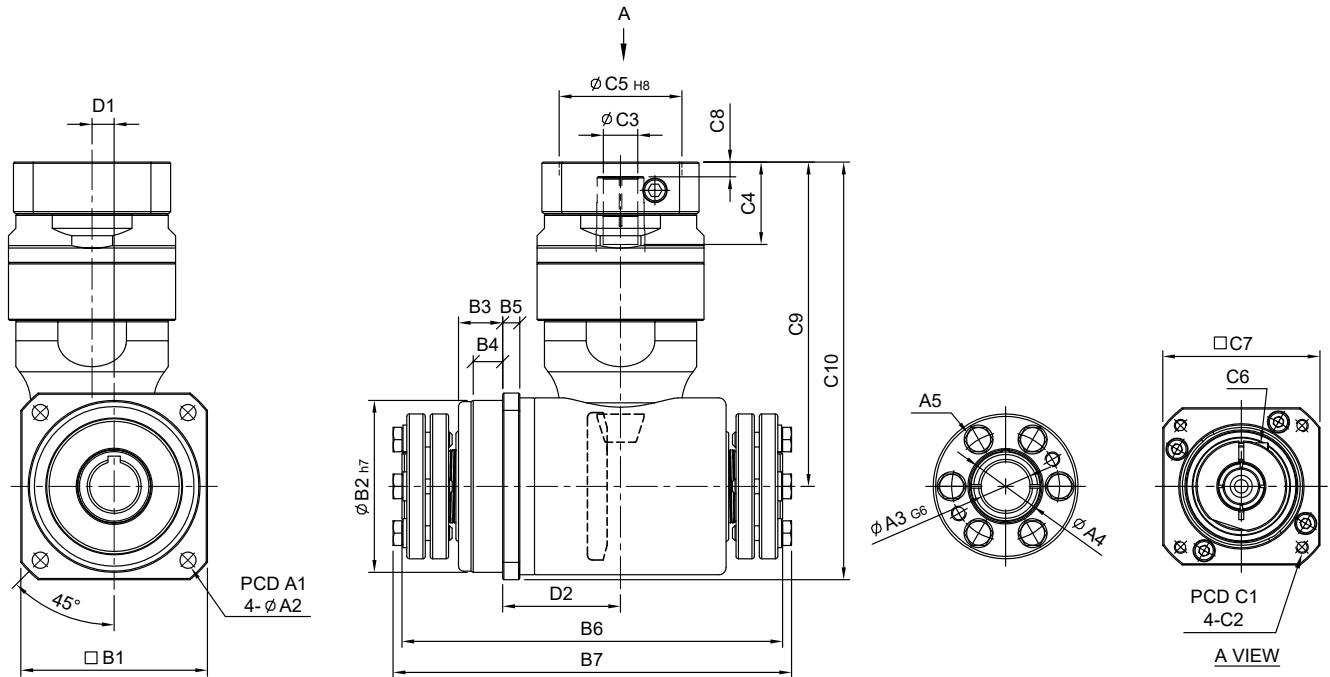

unit: mm

	Model Code	60	75	100	140	180
		A	A1	68	85	120
	A2	5.5	6.5	9	11	13
	A3	15	20	28	40	55
	A4	22	28	38	52	73
	A5	6-M6	6-M6	8-M6	8-M6	8-M6
B	B1	62	76	106	142	190
	B2	60	70	90	130	160
	B3	18	18	27	27	26
	B4	11	12	16	15.5	15.5
	B5	6	7	10	12	15
	B6	144	155	195	253	311
	B7	153	162	202	264	320
C	C1	46·60·63	70·75·90	70·75·90	90·100·115·145	115·145·165
	C2	M3·M4·M5	M4·M5·M6	M4·M5·M6	M5·M6·M8	M6·M8·M10
	C3	8·9·11	11·14	11·14	16·19·22·24	22·24·28·32
	C4	26	33.5	33.5	59.2	67.5
	C5	30·40·50	50·60·70	50·60·70	70·80·95·110	95·110·130
	C6	M4 x P0.7	M5 x P0.8	M5 x P0.8	M6 x P1.0	M8 x P1.25
	C7	46·55	64·70·80	64·70·80	92·110·130	122·130·150
	C8	5	6	6	9.2	10.5
	C9	98	132	155	220	278.5
	C10	129	170	208	294.5	382.5
D	D1	9	9	14	23	32
	D2	41.5	48	65	90	125

Weight ±3% (kg)

HF-RS series

RATIO : 25.50.75.100.150 (雙段 2-Stage)

搭配行星減速機 - 單出力軸心

Fitted with Planetary Reducer - Single Output Shaft

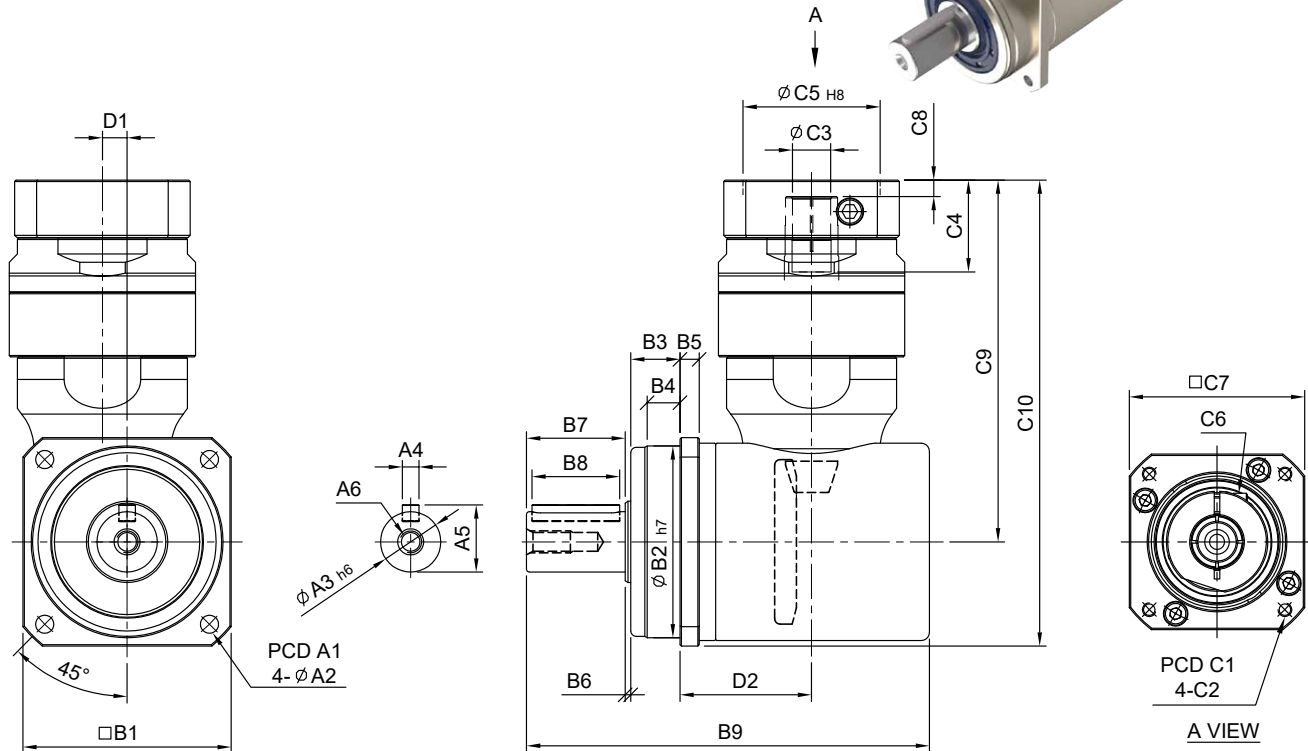

unit: mm

Model Code	60	75	100	140	180	
A	A1	68	85	120	165	215
	A2	5.5	6.5	9	11	13
	A3	16	22	28	40	55
	A4	5	6	8	12	16
	A5	18	24.5	31	43	59
	A6	M5 x P0.8	M8 x P.125	M10 x 1.5	M12 x P1.75	M16 x P20
B	B1	62	76	106	142	190
	B2	60	70	90	130	160
	B3	18	18	27	27	26
	B4	11	12	16	15.5	15.5
	B5	6	7	10	12	15
	B6	2	2	2	3	3
	B7	28	36	50	70	82
	B8	25	32	45	60	70
	B9	129	147	199	260	326
C	C1	46 · 60 · 63	70 · 75 · 90	70 · 75 · 90	90 · 100 · 115 · 145	115 · 145 · 165
	C2	M3 · M4 · M5	M4 · M5 · M6	M4 · M5 · M6	M5 · M6 · M8	M6 · M8 · M10
	C3	8 · 9 · 11	11 · 14	11 · 14	16 · 19 · 22 · 24	22 · 24 · 28 · 32
	C4	26	33.5	33.5	59.2	67.5
	C5	30 · 40 · 50	50 · 60 · 70	50 · 60 · 70	70 · 80 · 95 · 110	95 · 110 · 130
	C6	M4 x P0.7	M5 x P0.8	M5 x P0.8	M6 x P1.0	M8 x P1.25
	C7	46 · 55	64 · 70 · 80	64 · 70 · 80	92 · 110 · 130	122 · 130 · 150
	C8	5	6	6	9.2	10.5
	C9	98	132	155	220	278.5
	C10	129	170	208	294.5	382.5
D	D1	9	9	14	23	32
	D2	41.5	48	65	90	125

Weight ±3% (kg)